

THIS DRAWING IS UNPUBLISHED.

RELEASED FOR PUBLICATION

© COPYRIGHT -

ALL RIGHTS RESERVED.

LOC DIST

REVISIONS

P	LTR	DESCRIPTION	DATE	DWN	APVD
	A	RELEASE TO PRODUCTION	18DEC2014	NV	PS

REFERENCE MATING INTERFACE PATTERN:
1,27 STAGGERED PITCH x 1,5 ROW-DISTANCE.

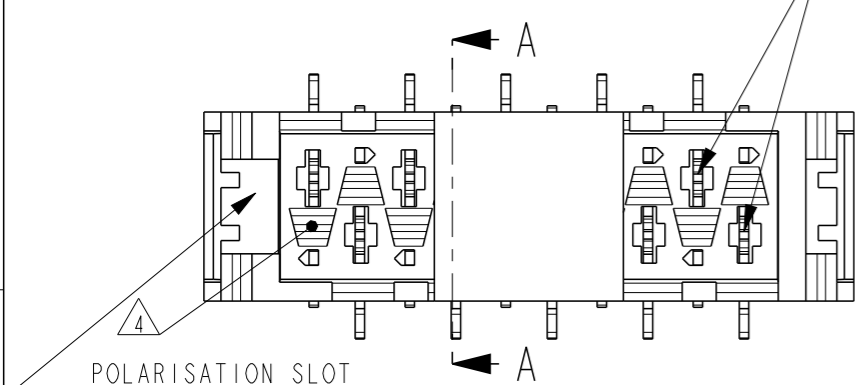

POLARISATION SLOT

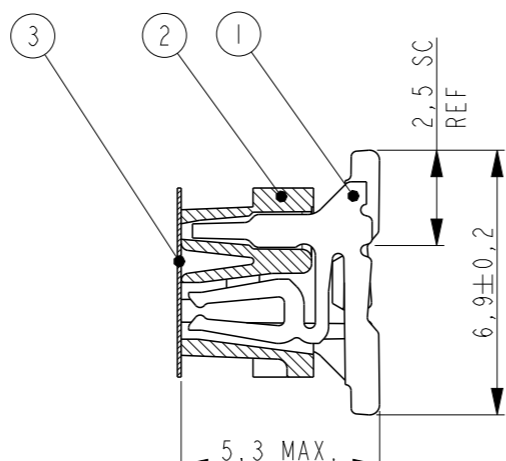

SECTION A-A

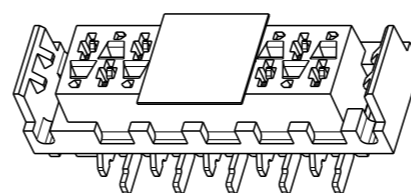

SCALE 3:1

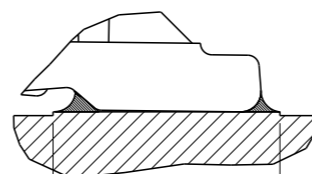

SOLDER DETAIL
SCALE 10:1

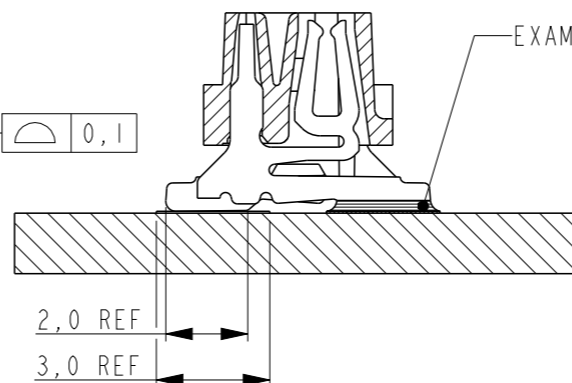

EXAMPLE SOLDER JOINT

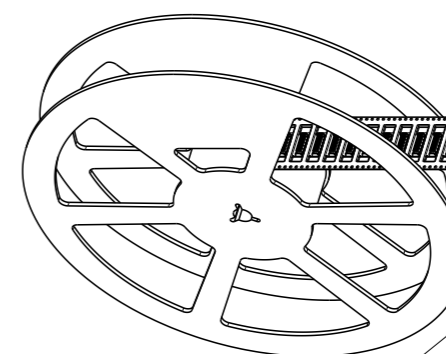

SEE DETAIL X

USER DIRECTION OF FEED

ACCORDING EIA-481/DIN IEC 286

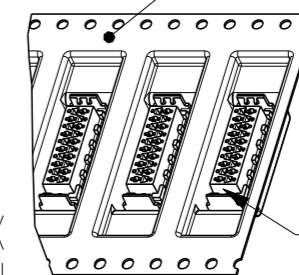

DETAIL X
SCALE 1:1

POLARIZATION-SLOT
ON THIS SIDE.

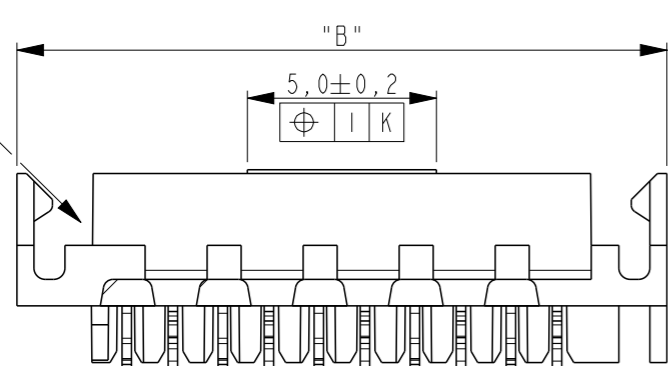

0,25±0,05 TYP.

0,5 M

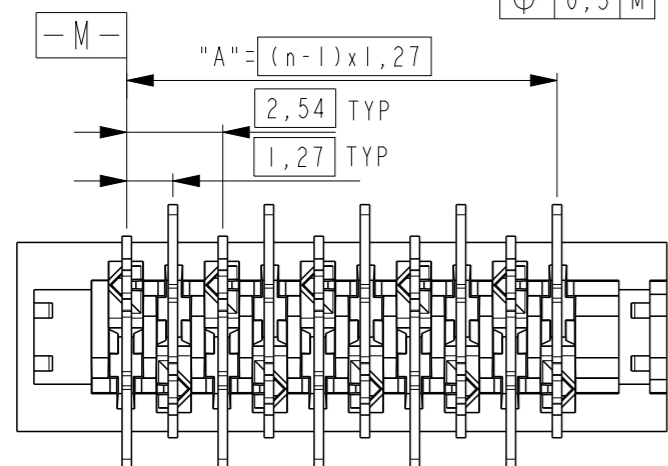

NOTES:

- 1 TAPE FOR VACUUM P&P ONLY FOR DASH NUMBERS 7- /8- /9-
- 2 FOR PACKAGING SEE SHEET 2 AND 3
- 3 WITHOUT VACUUM TAPE.
- 4 CORING-OUTS FOR MANUFACTURING PURPOSE ONLY.
SHAPE MAY VARY, BUT IS NOT FUNCTIONAL FOR THE APPLICATION.
- 5 SHOWN IS A 10 POSITION CONNECTOR.

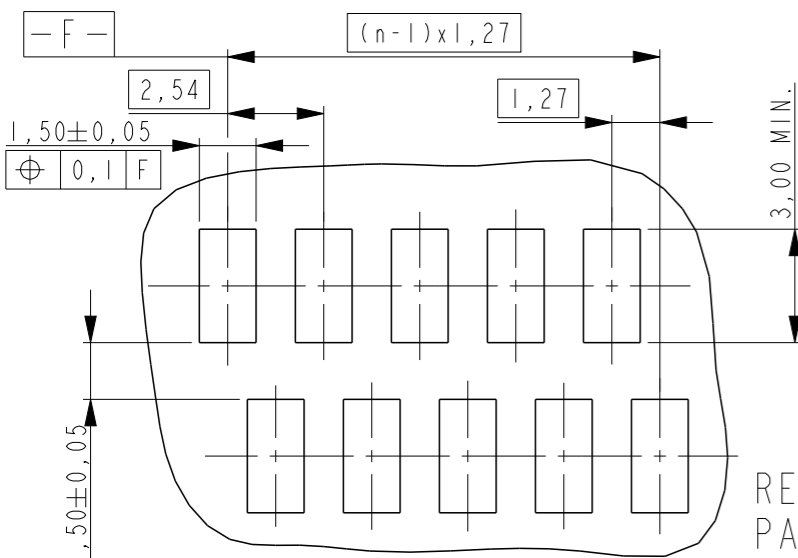

RECOMMENDED PC-BOARD
PAD-LAYOUT TOP VIEW

Item no.	Description	Material	Finish
3	PICK & PLACE TAPE	KAPTON	AMBER TRANSPARENT
2	FEMALE HOUSING	POLYAMIDE 4/6,GF	BLACK
1	FEMALE CONTACT	TIN BRASS	TIN(3-5µ) OVER NICKEL

THIS DRAWING IS A CONTROLLED DOCUMENT.

DIMENSIONS:	TOLERANCES UNLESS OTHERWISE SPECIFIED:
mm	
	0 PLC ±-
	1 PLC ±-
	2 PLC ±-
	3 PLC ±-
	4 PLC ±-
	ANGLES ±-
MATERIAL	FINISH
SEE TABLE	SEE TABLE

DWN	25SEP2014
NAGASHREE, V	
CHK	26SEP2014
PRASHANTH, S	
APVD	26SEP2014
JAYANTH	
PRODUCT SPEC	
108-32087	
APPLICATION SPEC	
114-13318	
WEIGHT	-

STE TE Connectivity

NAME			
MICRO-MATCH VALUE LINE FEMALE-ON-BOARD TOP-ENTRY, SMD CONNECTOR WITH LATCHES			
SIZE	CAGE CODE	DRAWING NO	RESTRICTED TO
A3	00779	C-2823056	-

Customer Drawing SCALE 5:1 SHEET 1 OF 3 REV A

THIS DRAWING IS UNPUBLISHED.

RELEASED FOR PUBLICATION

© COPYRIGHT -

ALL RIGHTS RESERVED.

LOC	DIST	REVISIONS					
		P	LTR	DESCRIPTION	DATE	DWN	APVD
-	-	-	-	SEE SHEET 1	-	-	-

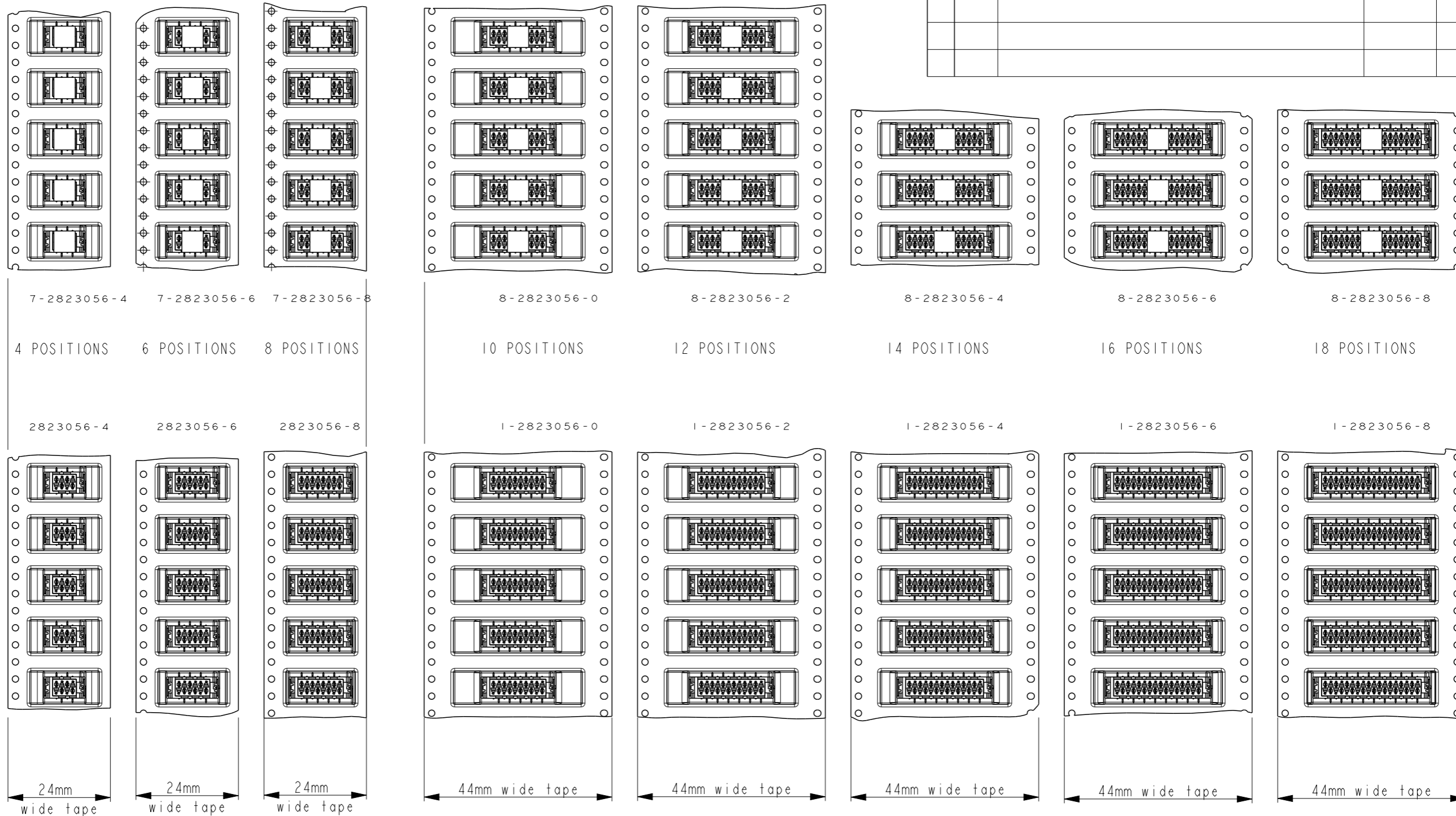

THIS DRAWING IS A CONTROLLED DOCUMENT.		DWN	25SEP2014	 TE Connectivity	NAME MICRO-MATCH VALUE LINE FEMALE-ON-BOARD TOP-ENTRY, SMD CONNECTOR WITH LATCHES.
DIMENSIONS: mm		CHK	26SEP2014		
TOLERANCES UNLESS OTHERWISE SPECIFIED:		APVD	26SEP2014		
0 PLC ±- 1 PLC ±- 2 PLC ±- 3 PLC ±- 4 PLC ±- ANGLES ±- FINISH -		PRODUCT SPEC	108-32087		
MATERIAL -		APPLICATION SPEC	114-13318	SIZE	A3
		WEIGHT	-	CAGE CODE	00779
		Customer Drawing		DRAWING NO	C-2823056
				RESTRICTED TO	-
				SCALE	4:1
				SHEET	2 OF 3
				REV	A

THIS DRAWING IS UNPUBLISHED.

RELEASED FOR PUBLICATION

© COPYRIGHT -

ALL RIGHTS RESERVED.

LOC - DIST -

REVISIONS

P	LTR	DESCRIPTION	DATE	DWN	APVD
-	-	SEE SHEET 1	-	-	-

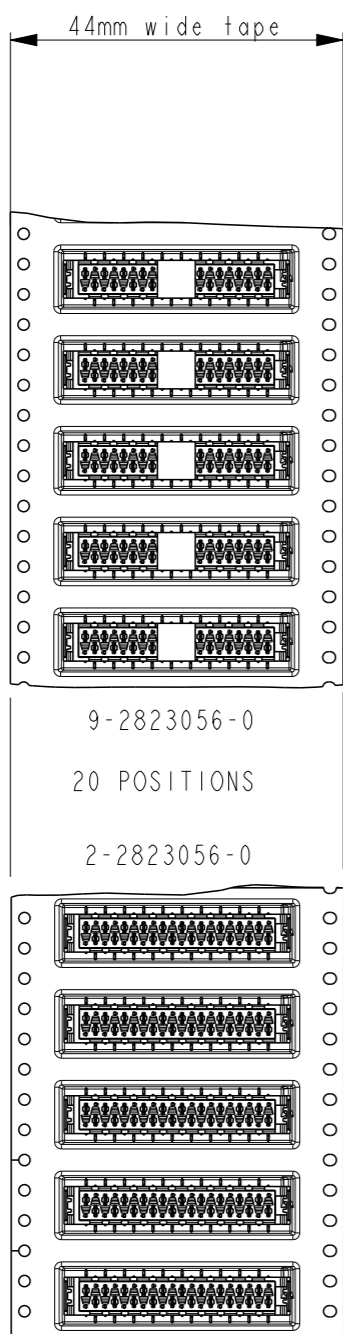

THIS DRAWING IS A CONTROLLED DOCUMENT.

DIMENSIONS:
mm

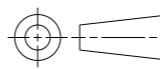

TOLERANCES UNLESS OTHERWISE SPECIFIED:

- 0 PLC ±
- 1 PLC ±
- 2 PLC ±
- 3 PLC ±
- 4 PLC ±
- ANGLES ±

MATERIAL -

FINISH -

DWN 25SEP2015
Nagashree.V

CHK 26SEP2014
Prashanth.S

APVD 26SEP2014
JAYANTH

PRODUCT SPEC
108-32087

APPLICATION SPEC
114-13318

WEIGHT -

Customer Drawing



NAME
MICRO-MATCH VALUE LINE
FEMALE-ON-BOARD TOP-ENTRY,
SMD CONNECTOR WITH LATCHES.

SIZE A3	CAGE CODE 00779	DRAWING NO C-2823056	RESTRICTED TO -
------------	--------------------	-------------------------	--------------------

SCALE 4:1 SHEET 3 OF 3 REV A