

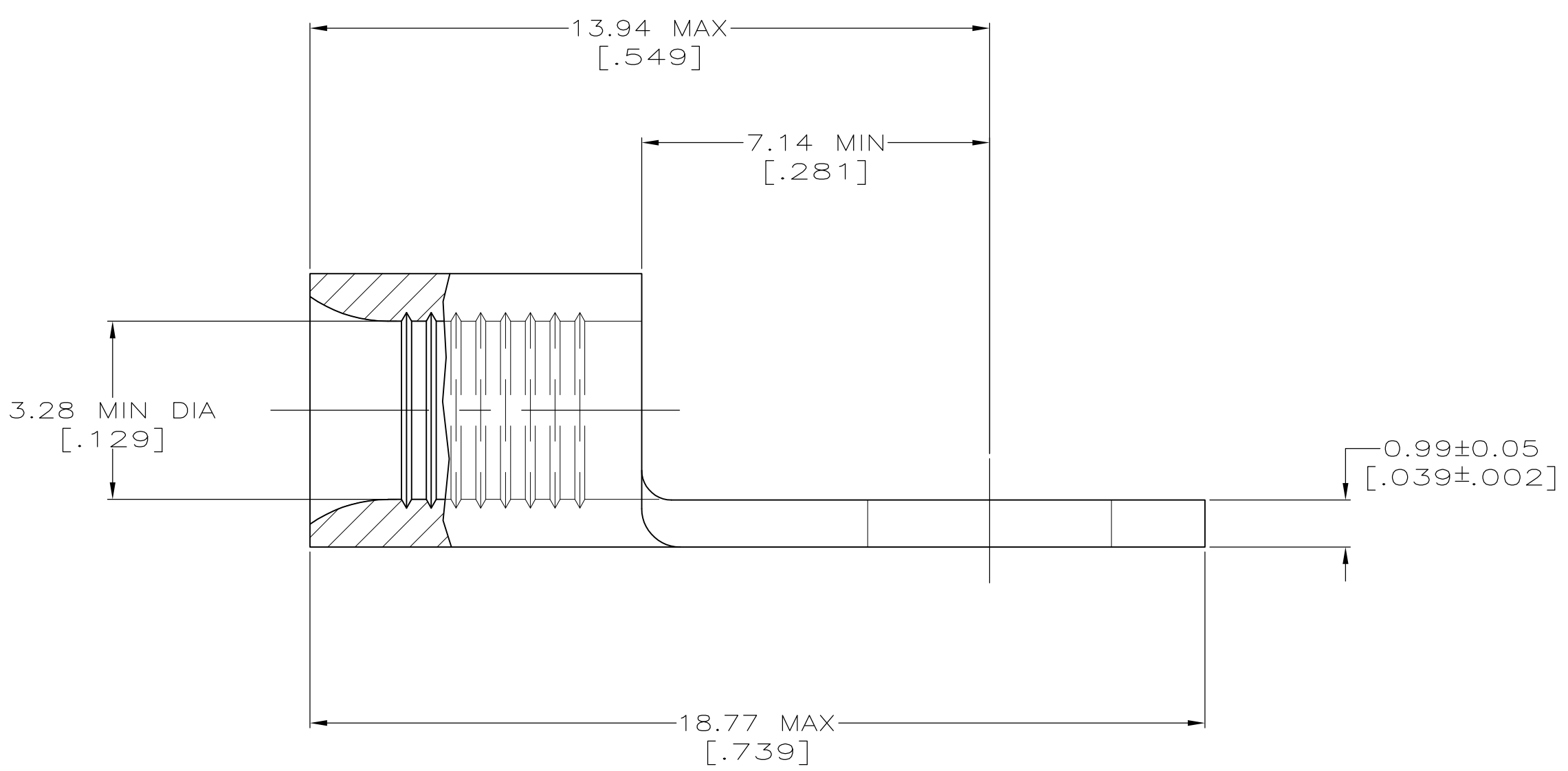

<b>AMP</b> WIRE RANGE	E13288 Listed
12-10 AWG SOLID OR STRANDED	NOT APPLICABLE
LR7189 Certified	MILITARY P/N AND CLASS
NOT APPLICABLE	NOT APPLICABLE

- ① STAMP AMP 12-10 APPROX AS SHOWN
- ② WIRE BARREL COLOR CODED ORANGE TO DENOTE NICKEL MATERIAL

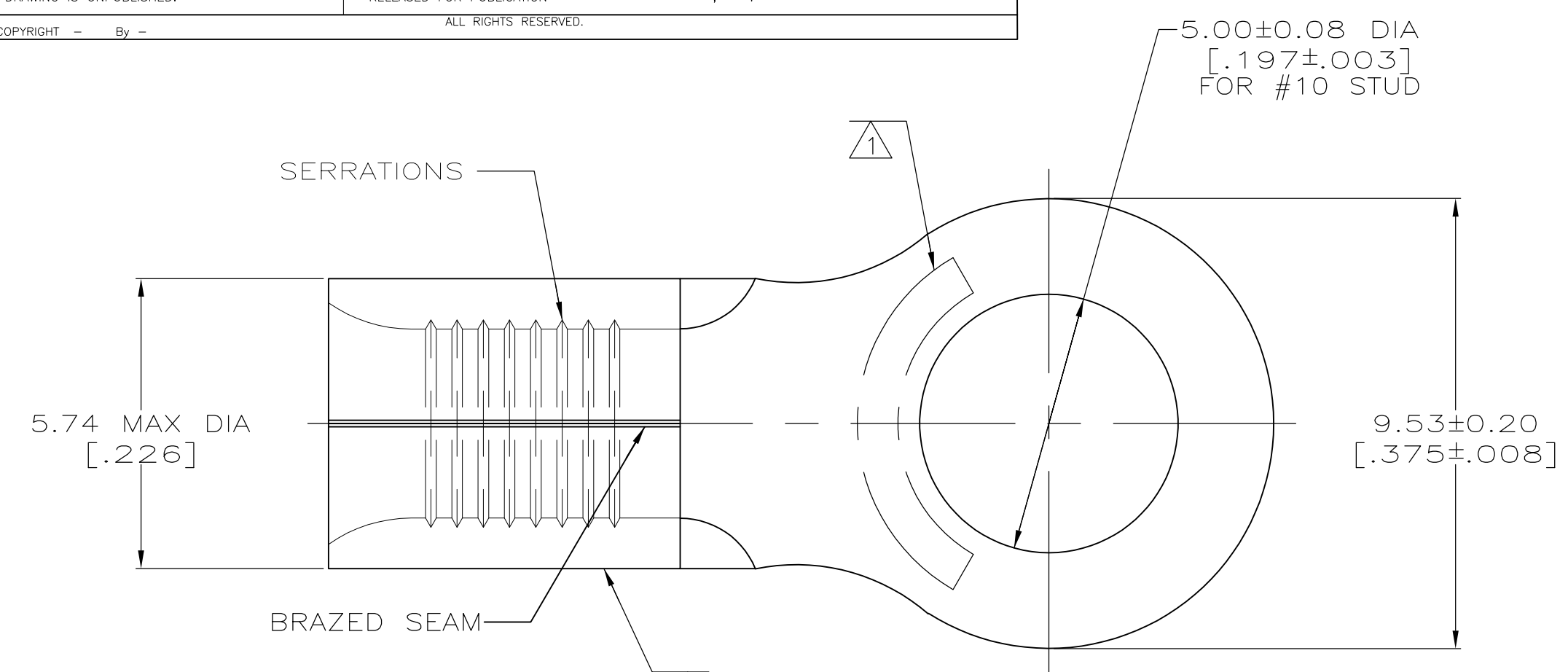

<b>AMP INCORPORATED CUSTOMER SERVICE SYSTEMS</b>		MAX RECOMMENDED OPERATING TEMPERATURE: 649° C MAX
FOR ADDITIONAL PRODUCT INFORMATION OR COPIES OF DRAWINGS AND TECHNICAL DOCUMENTS	PRODUCT INFORMATION CENTER 1-800-522-6752	VOLTAGE RATING: NOT APPLICABLE
FOR APPLICATION TOOLING INFORMATION	TOOLING ASSISTANCE CENTER 1-800-722-1111	WIRE CROSS SECTIONAL AREA RANGE: 2.62-6.64mm <sup>2</sup> [5,180-13,100] CIR MILS SOLID OR STRANDED
FOR ORDER ENTRY	1-800-526-5142	THIS DRAWING IS A CONTROLLED DOCUMENT FOR AMP INCORPORATED. IT IS SUBJECT TO CHANGE AND THE CONTROLLING ENGINEERING ORGANIZATION SHOULD BE CONTACTED FOR THE LATEST REVISION.

50	LOOSE PIECE, BOX	8-323680-2
2500	ON TAPE	2-323680-5
---	LOOSE PIECE	323680
QUANTITY	PACKAGING TYPE	PART NO

THIS DRAWING IS A CONTROLLED DOCUMENT.		DWN TA BRINKMAN 4-16-93	TE Connectivity																	
DIMENSIONS: mm [INCHES]		CHK DA PATTERSON 4-16-93																		
TOLERANCES UNLESS OTHERWISE SPECIFIED:		APVD DE MILLER 4-16-93																		
<table border="1"> <tr><td>0 PLC</td><td>±</td><td>-</td></tr> <tr><td>1 PLC</td><td>±</td><td>-</td></tr> <tr><td>2 PLC</td><td>±</td><td>-</td></tr> <tr><td>3 PLC</td><td>±</td><td>-</td></tr> <tr><td>4 PLC</td><td>±</td><td>-</td></tr> <tr><td>ANGLES</td><td>±</td><td>±</td></tr> </table>		0 PLC		±	-	1 PLC	±	-	2 PLC	±	-	3 PLC	±	-	4 PLC	±	-	ANGLES	±	±
0 PLC	±	-																		
1 PLC	±	-																		
2 PLC	±	-																		
3 PLC	±	-																		
4 PLC	±	-																		
ANGLES	±	±																		
MATERIAL NICKEL PER ASTM B-162 ANNEALED	FINISH -	WEIGHT -	SIZE A2																	
CUSTOMER DRAWING		CAGE CODE 00779	DRAWING NO G-323680																	
		RESTRICTED TO -	SCALE 10:1 SHEET 1 OF 1 REV J1																	