

THIS DRAWING IS UNPUBLISHED. RELEASED FOR PUBLICATION
 © COPYRIGHT - By - ALL RIGHTS RESERVED.

REVISIONS					
P	LTR	DESCRIPTION	DATE	DWN	APVD
	J	REVISED PER ECR-15-016073	06NOV2015	RZ	RS

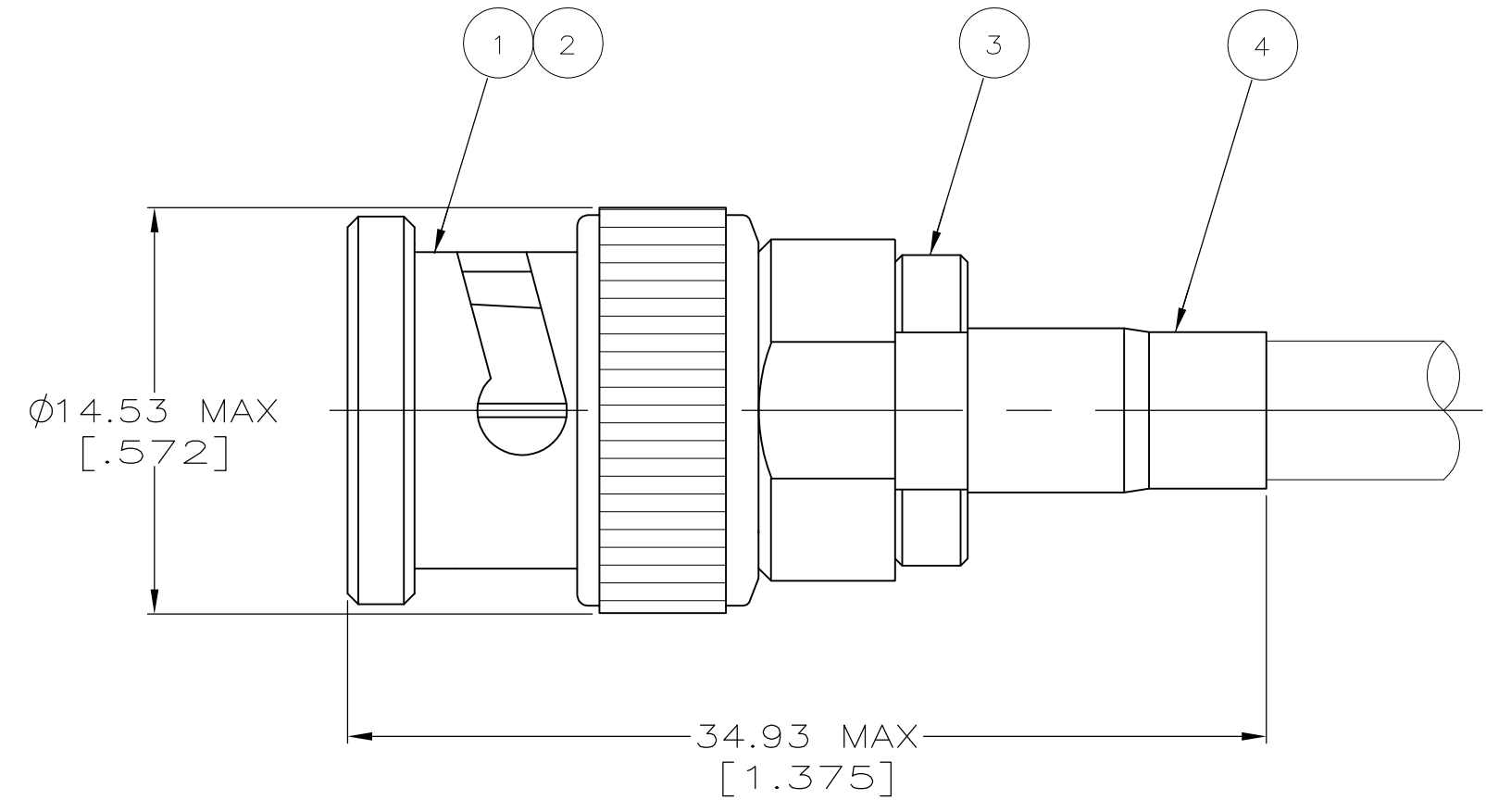

1. USE INSTRUCTION SHEET 1799-1
- △2 USE CRIMP TOOL 69140-1 WITH CABLE RG-58/U, 58A/U, 58B/U, 58C/U
- △3 USE CRIMP TOOL 69140-2 WITH CABLE RG-55/U, 55A/U, 55B/U AND 223/U

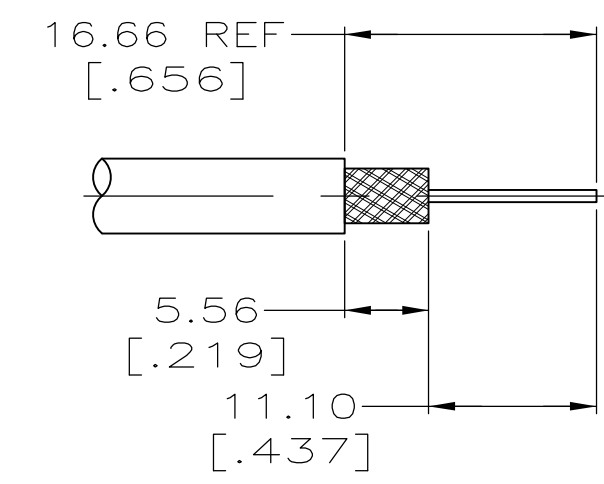

RECOMMENDED STRIP LENGTH
SCALE 2:1

OBSOLETE	-	-	-	-	7-329444-1
	△3 9-329099-2	9-50780-0	2-329106-1	9-329804-0	2-329444-2
	△2 9-328663-0	9-50780-0	2-329106-1	9-329804-0	2-329444-1
SUPERSEDED BY 2-329444-1	-	-	-	-	329444
	④ FERRULE QTY=1	③ CRIMP END ASSEMBLY QTY=1	② GASKET QTY=1	① PLUG ASSEMBLY QTY=1	PART NUMBER

THIS DRAWING IS A CONTROLLED DOCUMENT.

DIMENSIONS: mm [INCHES]	TOLERANCES UNLESS OTHERWISE SPECIFIED:	DWN MICHAEL E. COWHER 06FEB96	TE Connectivity NAME PLUG, BNC
	0 PLC ± - 1 PLC ± - 2 PLC ± 0.41 [.016] 3 PLC ± - 4 PLC ± - ANGLES ± -	CHK FRANK P. MORANA 15FEB96	
MATERIAL	FINISH	APVD FRANK P. MORANA 15FEB96	
		PRODUCT SPEC APPLICATION SPEC WEIGHT	
CUSTOMER DRAWING		SIZE A3	CAGE CODE 00779
		DRAWING NO C-329444	RESTRICTED TO
		SCALE 4:1	SHEET 1 OF 1
		REV J	