

THIS DRAWING IS UNPUBLISHED. RELEASED FOR PUBLICATION
 © COPYRIGHT - By - ALL RIGHTS RESERVED.

REVISIONS					
P	LTR	DESCRIPTION	DATE	DWN	APVD
K1		REVISED PER ECR-16-009453	30JUN2016	BW	RS

1. USE INSTRUCTION SHEET 1799-2

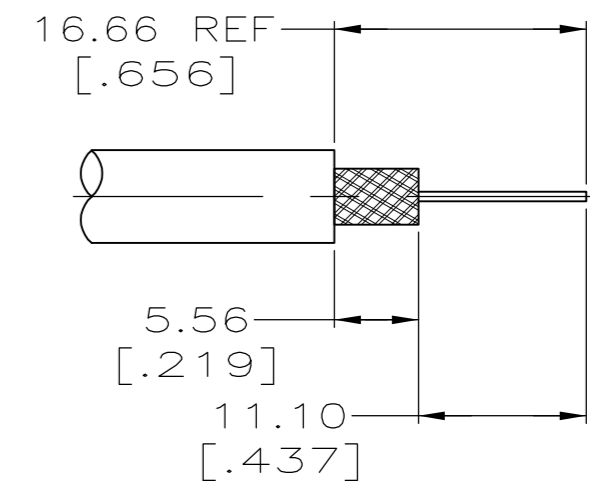
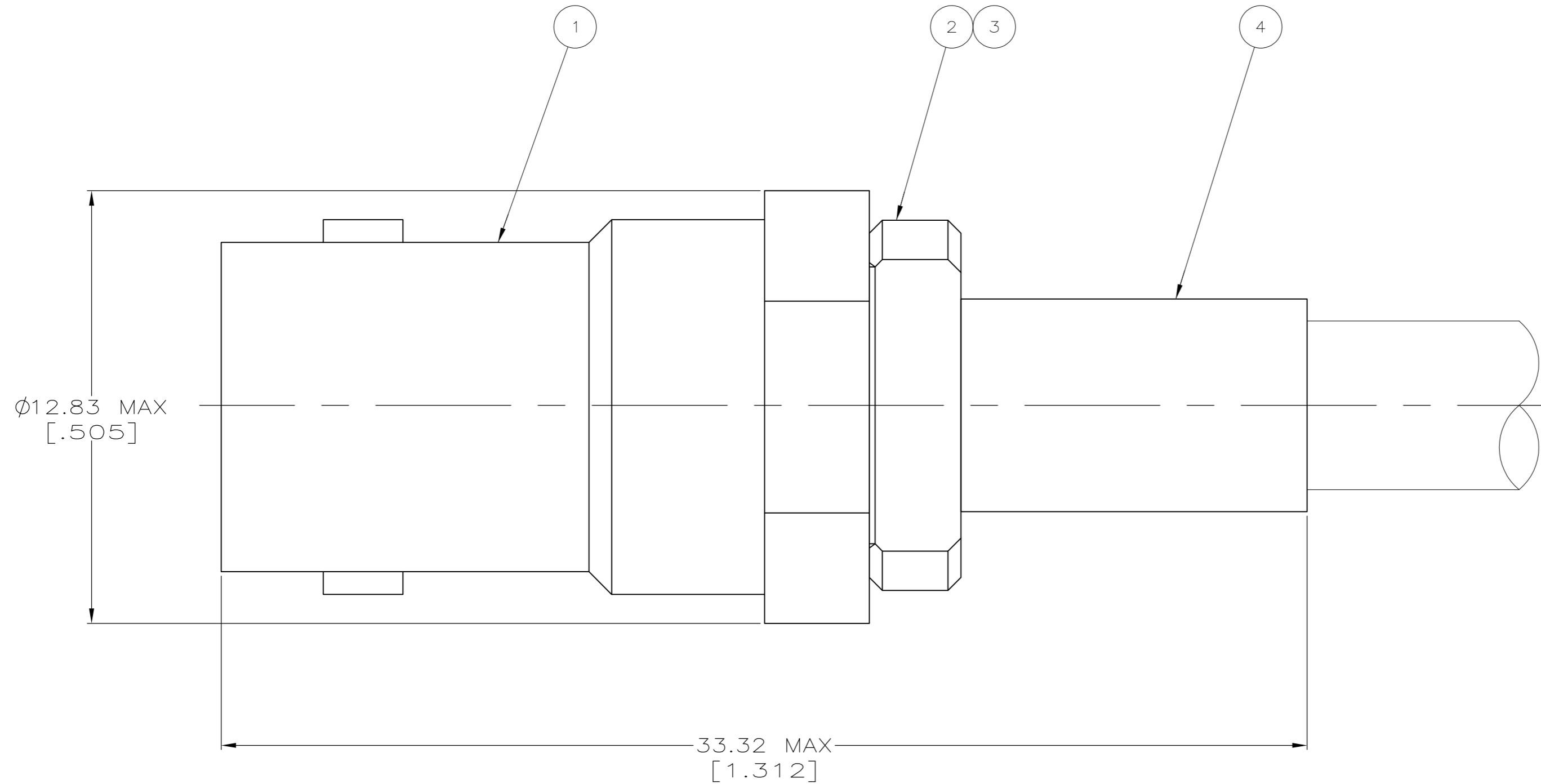

RECOMMENDED STRIP LENGTH
SCALE 2:1

OBSOLETE	RG-141 & 141A	69331-1	330478	50793-1	2-329106-1	329802	2-329452-3
	RG-142/U, 142A/U, AND 142B/U	69331-1	9-329099-2	50793-1	2-329106-1	329802	2-329452-2
SUPERSEDED BY 2-329545-1	RG-58/U, 58A/U, 58B/U, AND 58C/U	69140-1	328663	50793-1	2-329106-1	329802	2-329452-1
SUPERSEDED BY 2-329452-1	RG-58/U, 58A/U, 58B/U, AND 58C/U	69140-1	328663	50793-1	2-329106-1	329802	329452
	FOR USE WITH	CRIMP TOOL	④ FERRULE QTY=1	③ CRIMP END ASSEMBLY QTY=1	② GASKET QTY=1	① JACK ASSEMBLY QTY=1	PART NUMBER

Finish		Material		Part Number	
THIS DRAWING IS A CONTROLLED DOCUMENT.		DWN 14FEB96 MICHAEL E. COWHER		TE Connectivity	
DIMENSIONS: mm		CHK 15FEB96 FRANK P. MORANA		NAME JACK, BNC	
TOLERANCES UNLESS OTHERWISE SPECIFIED:		APVD 15FEB96 FRANK P. MORANA		SIZE A2	
0 PLC ± -		PRODUCT SPEC		CAGE CODE 00779	
1 PLC ± -		APPLICATION SPEC		DRAWING NO C=329452	
2 PLC ± 0.41 [0.016]		WEIGHT 0		RESTRICTED TO -	
3 PLC ± -		CUSTOMER DRAWING		SCALE 8:1	
4 PLC ± -		FINISH -		SHEET 1 OF 1	
ANGLES ± -				REV K1	