

THIS DRAWING IS UNPUBLISHED. RELEASED FOR PUBLICATION
 © COPYRIGHT BY TYCO ELECTRONICS CORPORATION. ALL RIGHTS RESERVED.

LOC	DIST	REVISIONS			
P	LTR	DESCRIPTION	DATE	DWN	APVD
G	14	D1	REV PER ECR 06-027811	30NOV06	JR TM

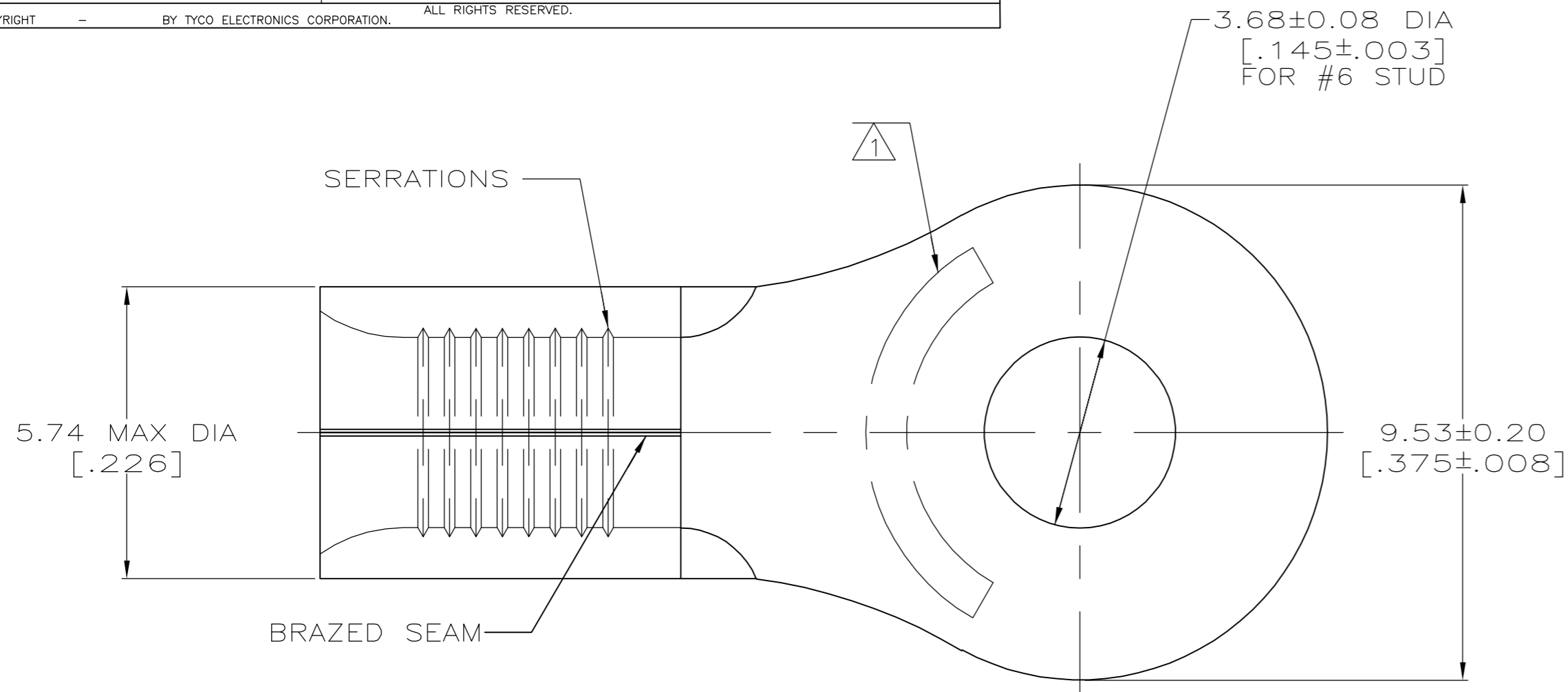

AMP WIRE RANGE	Listed FILE E13288	LR7189 Certified
12-10 AWG SOLID OR STRANDED	12-10 AWG STRANDED	12-10 AWG SOLID OR STRANDED

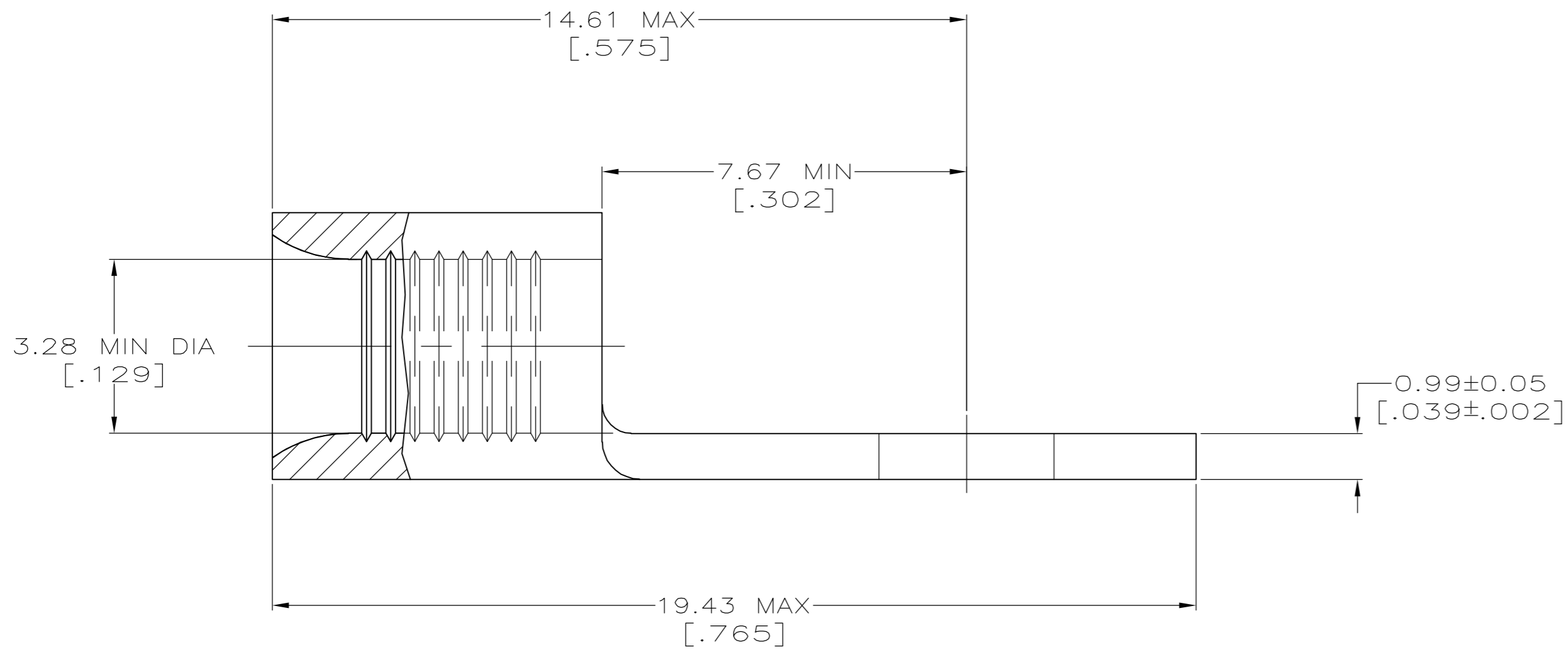

- 1 STAMP AMP 12-10* APPROX AS SHOWN
- 2 TIN PLATE 0.00254 [.000100] MIN THK PER ASTM B-545
- 3 CLEANED, UNPLATED.
- 4 GOLD PLATE 0.00127 [.000050] MIN THK PER MIL-G-45204 OVER NICKEL PLATE 0.00076 [.000030] MIN THK PER QQ-N-290.
- 5 TIN/LEAD (93.7) PLATE PER ASTM-B545 (3% MIN LEAD CONTENT).
- 6 COPPER PER ASTM B-152, ANNEALED
- 7 PRELIMINARY - NOT FOR PRODUCTION

QTY	FINISH	PACKAGING TYPE	PART NO.
500	4	LOOSE PIECE	33456-5
500	3	LOOSE PIECE	33456-4
2500	2	ON TAPE	2-33456-1
500	5	LOOSE PIECE	33456-1
500	2	LOOSE PIECE	33456

AMP INCORPORATED CUSTOMER SERVICE SYSTEMS		MAX RECOMMENDED OPERATING TEMPERATURE: 170°C
FOR ADDITIONAL PRODUCT INFORMATION OR COPIES OF DRAWINGS AND TECHNICAL DOCUMENTS	PRODUCT INFORMATION CENTER 1-800-522-6752	VOLTAGE RATING: N/A
FOR APPLICATION TOOLING INFORMATION	TOOLING ASSISTANCE CENTER 1-800-722-1111	CIRCULAR MIL AREA: 2.62-6.64mm ² [5,180-13,100] SOLID OR STRANDED
FOR ORDER ENTRY	1-800-526-5142	THIS DRAWING IS A CONTROLLED DOCUMENT FOR AMP INCORPORATED. IT IS SUBJECT TO CHANGE AND THE CONTROLLING ENGINEERING ORGANIZATION SHOULD BE CONTACTED FOR THE LATEST REVISION.

THIS DRAWING IS A CONTROLLED DOCUMENT.		DWN TA BRINKMAN 3-17-93	tyco Tyco Electronics Corporation Harrisburg, PA 17105-3608	
DIMENSIONS: INCHES		CHK DA PATTERSON 3-17-93	NAME TERMINAL, RING TONGUE, SOLISTRAND	
TOLERANCES UNLESS OTHERWISE SPECIFIED:		APVD JL MECKLEY 3-17-93	PRODUCT SPEC	
0 PLC ± -		APPLICATION SPEC		
1 PLC ± -		WEIGHT -		
2 PLC ± -		SIZE A2		
3 PLC ± -		CAGE CODE 00779		
4 PLC ± -		DRAWING NO C=33456		
ANGLES ± -		RESTRICTED TO -		
MATERIAL - 6	FINISH SEE NOTES	SCALE 10:1 SHEET 1 of 1 REV D1		
CUSTOMER DRAWING				