

DRAWING MADE IN AMERICAN PROJECTION

LOC **G** PRINT DIST **14 C**

©1947 BY AMP INCORPORATED. ALL RIGHTS RESERVED. AMP PRODUCTS COVERED BY PATENTS AND/OR PATENTS PENDING.

REVISIONS

| LTR | DESCRIPTION               | DATE     | APPROVED |
|-----|---------------------------|----------|----------|
| A   | REDRAWN & UPDATED PC-5558 | 10-3-69  | JM       |
| B   | REV. & ADDED TAPE NO.     | 5-11-71  | FEY      |
| C   | INACTIVATED 2-1 P-9241    | 11-30-81 | JFM      |
| C1  | REV PER ECR 06-024909     | 10/26/06 | JR/TM    |

34101

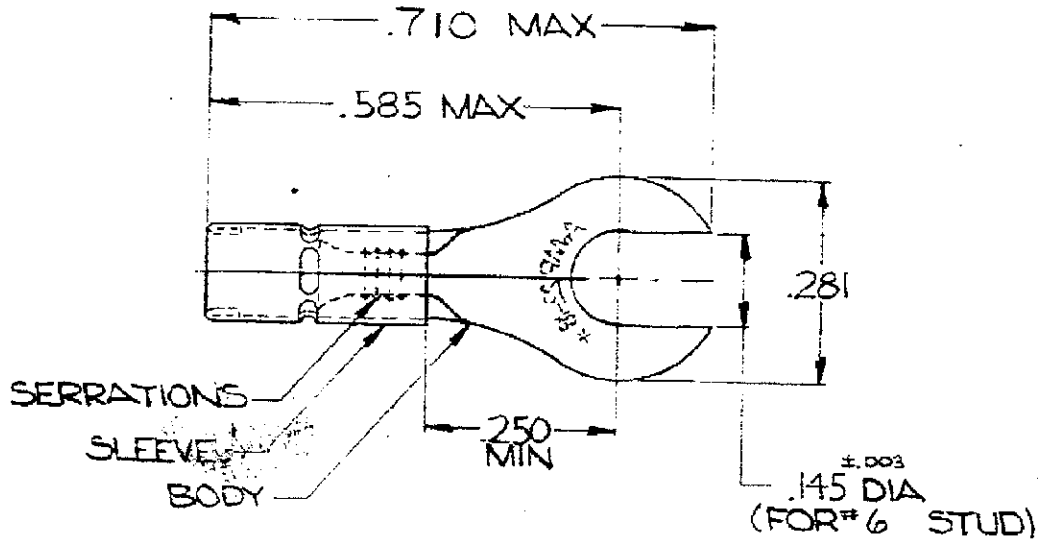

TONGUE MATERIAL THICKNESS =  $\pm .002$  .031  
 FOR .080 TO .125 WIRE INSULATION DIA  
 MARKING 22-18 FOR MILITARY  
 COMMERCIAL RANGE 22-16

|          |                  |
|----------|------------------|
| 34101    | 2-34101-1        |
| PART NO. | PART NO. ON TAPE |

|   |                                 |   |
|---|---------------------------------|---|
| UNLESS OTHERWISE SPECIFIED DIMENSIONS ARE IN INCHES<br>TOLERANCES ON:<br>DECIMALS ± .008<br>ANGLES ± 5° | CONTRACT NO. —                  | <b>AMP</b><br>AMP INCORPORATED<br>HARRISBURG, PENNSYLVANIA            |
|   | DR. <i>H. Benoit 9/2/69</i>     |   |
| MATERIAL<br>COPPER<br>(QQ-C-576)<br><br>TIN PL<br>(L-T-10727)   | CHK. <i>JM Eversman 10-5-69</i> | WIRE TERMINAL<br>DIAMOND GRIP-SLOTTED RING TONGUE<br>WIRE SIZE: 22-16 |
|   | APPD. <i>Swabel 10-6-69</i>     |   |
|   | REC. <i>JM Eversman 10-6-69</i> | A 00779 34101   |
|   | DSGN APPD.                      | SCALE NTS SHEET 1 OF 1  |
|   | OTHER APPD.                     |   |