

8 | 7 | 6 | 5 | 4 | 3 | 2 | 1

DO NOT SCALE DIMENSIONS IN MM. 

U.A.D. FILE CODE
S.C344070.A

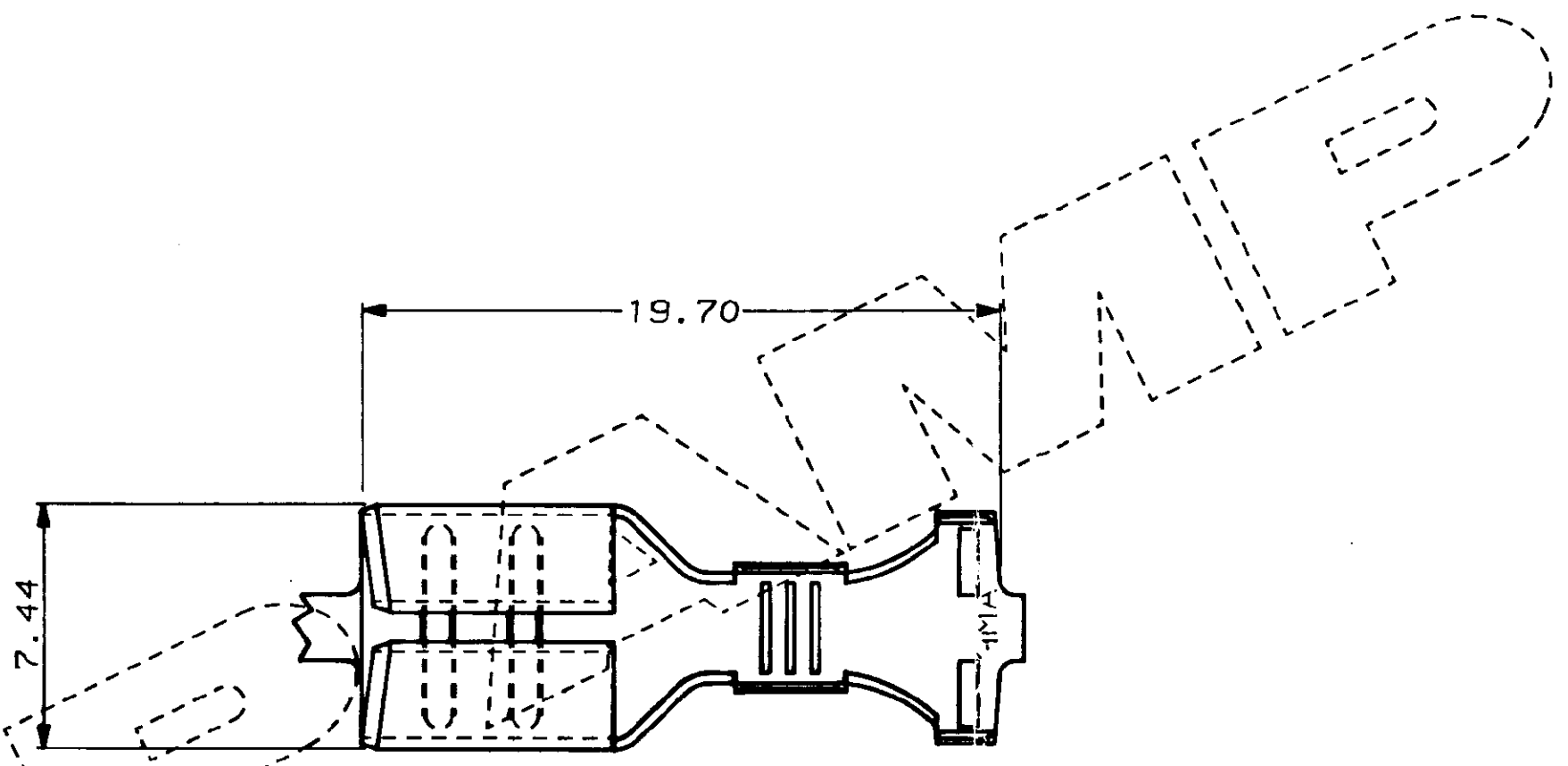

GAP TO SUIT 0.81 TAB

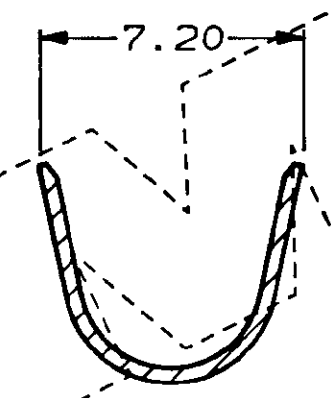
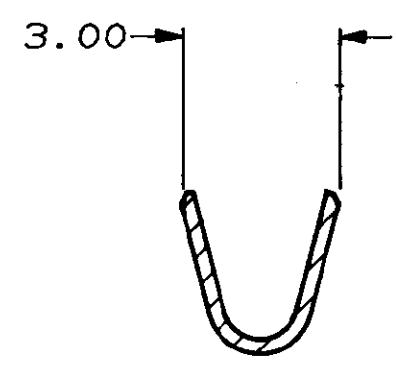
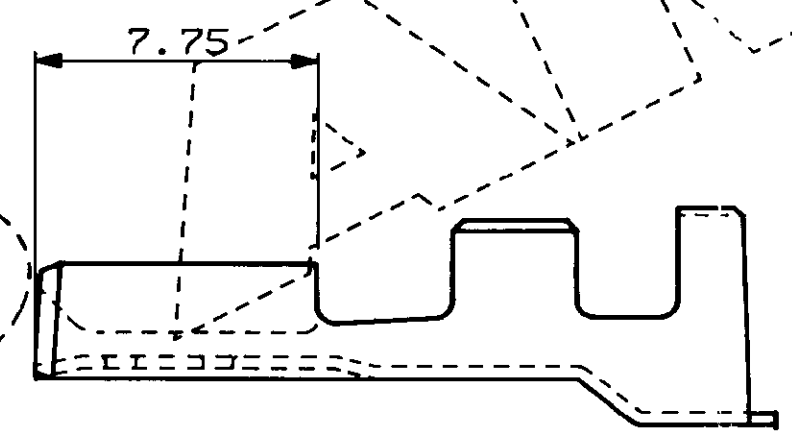
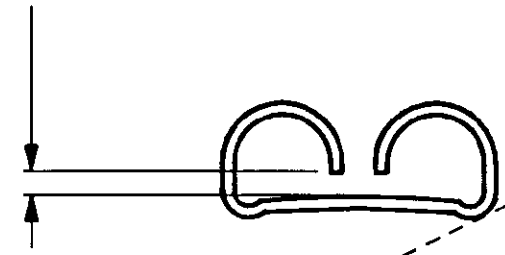

WIRE RANGE 0.50 TO 1.50 MM²
 INS. RANGE 4.10 TO 5.50 MM DIA. INC. SEAL
 (ONLY THIN WALLED CABLE 1.60 TO 2.40 MM DIA. IS SUITABLE)

TIN PLATED		BRASS		344070-1	
FINISH		MATERIAL		PART NUMBER	
CUSTOMER DWG FOR REFERENCE ONLY		©COPYRIGHT 1987 BY AMP OF GREAT BRITAIN LTD. ALL INTERNATIONAL RIGHTS RESERVED. ALL PRODUCTS MAY BE COVERED BY BRITISH AND FOREIGN PATENTS AND/OR PATENTS PENDING.		24/06/87 DR. R. RUNAGALL.	
-		TOLERANCES UNLESS OTHERWISE STATED :		APP. B. J.	
-		DEC ± 0.5		 TERMINAL HOUSE STANMORE MIDDX.	
-		ANGLES ± 1°		NAME .250 SERIES REC. HIGH CURRENT	
-				ECONOSEAL 3 (SEALED APPLICATIONS)	
B	EBAO-0029-03	R.S.	12.8.03	SCALE	LOC
REV	ECN	DRN	DATE	5/1	E
				SIZE	DWG. No.
				A2	C344070
				REV	SHEET
				B	1/1

FORMAT 22/05/85 8 | 7 | 6 | 5 | 4 | 3 | 2 | 1