

PROPER USE GUIDELINES

Cumulative Trauma Disorders can result from the prolonged use of manually powered hand tools. Hand tools are intended for occasional use and low volume applications. A wide selection of powered application equipment for extended-use, production operations is available.

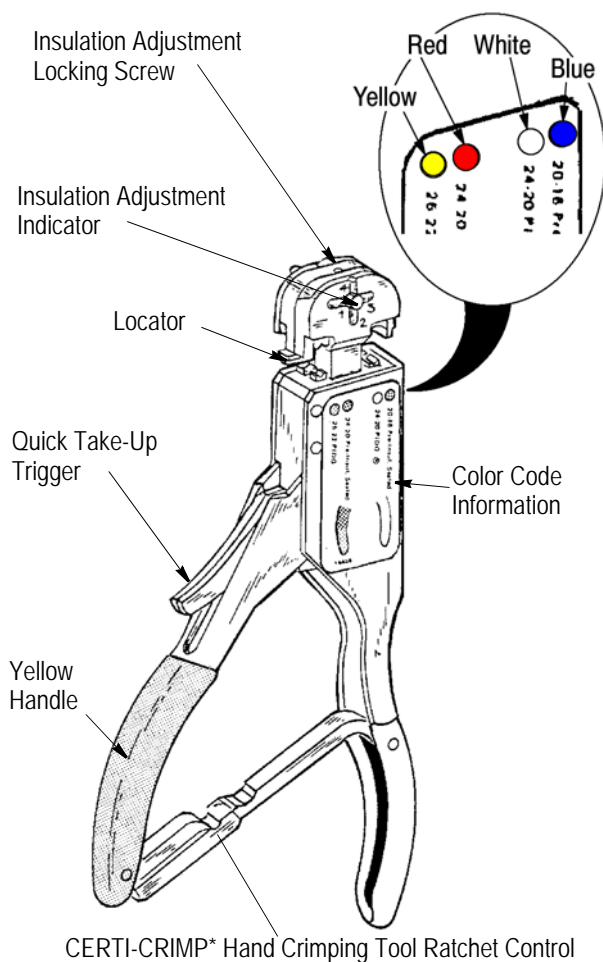

Figure 1

1. INTRODUCTION

This instruction sheet covers the use of "T"-HEAD Crimping Tools 59170, 59250, 59275, 59300, 69692-1, and 69693-1. See Figure 1. These tools crimp:

- PIDG* vinyl and nylon terminals and splices on stranded copper wire sizes 26 through 14.
- STRATO-THERM* terminals on stranded copper wire sizes 26 through 14.
- PIDG Insulation Restricting Nylon Terminals on stranded copper wire sizes 26 through 14.

- PIDG insulation restricting terminals with TEFLON[®] coating, used on stranded copper wire sizes 26 through 14.
- PIDG Radiation Resistant Terminals and Splices on stranded copper wire sizes 26 through 14.
- PLASTI-GRIP* Terminals on solid or stranded copper wire sizes 22 through 14.
- PLASTI-GRIP Butt Splices on solid or stranded copper wire sizes 26 through 22.
- Spare Wire Caps on solid or stranded copper wire sizes 22 through 14.

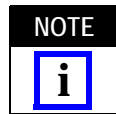

Dimensions on this sheet are in millimeters [with inch equivalent dimensions in brackets]. Figures and illustrations are for identification only and are not drawn to scale.

Reasons for reissue of this sheet are provided in Section 9, REVISION SUMMARY.

2. DESCRIPTION

The handles of the crimping tools are color-coded to match the color coding of the product to be applied.

The insulation adjustment indicator is used to control crimp height of the insulation barrel. It can be set at any of four positions corresponding to insulation diameter.

Tools also feature a locator, quick take-up trigger, and color code information.

The CERTI-CRIMP hand crimping tool ratchet control ensures full crimping of the product. Once engaged, the ratchet will not release until the handles have been FULLY closed.



The crimping dies bottom before the ratchet releases. This is a design feature that ensures maximum electrical and tensile performance of the crimp. Do NOT re-adjust the ratchet.

3. COLOR AND DOT CODING

Note that tool handles and terminal, splice and cap insulation are color coded for a given wire range as listed in Figure 2. Crimp the color coded terminal, splice or cap in the matching color coded portion of the tool. For example, when using Hand Tool 59275, yellow coded PIDG terminals and splices and red coded pre-insulated seated splices must be crimped in that portion of tool displaying the red and yellow coded dots and yellow handle. See Figure 1.

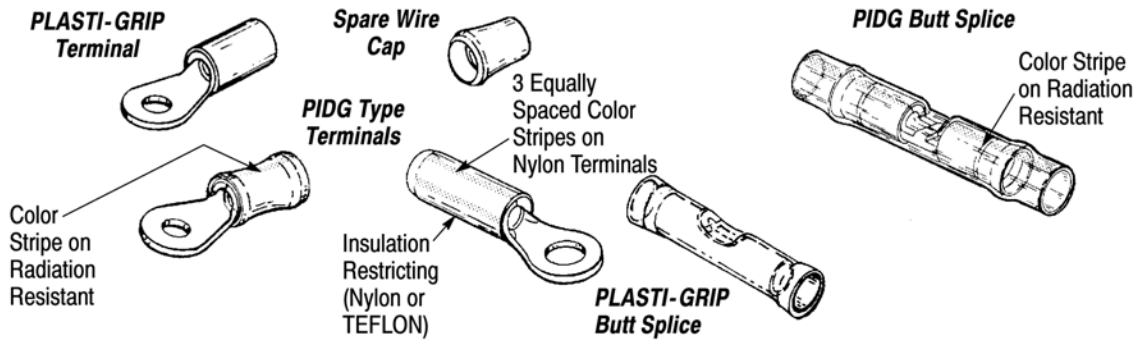

PRODUCT	TOOL NO. AND HANDLE COLOR CODE	DOT CODE	WIRE RANGE OR SIZE	WIRE INSULATION DIAMETER RANGE	INSULATION COLOR CODE	WIRE STRIP LENGTH				
						Terminals		Splices		
						Min.	Max.	Min.	Max.	
PIDG INSULATION RESTRICTING NYLON TERMINALS MS 7928/1-1 through -10	59170 59250 RED AND BLUE	ONE DOT	26	0.66-1.40 [.026 - .055]	YELLOW W/3 BLACK STRIPES	6.35 [.25]	7.11 [.28]	—	—	
			24	0.79-1.40 [.031 - .055]	YELLOW W/3 BLUE STRIPES					
PIDG TERMINALS MS 25036-143 through -147 (Class 1 Only)		ONE DOT	26 - 24	—	YELLOW	5.08 [.20]	5.84 [.23]	—	—	
PIDG RADIATION RESISTANT TERMINALS MS 7928/4-143 through -147					NATURAL W/YELLOW STRIPE					
PIDG VINYL & NYLON TERM. OR SPLICE & 26-22 AWG PLASTI-GRIP BUTT SPLICE		59275 YELLOW AND WHITE	ONE DOT	26 - 22	—	YELLOW	4.06 [.16]	4.83 [.19]	4.32 [.17]	5.08 [.20]
			TWO DOTS	24 - 20	—	WHITE	4.83 [.19]	5.59 [.22]	5.59 [.22]	6.35 [.25]
PIDG VINYL AND NYLON TERMINALS AND SPLICES ALSO PLASTI-GRIP 22-16 AND 16-14 TERMINALS		59300 RED AND WHITE	TWO DOTS	24 - 20	—	WHITE	4.83 [.19]	5.59 [.22]	5.59 [.22]	6.35 [.25]
			ONE DOT	22 - 16	—	RED	5.08 [.20]	5.84 [.23]	6.35 [.25]	7.11 [.28]
		59170 59250 RED AND BLUE	ONE DOT	22 - 16	—	RED	5.08 [.20]	5.84 [.23]	6.35 [.25]	7.11 [.28]
			TWO DOTS	16 - 14	—	BLUE				
PIDG RADIATION RESISTANT TERMINALS AND SPLICES	59275 YELLOW AND WHITE	ONE DOT	26 - 24	SPLICE ONLY	NATURAL W/YELLOW STRIPE	—	—	4.32 [.17]	5.08 [.20]	
		TWO DOTS	24 - 20	—	NATURAL W/WHITE STRIPE	4.83 [.19]	5.59 [.22]	5.59 [.22]	6.35 [.25]	
	59300 RED AND WHITE	ONE DOT	26 - 24	TERMINALS ONLY	NATURAL W/YELLOW STRIPE	5.08 [.20]	5.84 [.23]	—	—	
		TWO DOTS	24 - 20	—	NATURAL W/WHITE STRIPE	4.83 [.19]	5.59 [.22]	5.59 [.22]	6.35 [.25]	
		ONE DOT	22 - 16	—	NATURAL W/RED STRIPE	5.08 [.20]	5.84 [.23]	6.35 [.25]	7.11 [.28]	
	59170 59250 RED AND BLUE	ONE DOT	26 - 24	TERMINALS ONLY	NATURAL W/YELLOW STRIPE	5.08 [.20]	5.84 [.23]	—	—	
		TWO DOTS	22 - 16	—	NATURAL W/RED STRIPE					
		ONE DOT	16 - 14	—	NATURAL W/BLUE STRIPE					5.08 [.20]
	PIDG INSULATION RESTRICTING NYLON TERMINALS	59275 YELLOW AND WHITE	ONE DOT	26	0.66-1.40 [.026 - .055]	YELLOW W/BLACK STRIPE	4.83 [.19]	5.59 [.22]	—	—
				24	0.79-1.40 [.031 - .055]	YELLOW W/BLUE STRIPE				
22				0.97-2.79 [.038 - .110]	RED W/GREEN STRIPE					
59300 RED AND WHITE		ONE DOT	20	1.17-2.79 [.046 - .110]	RED W/RED STRIPE	6.35 [.25]	7.11 [.28]	—	—	
			18	1.42-2.79 [.056 - .110]	RED W/WHITE STRIPE					
			22	0.97-2.79 [.038 - .110]	RED W/GREEN STRIPE					
59170 RED AND BLUE		ONE DOT	20	1.17-2.79 [.046 - .110]	RED W/RED STRIPE					
			18	1.42-2.79 [.056 - .110]	RED W/WHITE STRIPE					
			TWO DOTS	16	1.60-3.30 [.063 - .130]					BLUE W/BLUE STRIPE
14		1.98-3.30 [.078 - .130]	BLUE W/GREEN STRIPE							

Figure 2 (Cont'd)

PRODUCT	TOOL NO. AND HANDLE COLOR CODE	DOT CODE	WIRE RANGE OR SIZE	WIRE INSULATION DIAMETER RANGE	INSULATION COLOR CODE	WIRE STRIP LENGTH			
						Terminals		Splices	
						Min.	Max.	Min.	Max.
PIDG STRATO-THERM TERMINALS	69692-1 BLACK AND GREEN	ONE DOT	26 - 24	—	BLACK	4.06 [.16]	4.83 [.19]	—	—
		TWO DOTS	22 - 20	—	GREEN				
	69693-1 ORANGE AND WHITE	ONE DOT	18 - 16	—	ORANGE	5.08 [.20]	5.84 [.23]	—	—
		TWO DOTS	14	—	WHITE				
PIDG INSULATION RESTRICTING TEFLON STRATO-THERM TERMINALS	69692-1 BLACK AND GREEN	ONE DOT	26	0.66-1.40 [.026 - .055]	BLACK	4.83 [.19]	5.59 [.22]	—	—
			24	0.79-1.40 [.031 - .055]	BLUE				
		TWO DOTS	22	0.97-2.79 [.038 - .110]	GREEN	6.35 [.25]	7.11 [.28]	—	—
			20	1.17-2.79 [.046 - .110]	RED				
	69693-1 ORANGE AND WHITE	ONE DOT	18	1.42-2.79 [.056 - .110]	WHITE	6.35 [.25]	7.11 [.28]	—	—
			16	1.60-3.30 [.063 - .130]	BLUE				
		TWO DOTS	14	1.98-3.30 [.078 - .130]	GREEN				

PRODUCT	TOOL NO. AND HANDLE COLOR CODE	DOT CODE	WIRE RANGE	SEAL LINER COLOR CODE	INSULATION COLOR CODE	WIRE STRIP LENGTH	
						Min.	Max.
SPARE WIRE CAP NO. 328307	59250 AND 59170 RED AND BLUE	ONE DOT	22 - 18	—	RED	7.87 [.31]	8.64 [.34]
SPARE WIRE CAP NO. 328308		TWO DOTS	16 - 14	—	BLUE		

Figure 2 (End)

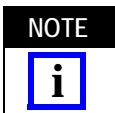

Refer to tool label for color code information. Note that Figure 2 indicates the number of dots that appear embossed on a crimped terminal, splice or cap. Observe the dot code on finished crimp to insure that correct product and tool combination was used.

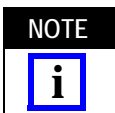

Dot code will disappear after heat sealing environment sealed splices.

4. WIRE STRIPPING AND CRIMPING PROCEDURES

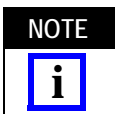

Refer to Section 5 for insulation crimp adjustment.



Do not re-terminate the splices or terminals.

4.1. PIDG and PLASTI-GRIP Terminals and Splices

1. Strip wire to dimensions listed in Figure 2.

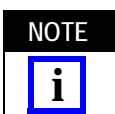

Do not use wires with nicked or missing conductor strands

2. Open crimping dies by closing handles until ratchet releases. See Figure 1. Note, that once ratchet is engaged, handles cannot be opened until they are first fully closed.

Crimp the color coded terminals and splices in the matching color coded portion of the tool. Refer to Section 3.

3. Place terminal in crimping dies so that terminal tongue slides under locator. See Figure 3.

4. Raise locator and place splice under locator as shown in Figure 4. Splice window indent faces top of tool.

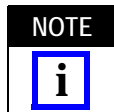

To properly position pre-insulated sealed splice, apply and maintain pressure against end of splice until Step 5 is completed. See Figure 4.

5. Press quick take-up trigger and close handles until terminal or splice is held firmly in place. Do not deform terminal or splice wire barrel.

6. Insert stripped wire into terminal until conductor butts against locator. See Figure 3. Insert stripped wire into splice until conductor butts against splice wire stop. See Figure 4.

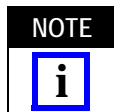

Do not allow wire insulation to enter wire barrel.

7. Hold wire in position and complete crimp by closing handles until the ratchet releases.

8. Refer to Section 6 and Figure 6 or Figure 7 for terminal or splice "Crimp Inspection" procedure.

PIDG and PLASTI-GRIP Terminals

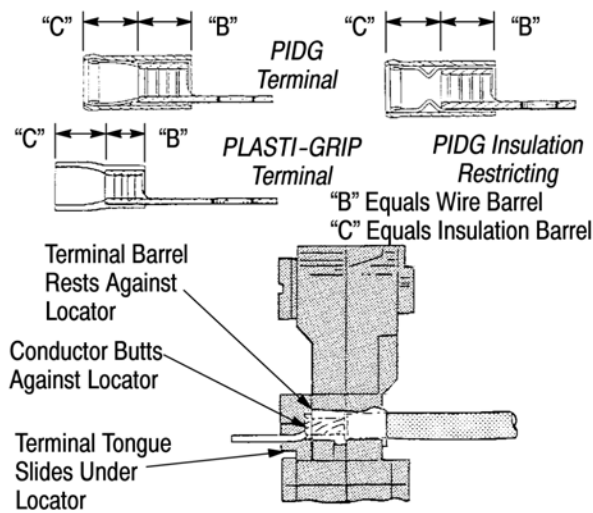
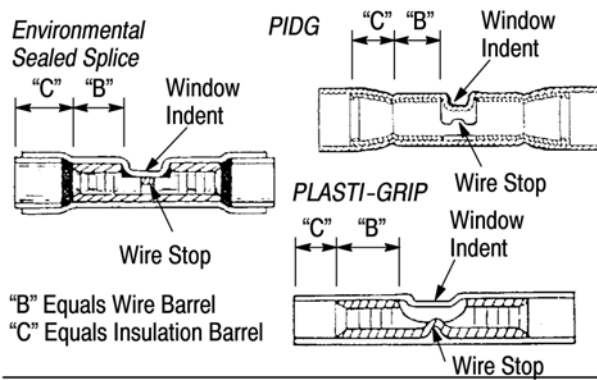
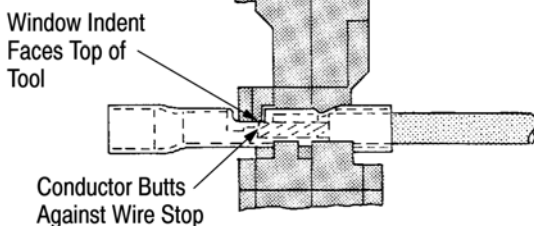

Figure 3

BUTT Splices



First Crimp



Second Crimp

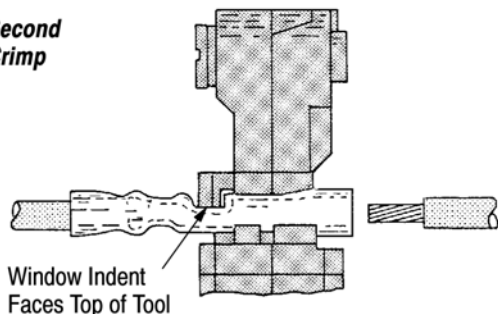
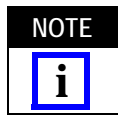

Figure 4

4.2. Spare Wire Caps

1. Strip wire to dimensions listed in Figure 2. Crimp the color coded portion of the tool. Refer to Section 3.



Do not use wire with nicked or missing conductor strands.

2. Place tool insulation adjustment indicator in Position 4.
3. Close tool handles until crimping jaws partially close, but leave enough space for cap to be inserted between dies.
4. Raise locator so that end of cap rests against the recessed surface of the locator as shown in Figure 5.

Spare Wire Caps

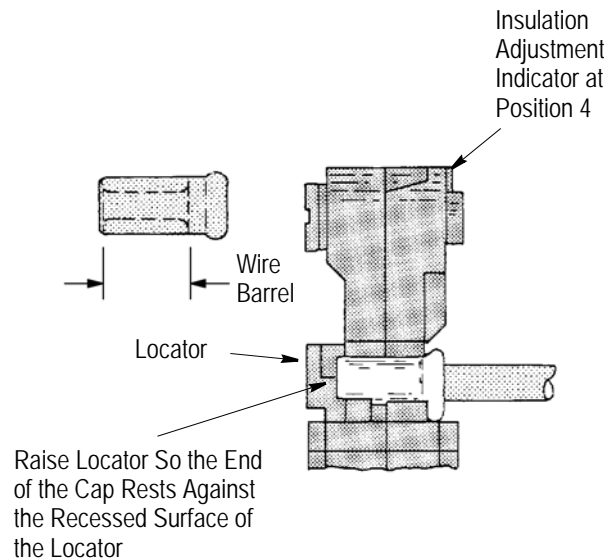

Figure 5

5. Squeeze quick take-up trigger and close handles until cap is held firmly in place. Do not deform cap wire barrel.
6. Insert stripped wire into cap until conductor bottoms in cap.
7. Hold wire in position and complete crimp by closing handles until the ratchet releases. Handles will open automatically and crimped cap may be removed.
8. Refer to Section 6 and Figure 7 wire cap crimp inspection procedure.

NOTE Depending on the color and material of the crimped terminal, the dot codes may be difficult to see. Be sure to use good lighting and high magnification when looking for the dot codes.

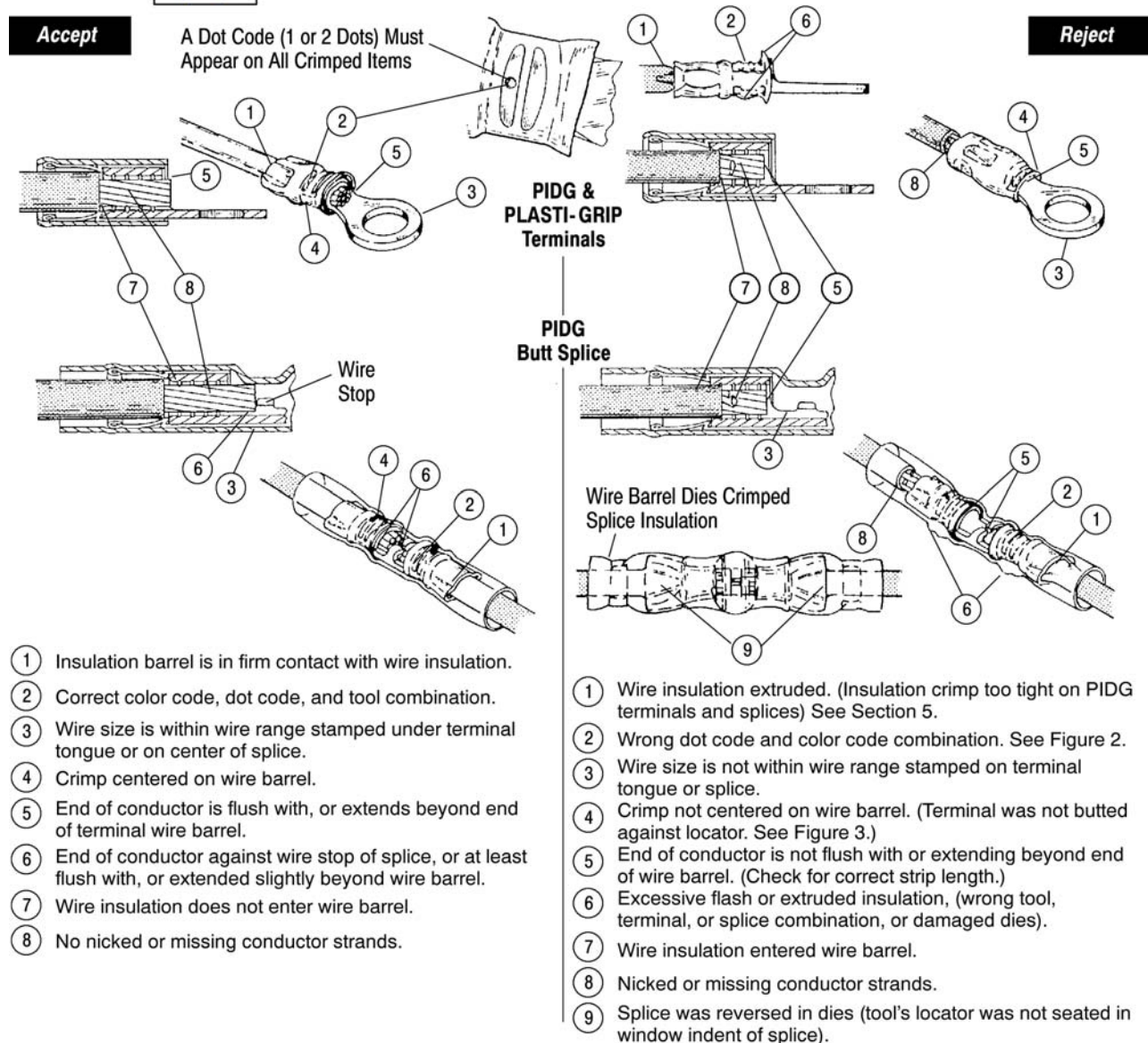

Figure 6

5. INSULATION CRIMP ADJUSTMENT

5.1. PIDG Terminals and Splices

NOTE PIDG terminals and splices feature a wire "insulation grip".

Each tool has four insulation crimp positions. See Figure 1.

1. Loosen insulation adjustment locking screw (see top of tool) and turn indicator to Position 4.

2. Place terminal or splice in tool dies.

3. Insert UNSTRIPPED wire into ONLY the insulation barrel (see Figure 3 or Figure 4) of terminal or splice.

4. Perform a crimp (Section 4). Remove crimped terminal or splice and check insulation grip as follows: Bend the wire back and forth once. Terminal or splice should retain grip on wire insulation.

5. If wire pulls out, set insulation adjustment indicator to next tighter position - Position 3.

NOTE

Depending on the color and material of the crimped terminal, the dot codes may be difficult to see. Be sure to use good lighting and high magnification when looking for the dot codes.

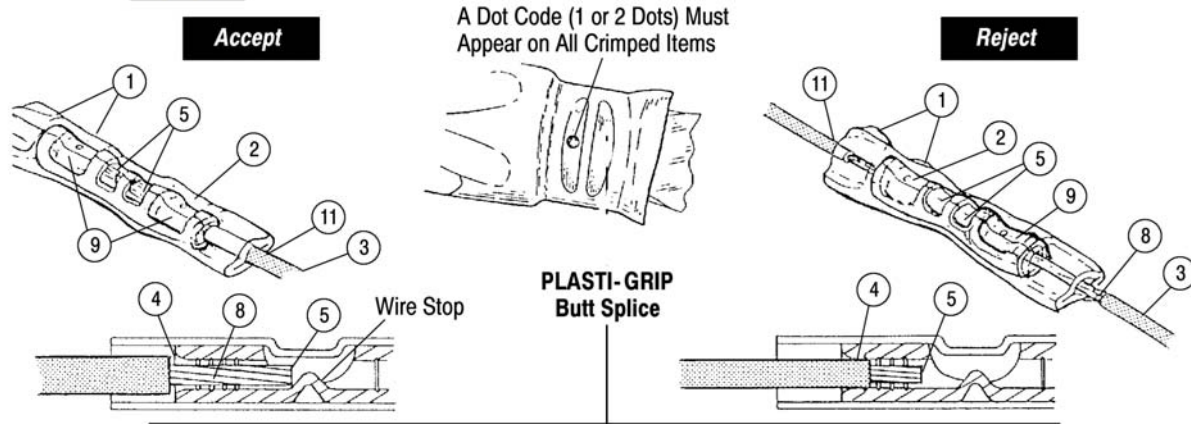

- Accept**
- Reject**
- PLASTI-GRIP Butt Splice**
- Spare Wire Cap**
- 1 No flash or extruded insulation.
 - 2 Correct color code, dot code, and tool combination. Dot coding disappears on sealed splices when they are heat sealed.
 - 3 Correct wire size used.
 - 4 Wire insulation does not enter wire barrel of splice.
 - 5 End of conductor against wire stop of splice, or at least flush with, or extended slightly beyond wire barrel.
 - 6 End of conductor bottomed in cap.
 - 7 Full width of crimp is over wire barrel.
 - 8 No nicked or missing conductor strands.
 - 9 Crimp centered on wire barrel.
 - 10 Splice insulation is in contact with wire insulation.
- 1 Excessive flash or extended insulation. (Crimped in smaller dies on wrong side of tool.) Also, check for damaged dies.
 - 2 Wrong dot code and color code combination. See Figure 2.
 - 3 Incorrect wire size used.
 - 4 Wire insulation entered wire barrel.
 - 5 End of conductor is not flush with or extending beyond end of wire barrel. (Check strip length.)
 - 6 End of conductor not bottomed in cap.
 - 7 Half of crimp off end of wire barrel (Cap was not bottomed in recess of locator.)
 - 8 Nicked or missing conductor strands.
 - 9 Crimp not centered on wire barrel. (Tool locator not seated in window indent.)
 - 10 Splice insulation is not in contact with wire insulation.

Figure 7

6. Perform a crimp and repeat adjustment as necessary until desired insulation grip is obtained. Do not use a tighter setting than required.

7. Tighten insulation adjustment locking screw (see top of tool).

5.2. PLASTI-GRIP Terminals and Splices

NOTE

PLASTI-GRIP terminals and splices feature a wire "insulation support" only.

1. Set insulation adjustment indicator in Position 4 for wire having a large insulation diameter.

2. Set insulation adjustment indicator in Position 3 for wire having a medium insulation diameter.

3. Set insulation adjustment indicator in Position 2 for wire having a small insulation diameter.

4. Set insulation adjustment indicator in Position 1 for wire having thin wall insulation. Terminal or splice insulation should ideally be in contact with wire insulation.

6. CRIMP INSPECTION

Inspect crimped terminals, splices and spare wire caps by checking the features described in Figure 6 or Figure 7.

Use only the crimped items that meet the conditions shown in the ACCEPT column.

REJECT terminals, splices, and spare wire caps can be avoided through careful use of instructions and by performing regular tool maintenance as instructed in this document.

NOTE  *Locators in Crimping Tools 69692-1 and 69693-1 are locked in the down position. Refer to Instruction Sheet 408-7424 for crimp height inspection of these tools.*

7. MAINTENANCE AND INSPECTION

TE recommends that a maintenance/inspection program be performed periodically to ensure dependable and uniform terminations. Tools should be inspected at least once a month. Frequency of inspection may be adjusted to suit your requirements through experience. Frequency of inspection is dependent upon:

1. The care, amount of use, and handling of the tool.
2. The type and size of the products crimped.
3. The degree of operator skill.
4. The presence of abnormal amounts of dust and dirt.
5. Your own established standards.

All tools are inspected before packaging. Since there is a possibility of tool damage in shipment, new tools should be inspected in accordance with Section 7 when received in your plant. Due to the precision design, it is important that no parts of these tools be interchanged except those replacement parts listed in Figure 13.

7.1. Cleaning

The tool should be immersed (handles partially closed) in degreasing compound to remove accumulated dirt, grease, and foreign matter.

NOTE  *Make certain the degreasing compound does not attack paint or plastic materials.*

Remove remaining degreasing compound with a lint free cloth. When degreasing compounds are not available, tool may be wiped clean with a lint free cloth. Relubricate tool, as instructed in Paragraph 7.3 before placing it back in service.

7.2. Visual Inspection

1. Visually inspect the tool for missing parts, then operate the tool and note the return action of the spring-loaded handles. If parts are missing or defective, refer to Figure 13 for customer replaceable parts.

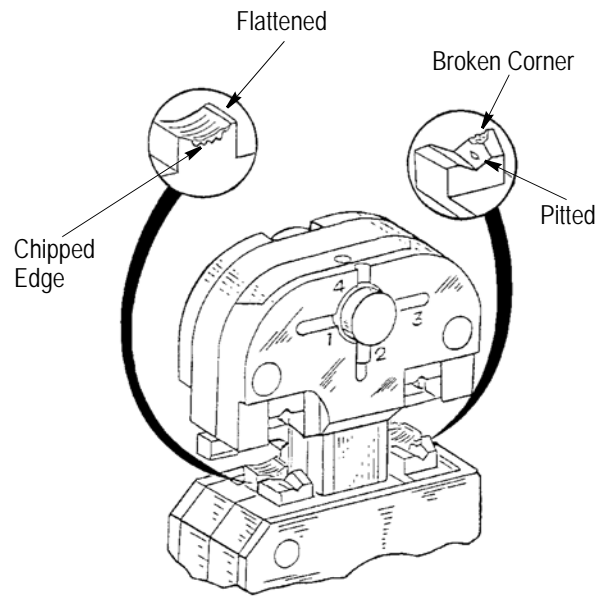

Figure 8

2. Visually inspect the die closure surfaces for flattened, broken, pitted, or chipped conditions. Although dies may gage within permissible limits, worn or damaged die closure surfaces are objectionable and can affect the quality of the crimp. Examples of possible damaged die closure surfaces are shown in Figure 8.

7.3. Lubrication

Lubricate all pins, pivot points, and bearing surfaces with SAE 20 motor oil as follows:

- Tools used in daily production-Lubricate daily
- Tools used daily (occasional)-Lubricate weekly
- Tools used weekly-Lubricate monthly

Wipe excess oil from tool, particularly from crimping area. Oil transferred from the crimping area onto certain terminations may affect the electrical characteristics of an application.

7.4. Gaging the Crimping Chamber

Each tool is inspected for proper die closures before packaging. An inspection should be performed periodically to check the tool die closures for excessive wear.

NOTE  *The following plug gaging information for insulation crimping chambers is provided for customers specifically requiring this information. If plug gaging is not required, inspect the die closures using an alternate procedure, i.e., performing the "Insulation Crimp Adjustment" (see Section 5) and "Visual Inspection" (see Paragraph 7.2).*

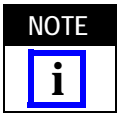

Refer to the table in Figure 11 for alternate hard gage dimensions for tools 69692-1 and 69693-1.

A. Gaging the Crimping Chamber Using A Plug Gage

This inspection requires the use of plug gages conforming to the dimensions listed in Figure 9 and Figure 10. Tyco Electronics does not manufacture or market these gages. Refer to 408-7424 for information concerning plug gages

To gage the crimping area(s), refer to Figure 12 and proceed as follows:

1. Clean oil or dirt from the crimping chamber and plug gage.
2. Close handles of tool until wire barrel dies are bottomed. Do not apply additional pressure to tool handles.
3. With wire barrel dies bottomed, inspect the wire barrel crimping chamber using the proper plug gage. Lift the spring-loaded locator up and hold gage in straight alignment with the crimping

chamber. Carefully try to insert, without forcing, the GO element. See Figure 12, Detail A. The GO element must pass completely through the crimping area.

4. Try to insert the NO-GO element. The NO-GO element may enter partially, but must not pass completely through the crimping area.
5. Set insulation adjustment indicator in Position 1. Measure both insulation crimping chambers with the proper GO plug gages in the same manner as Steps 2 and 3. See Figure 12, Detail B.
6. Set insulation adjustment indicator in Position 4. Measure both insulation crimping chambers with the proper NO-GO plug gages in the same manner as Steps 2 and 4. See Figure 12, Detail B.

If the crimping areas conform to the gage inspection, the tool is considered dimensionally correct. If the crimping areas do not conform to the inspection, the tool must be repaired. Refer to Section 8, REPLACEMENT AND REPAIR.

Suggested Plug Gage Design - Wire Barrel Crimping Chamber

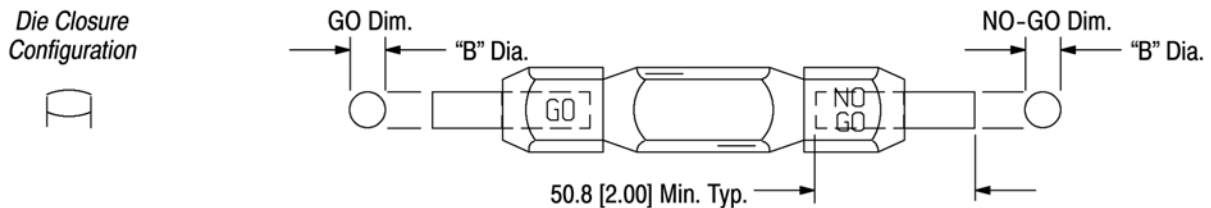

TOOL NUMBER	WIRE SIZE AWG	GAGE ELEMENT DIMENSION "B"	
		GO	NO-GO
59170 and 59250	22 - 16	2.769 - 2.776 [.1090 - .1093]	2.918 - 2.921 [.1149 - .1150]
	16 - 14	3.023 - 3.030 [.1190 - .1193]	3.172 - 3.175 [.1249 - .1250]
59275	26 - 22	1.600 - 1.608 [.0630 - .0633]	1.750 - 1.753 [.0689 - .0690]
	24 - 20	2.261 - 2.268 [.0890 - .0893]	2.410 - 2.413 [.0949 - .0950]
59300	24 - 20	2.261 - 2.268 [.0890 - .0893]	2.410 - 2.413 [.0949 - .0950]
	22 - 16	2.769 - 2.776 [.1090 - .1093]	2.918 - 2.921 [.1149 - .1150]

Use solder slug and crimp height comparator. (Reference 408-7424)

TOOL NUMBER	WIRE SIZE AWG	SOLDER SLUG CRIMP HEIGHT	SOLDER SLUG DIAMETER REFERENCE
69692-1	26 - 24	2.34 ± 0.05 [.092 ± .002]	1/8 Diameter
	22 - 20	2.69 ± 0.05 [.106 ± .002]	1/8 Diameter
69693-1	18 - 16	3.35 ± 0.05 [.132 ± .002]	#18 - 1/8 Dia. #16 - 3/16 Dia.
	14	3.86 ± 0.05 [.152 ± .002]	3/16 Diameter

Figure 9

B. Gaging the Crimping Chamber Using A Solder Slug and Crimp Height Comparator

This inspection requires the use of crimp height comparators, solder slugs, and the dimensions listed in Figure 10. Tyco Electronics does not manufacture or market crimp-height comparators. Refer to 408-7424 for information concerning comparators.

To gage the crimping chamber using the solder slug, proceed as follows:

1. Clean oil or dirt from the crimping chamber.
2. Set insulation adjustment to the number 1 position.
3. Insert proper solder slug into one crimp chamber (see Figure 9 and Figure 10) and cycle tool.

4. Measure the compressed solder slug for the wire-barrel crimping chamber and check for compliance to dimensions in Figure 9.

5. Measure the compressed area for the insulation-crimping chamber and check for compliance to the GO dimensions in Figure 10.

6. Set the insulation adjustment to the number 4 position and insert the appropriate solder slug into the insulation chamber.

7. Cycle the tool.

8. Measure the compressed area (of the solder) for the insulation-crimping chamber and check for compliance to the NO-GO dimensions in Figure 10.

9. Repeat the steps above for the second crimp chamber.

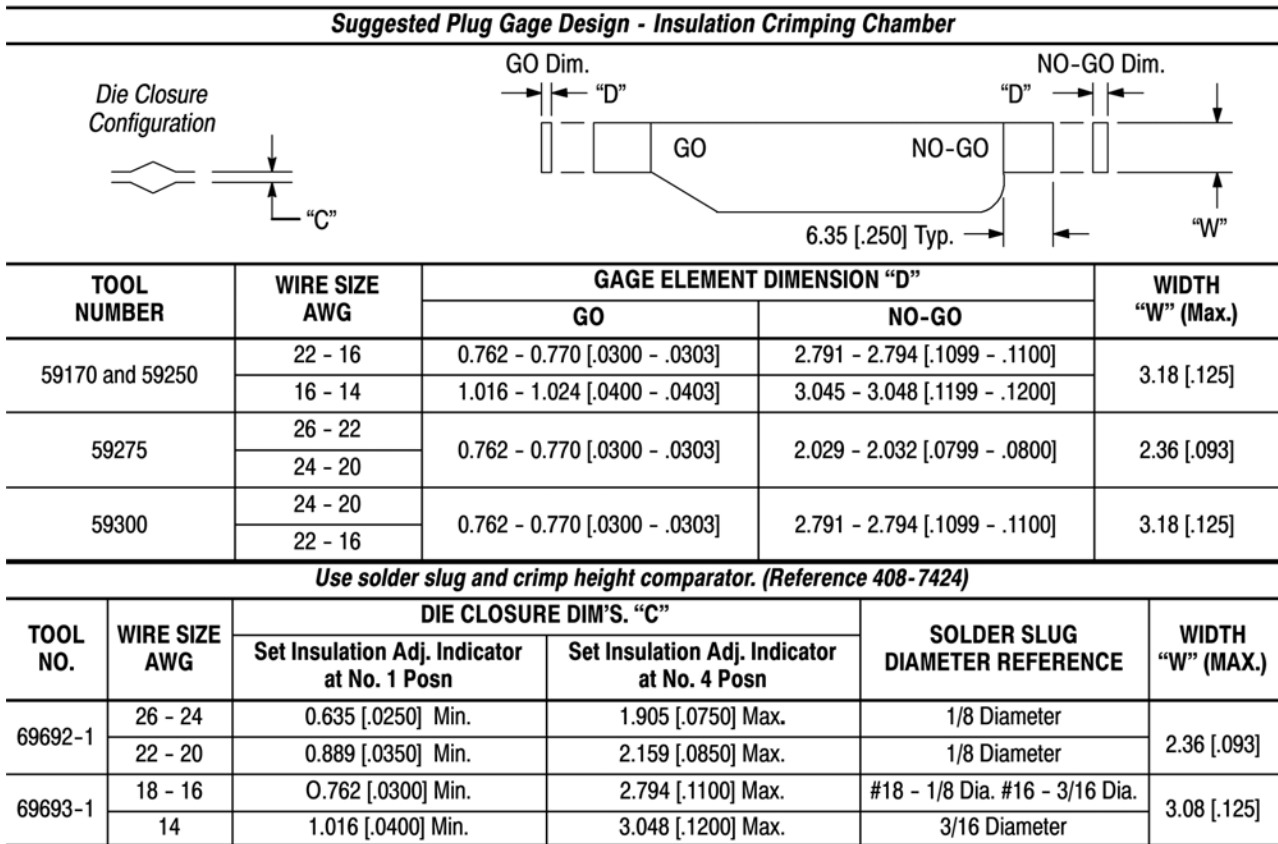

Figure 10

Suggested Plug Gage Design for Tools 69692-1 and 69693-1 - Insulation Crimping Chamber

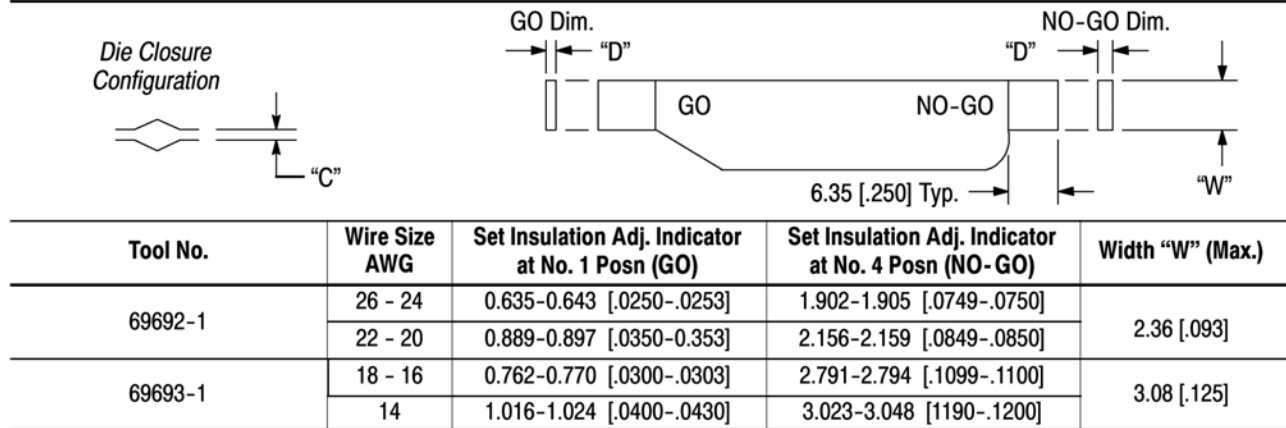

Figure 11

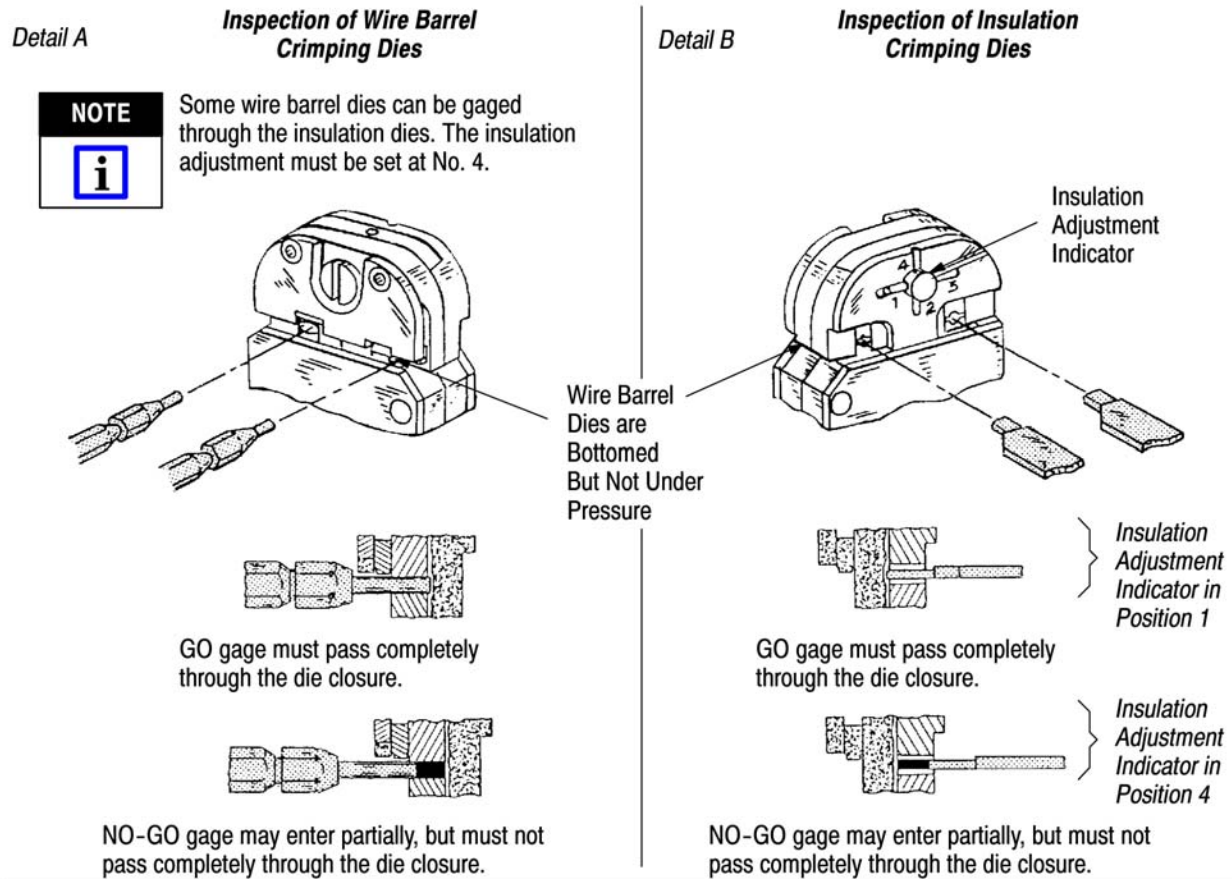

Figure 12

7.5. Ratchet Control Inspection

Obtain a .025-mm [.001-in.] shim that is suitable for checking the clearance between the bottoming surfaces of the crimping dies. To inspect the CERTI-CRIMP hand crimping tool ratchet control:

1. Perform a crimp using the largest wire size for your tool.
2. While holding the wire in place, squeeze the tool handles together until the ratchet releases. Hold the tool in this position, maintaining just enough pressure to keep the dies closed.

3. Check the clearance between the bottoming surfaces of the crimping dies. If the clearance is .025 mm [.001 in.] or less, the ratchet is satisfactory. If clearance exceeds .025 mm [.001 in.], the ratchet is out of adjustment, and must be repaired. Refer to Section 8, REPLACEMENT AND REPAIR. If the tool conforms to these inspection procedures, lubricate it with a THIN coat of any good SAE# 20 motor oil and return it to service.

8. REPLACEMENT AND REPAIR

Replacement parts are listed in Figure 13. Parts other than those listed in Figure 13 should be replaced by Tyco Electronics to ensure quality and reliability of the tool. Order replacement parts through your TE

Representative, or call 1-800-526-5142, or send a facsimile of your purchase order to 1-717-986-7605, or write to:

CUSTOMER SERVICE (038-035)
 TYCO ELECTRONICS CORPORATION
 PO BOX 3608
 HARRISBURG PA 17105-3608

9. REVISION SUMMARY

Since the previous release of this sheet, the new company logo was applied.

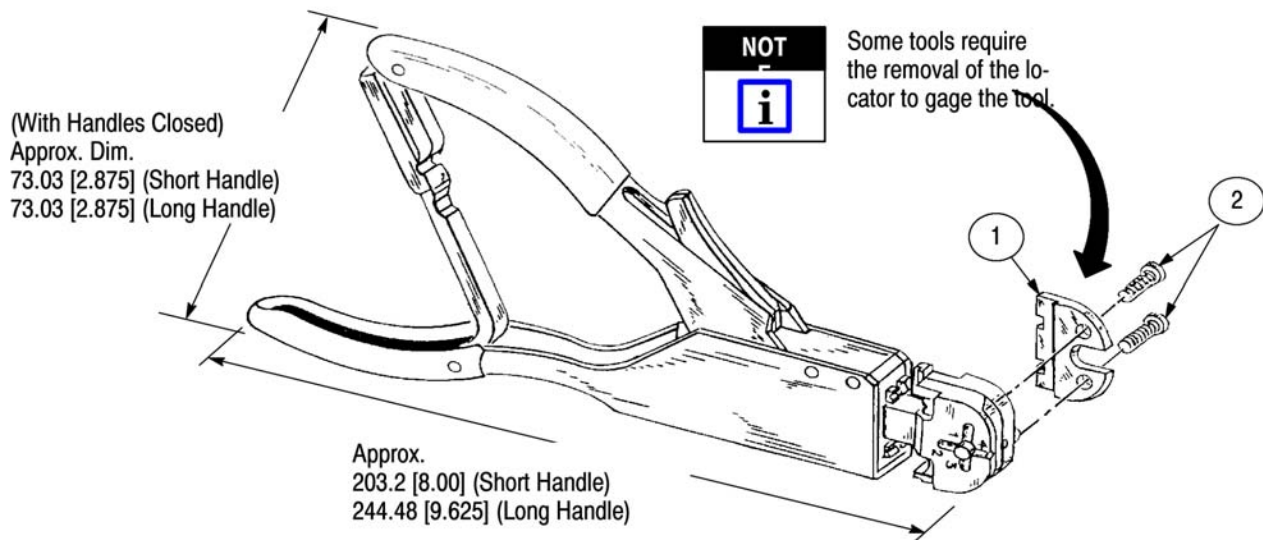

TOOL NUMBERS AND REPLACEMENT PART NUMBER

ITEM	DESCRIPTION	591 SHORT HANDLE 59250 LONG HANDLE	59275 SHORT HANDLE 59300 LONG HANDLE	69692-1 LONG HANDLE	69693-1 LONG HANDLE	QTY PER ASSY
1	Support, Locator	---	---	59755-1	59755-2	1
2	Screw	---	---	1-21002-3	1-21002-3	2

Figure 13