

Figure 1

## 1. INTRODUCTION

This instruction sheet covers the application and maintenance procedures for Pneumatic Crimping Head Assembly 314991-1. The crimping head assembly is designed for use in Pneumatic Tool 69015 to crimp AMPLI-BOND and PLASTI-GRIP terminals on stranded copper wire size 4 AWG.

For further information concerning setup procedures, refer to instruction sheet 408-1310, which is packaged with the pneumatic tool. For additional information on AMPLI-BOND and PLASTI-GRIP terminals, refer to Tyco Electronics Catalogs 82038 and 82042.

Reasons for reissue are listed Section 8, REVISION SUMMARY.

Read these instructions thoroughly before crimping any terminals.

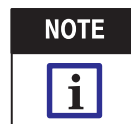

*Dimensions on this sheet are in metric units [with U.S. customary units in brackets]. Figures and illustrations are for identification only and are not drawn to scale.*

## 2. DESCRIPTION

The crimping head assembly features two crimping areas, each marked on the front side of the head to show the wire size. The integral jaws (indenter and anvil) close in an arc-like motion. The assembly includes two toggle links, two links, and one toggle lever. See Figure 1.

Terminals and heads are color coded as listed in Figure 2. Dies have the terminal size stamped on the wire barrel crimp sections of dies.

When crimped, the wire size will appear on both sides of the terminal wire barrel. The wire size appearing on the crimped wire barrel should always agree with the wire size stamped on the terminal tongue.

**3. HEAD INSTALLATION AND REMOVAL**

**NOTE**  
 Crimping heads are coated with a preservative to prevent rust and corrosion. Wipe this preservative from the crimping head, particularly from the crimping surfaces.

**3.1. Installation**

**DANGER**  
 To avoid personal injury, ALWAYS disconnect pneumatic tool from air supply before installing the crimping head.

**DANGER**  
 Do NOT operate tool without having crimping head installed and lockscrew tightened.

1. Remove assembly pins from mounting lugs as shown in Figure 1.
2. Pull toggle arm forward and insert toggle lever of crimping head all the way into hole in toggle arm until it snaps in place. See Figure 1.
3. Align holes in crimping head links with holes in mounting lugs.
4. Insert assembly pins.

**CAUTION**  
 Be sure assembly pins are fully inserted or damage to tool or pins will occur.

5. Connect pneumatic tool to an adequate air supply between 585–690 kPa [85–100 psi]. For specific information on air line requirements and air hose installation, refer to the customer manual packaged with the pneumatic tooling assembly.
6. Tool is now ready for operation.

**3.2. Removal**

**DANGER**  
 To avoid personal injury, ALWAYS disconnect pneumatic tool from air supply before removing the crimping head.

1. Remove assembly pins.
2. Lower head away from mounting lugs, twist head 90°, and remove from toggle arm.
3. Re-install assembly pins.

**4. CRIMPING PROCEDURE**

Strip the wire using the appropriate strip-length dimension provided in Figure 2. Do NOT nick or cut the wire strands. Proceed as follows:

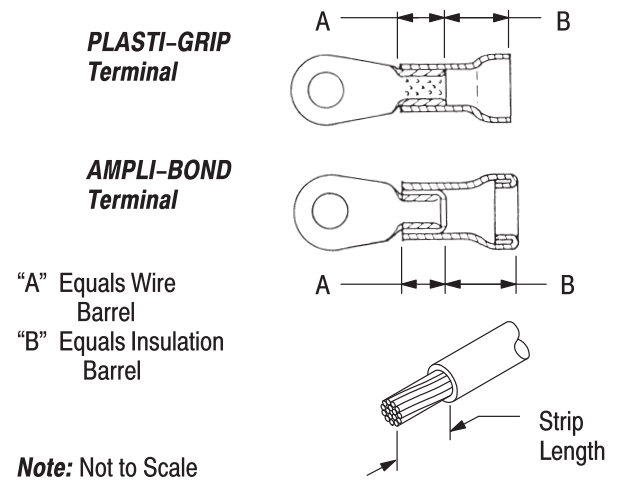

WIRE		TERMINAL AND HEAD COLOR CODE	WIRE STRIP LENGTH	
SIZE (AWG)	INSUL DIA (Max)		MIN	MAX
4	11.07 [.436]	YELLOW	11.51 [.453]	12.29 [.484]

Figure 2

1. Check that wire size stamped on terminal corresponds with the wire size stamped on the crimping head link.
2. Place terminal in dies. See Figure 3. Bottom of terminal tongue should face top of tool and terminal barrel should rest against locator.
3. Insert stripped wire in terminal until end of wire conductor butts against locator as shown in Figure 3.

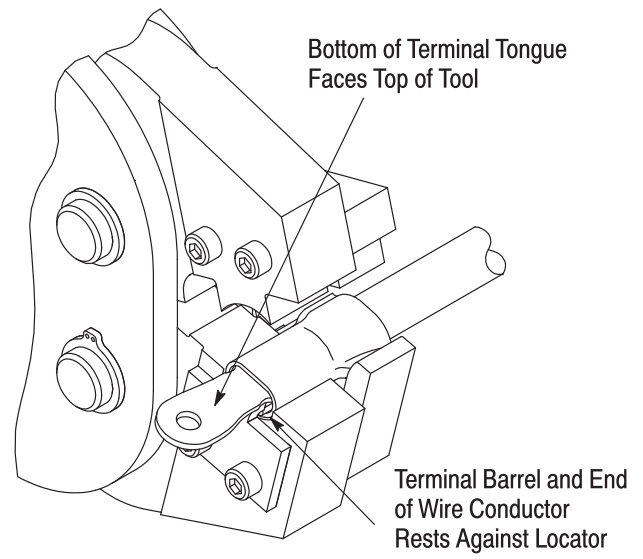

Figure 3

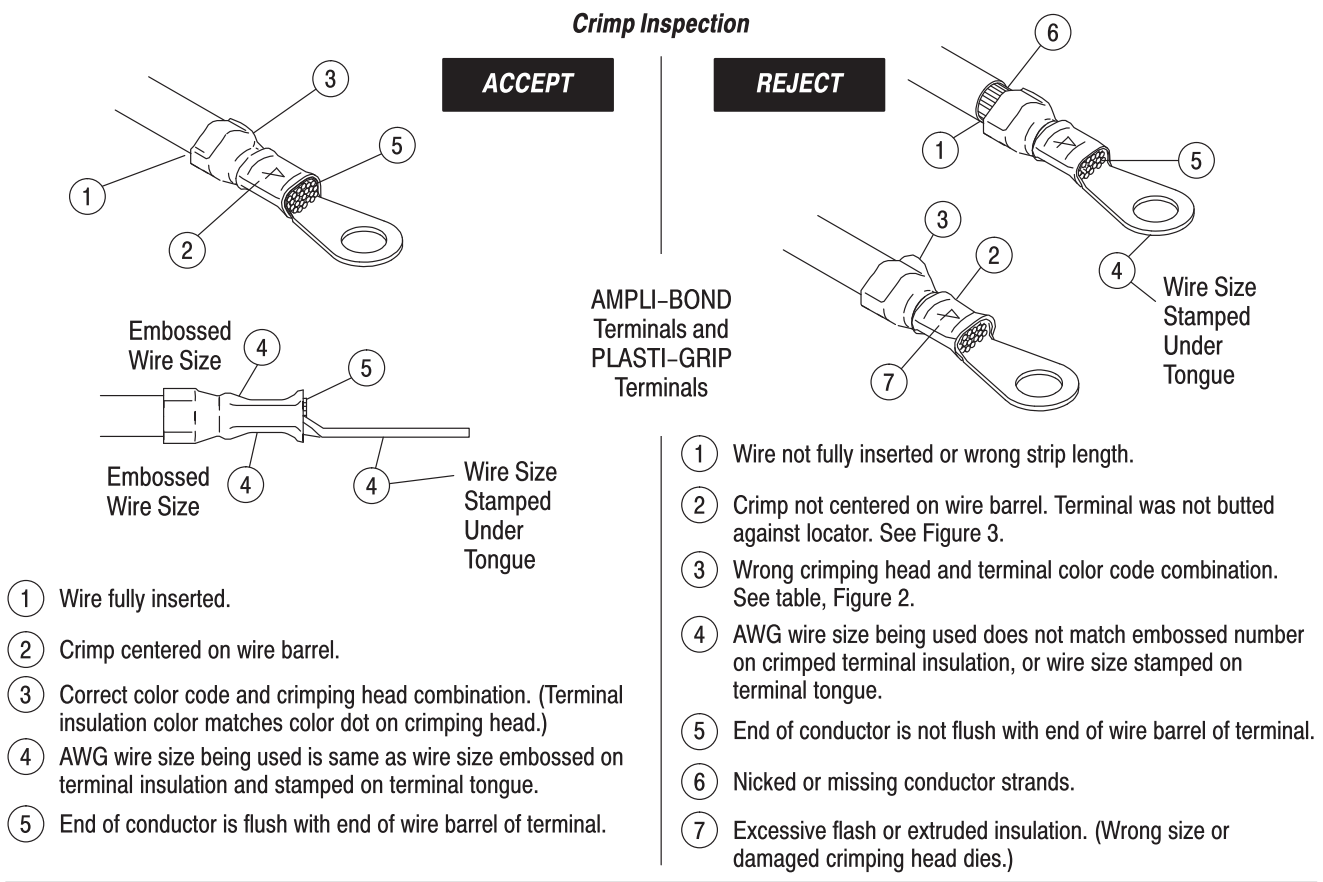

Figure 4

4. Hold terminal in place and press thumb control and hold it down until crimping stroke is completed.

5. Release thumb control and remove crimped terminal.

6. Refer to Section 5 and Figure 4 for crimp inspection procedure.

**NOTE**

**i** *AMPLI-BOND terminals contain a wire insulation "grip" and PLASTI-GRIP terminals contain a wire insulation "support." Terminal insulation will not always touch wire insulation, but will provide "support" when wire is flexed.*

**5. CRIMP INSPECTION**

Inspect crimped terminals by checking the features described in Figure 4. Use only terminals that meet the conditions shown in the "ACCEPT" column. "REJECT" terminations can be avoided through careful use of instruction in Section 4, and by performing regular head maintenance, as described in Section 6.

**6. MAINTENANCE AND INSPECTION**

**DANGER**

**STOP** *To avoid personal injury, ALWAYS disconnect air supply from pneumatic tool before performing maintenance or inspection.*

Tyco Electronics recommends that a maintenance and inspection program be performed periodically to ensure dependable and uniform terminations. The pneumatic crimping head should be inspected once a month. Frequency of inspection should be adjusted to suit your requirements through experience. Frequency of inspection depends on:

1. The care, amount of use, and handling of the crimping head.
2. The type and size of the product crimped.
3. The degree of operator skill.
4. The presence of abnormal amounts of dust and dirt.
5. Your own established standards.

Each crimping head is thoroughly inspected before packaging. Since there is the possibility of damage during shipment, new crimping heads should be inspected immediately upon arrival at your facility.

## 6.1. Daily Maintenance

Tyco Electronics recommends that each operator be responsible for the following steps of daily maintenance:

1. Remove dust, moisture, and other contaminants with a clean, soft brush, or a lint-free cloth. Do NOT use objects that could damage the head.
2. Make sure that all pins, rings, and other components are in place and secure.



*Do not remove the retaining pins as permanent damage to the tool could result.*

3. Make certain all surfaces are protected with a thin coat of any good SAE 20 motor oil. Do NOT oil excessively.
4. When the crimping head is not in use, store it in a clean, dry area.

## 6.2. Periodic Inspection

Regular inspections should be performed by quality control personnel. A record of scheduled inspections should remain with the crimping head or be supplied to supervisory personnel responsible for the crimping head. Though recommendations call for at least one inspection a month, the frequency should be based on amount of use, working conditions, operator training and skill, and your established company policies. These inspections should include a visual inspection (Paragraph 6.3) and a crimping chamber inspection (Paragraph 6.5).

## 6.3. Visual Inspection

1. Remove all lubrication and accumulated film by immersing the crimping head in a suitable commercial degreaser that will not affect paint or plastic.
2. Make certain all components are in place. If replacements are necessary, refer to Figure 8.
3. Inspect crimp area for flattened, chipped, or broken areas. See Figure 5. Replace worn or damaged parts.

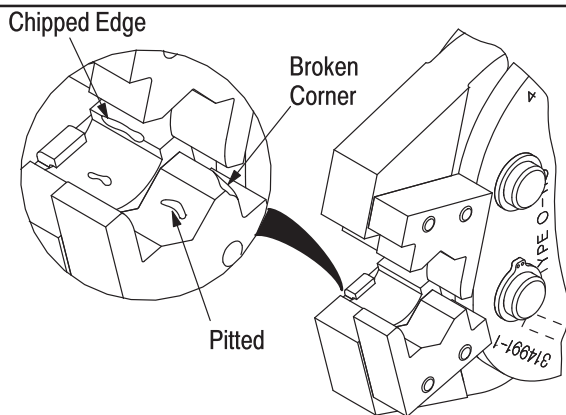

Figure 5

## 6.4. Lubrication

Lubricate all pins, pivot points, and bearing surfaces with a high quality grease. Tyco Electronics recommends the use of Molykote<sup>‡</sup> grease, which is a commercially available lubricant. Lubricate according to the following schedule:

- Head used in daily production – lubricate daily
- Head used daily (occasional) – lubricate weekly
- Head used weekly – lubricate monthly

Wipe excess grease from crimping head, particularly from jaw closure areas. Grease transferred from jaw closure area onto certain terminations may affect the electrical characteristics of an application.

## 6.5. Gaging the Crimping Chamber

This inspection requires the use of plug gages conforming to the dimensions shown in Figure 6. Tyco Electronics does not manufacture or market these gages.



*Disconnect air supply and remove crimping head from pneumatic tool before inspecting crimping chamber.*

1. Remove oil and dirt from the bottom of the jaw surfaces and plug gage element surfaces.
2. Close wire barrel crimping jaws until they are bottomed, but not under pressure.
3. Remove locator from the head.
4. Align GO element with wire barrel crimping section. Push element straight into crimping chamber without using force. The GO element must pass completely through the crimping chamber as shown in Figure 7, Detail A.
5. Align the NO-GO element and try to insert it into the crimping chamber. The element may start entry, but it must not pass completely through the crimping chamber.
6. Replace locator.
7. Repeat this procedure for the insulation crimping section using a plug gage as shown in Figure 7, Detail B.

If the crimping chamber passes the gage inspection, the crimping head is considered dimensionally correct and should be lubricated with a THIN coat of any good SAE 20 motor oil. If the crimping chamber does not conform to the plug gage conditions, contact your local Tyco Electronics Field Representative or refer to Section 7, REPLACEMENT AND REPAIR.

<sup>‡</sup> Trademark of Dow Corning Corporation

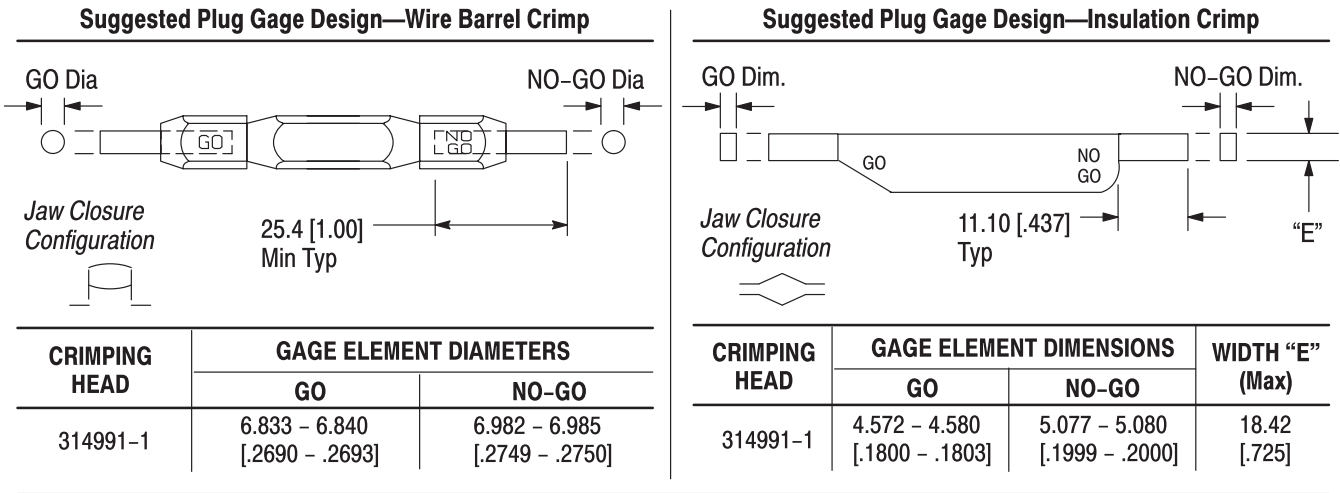

Figure 6

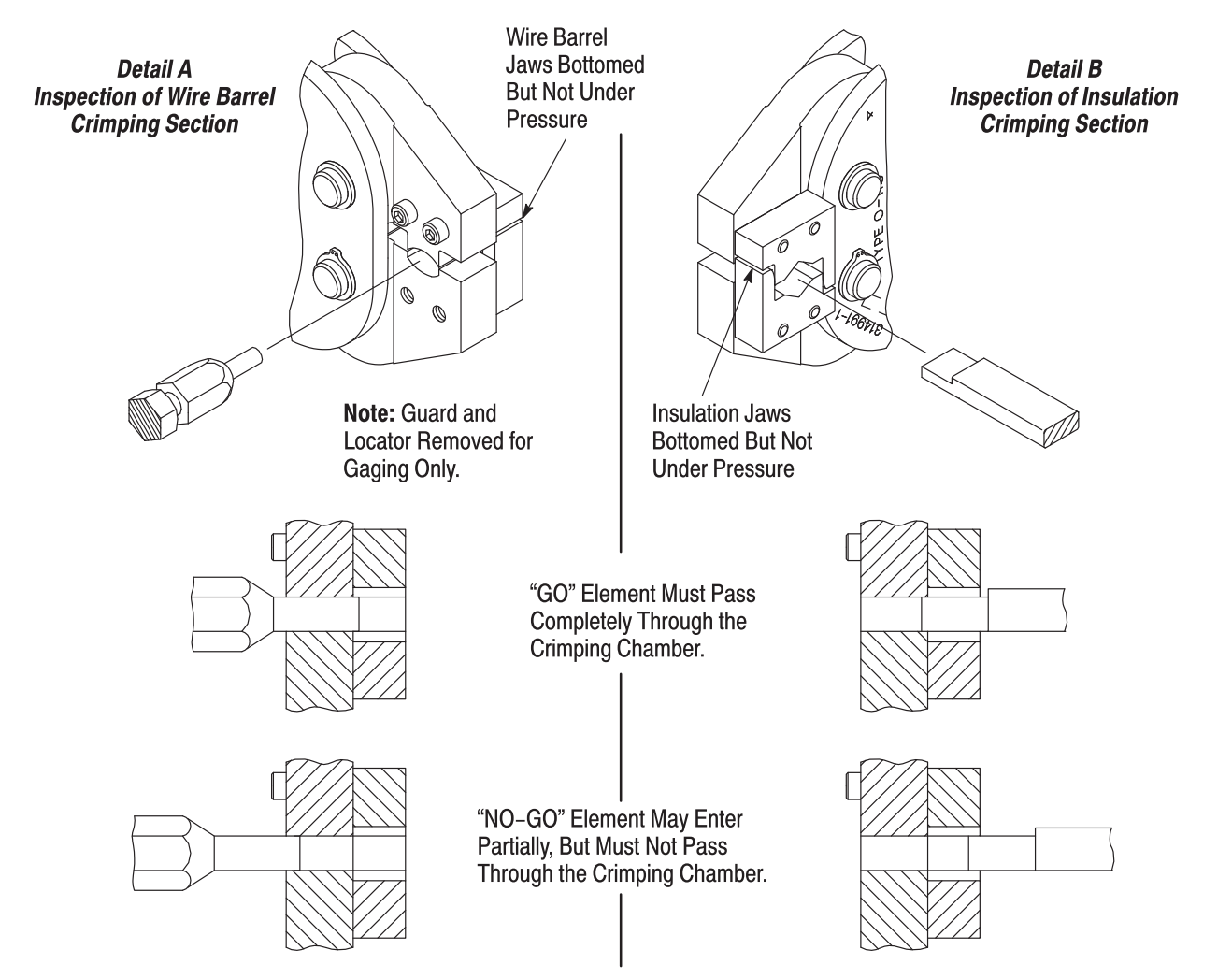

Figure 7

For additional information about the use of a plug gage, see Instruction Sheet 408-7424.

**7. REPLACEMENT AND REPAIR**

Replacement parts and recommended spares are listed in Figure 8. The recommended spares should be stocked for immediate replacement.

Order replacement parts through your Tyco Electronics representative, or call 1-800-526-5142, or send a facsimile of your purchase order to 1-717-986-7605, or write to:

CUSTOMER SERVICE (38-35)  
 TYCO ELECTRONICS CORPORATION  
 P.O. BOX 3608  
 HARRISBURG, PA 17105-3608

For further repair and replacement information, call the Tyco Electronics Technical Assistance Center: 1-800-722-1111.

For customer repair service, call 1-800-526-5136.

**8. REVISION SUMMARY**

Revisions to this instruction sheet include:

- Updated document to corporate requirements.
- Replaced customer repair contact address with telephone contact.
- Changed orientation of Figure 6 to aid text flow in document.

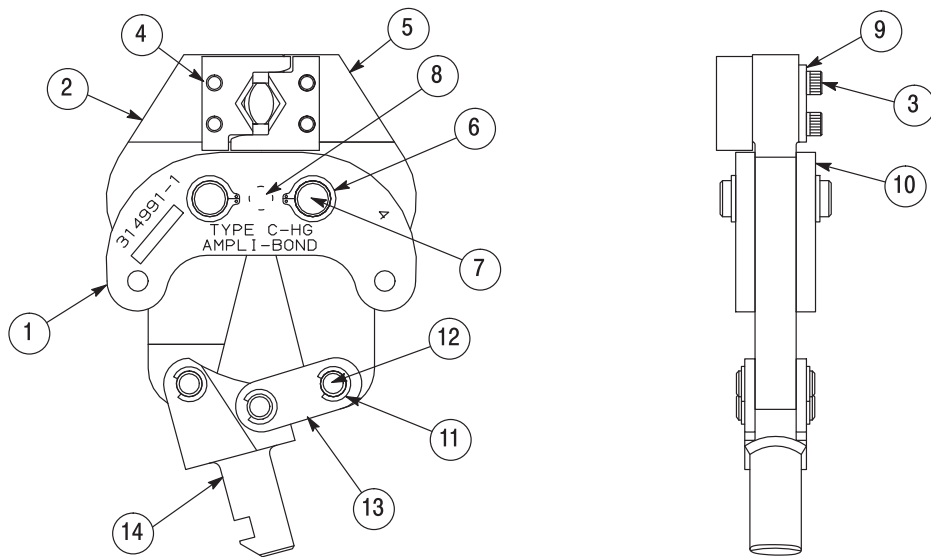

**CUSTOMER REPLACEMENT PARTS**

ITEM	PART NUMBER	DESCRIPTION	QTY PER HEAD
1	300110	LINK	1
2	314994-1	INDENTER	1
3	3-21000-9■	SCREW, SHC 10-32 x 1.000	4
4	314996-1	INSERT, Insulation	2
5	314995-1	ANVIL	1
6	1-21048-6■	RING, Retaining	4
7	300042■	PIN, Retaining	2
8	300115■	PIN, Pivot	1
9	308857-1	LOCATOR	1
10	300114	LINK	1
11	21045-8■	RING, Retaining	6
12	302563■	PIN, Retaining	3
13	302562	LINK, Toggle	2
14	302561	LEVER, Toggle	1

■ Recommended Spares

Figure 8