

PROPER USE GUIDELINES

Cumulative Trauma Disorders can result from the prolonged use of manually powered hand tools. Hand tools are intended for occasional use and low volume applications. A wide selection of powered application equipment for extended-use, production operations is available.

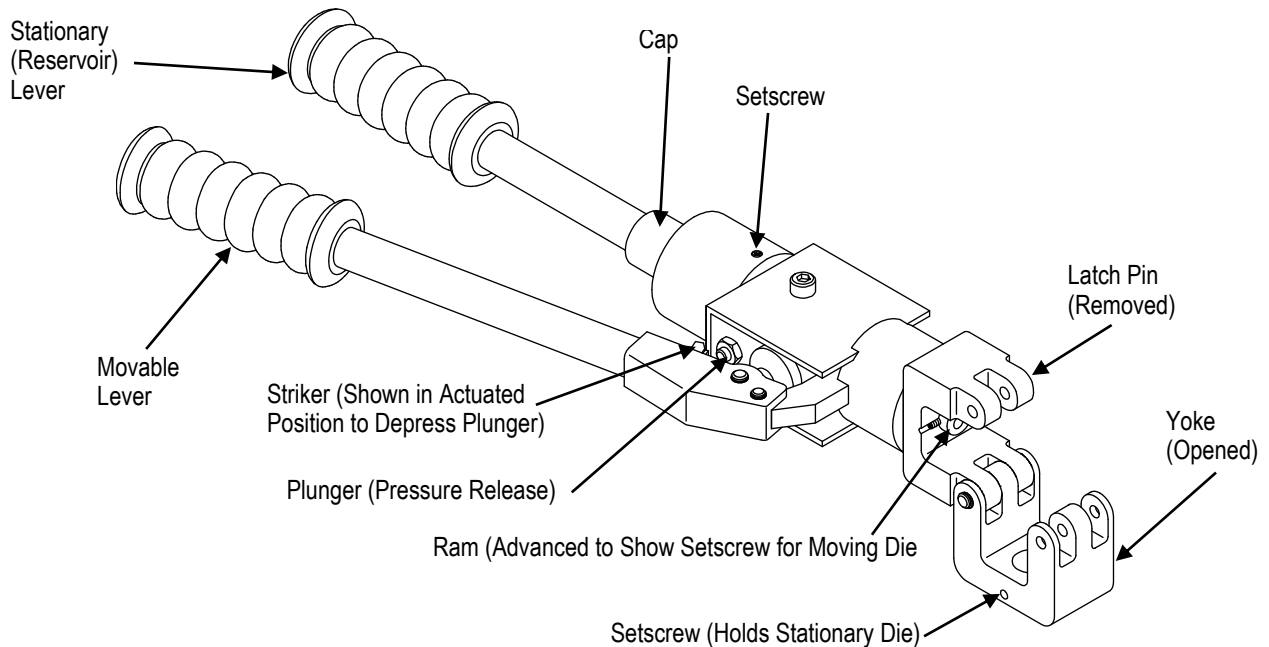

Wire Size (AWG)	Die Assembly (Applicable Instruction Sheet)		
	Ampli-Bond* Terminals and Splices (408-1758)	Terminyl* Terminals and Splices (408-1729)	Ampower* Pre-Insulated Terminals and Splices (408-1729)
8	48752-1 Mod. W	47820	---
6	48753-1 Mod. W	47821	---
4	48754-1 Mod. W	47822	---
2	48755-1 Mod. W	47823	47823

Figure 1

1. INTRODUCTION

Hydraulic Hand Tool PN 59974-1 is designed for crimping the terminals and splices listed in Figure 1.

i NOTE
Read these instructions thoroughly before using the hand tool.

i NOTE
Dimensions in this instruction sheet are in metric units [with U.S. customary units in brackets]. Figures and illustrations are for identification only and are not drawn to scale.

Reasons for reissue of this instruction sheet are provided in Section 7, REVISION SUMMARY.

2. DESCRIPTION (Figure 1)

The hand tool has a stationary lever and a movable lever. These levers are compressed to pump hydraulic fluid behind the ram, moving it forward and thereby closing the dies. After the crimping is complete, the movable lever is turned to depress the plunger, and the moving die retracts to its original position, completing the crimping cycle.

3. DIE INSERTION AND REMOVAL

1. Pull out the latch pin and open the yoke (reference Figure 1).
2. Advance the ram slightly to gain access to the moving die setscrew.
Note that the stationary die is held in place by a setscrew.
3. Before inserting the dies, refer to the instruction sheet packaged with the dies for detailed instructions; insert or remove dies, as necessary, by following the procedures given in the instruction sheet.

4. CRIMPING PROCEDURE

1. Strip the wires to the dimensions specified in the instructions packaged with the dies (see Figure 1).
2. Insert the terminal or splice in the stationary die in accordance with the instruction sheet packaged with the dies.

**DANGER**

Ensure latch pin is fully inserted before operating hand tool.

3. Pump the movable lever until the moving die grips the terminal or splice.

**CAUTION**

Do not deform the wire barrel of the terminal or splice.

4. Insert the stripped wire into the wire barrel of the terminal or splice.
5. Continue pumping the moveable lever. There may be a slight audible 'click' indicating that the pump has shifted into the high-pressure stage.

Continue pumping the moveable lever. When the dies have bottomed, there will be an audible "pop". This indicates that the crimp is complete.

**CAUTION**

Potential damage to the tool may occur if the following Step 6 is not taken.

6. Retract movable die by opening the movable handle to the full open position. Turn the movable handle (to actuate striker), **DO NOT TURN THE MOVABLE HANDLE WHILE IN THE CLOSED POSITION AS YOU WILL DAMAGE THE PLUNGER (PRESSURE RELEASE)**, and compress handles to depress plunger (pressure release).

Movable die will now retract.

7. Remove the latch pin, open the yoke, and remove the crimped terminal or splice.

**NOTE**

If the terminal or splice sticks in the die after crimping, apply a rocking action to remove it from the die.

8. Inspect the crimped terminal or splice in accordance with the inspection procedure in the instruction sheet packaged with the dies.

5. INSPECTION AND MAINTENANCE

**DANGER**

Make sure hydraulic pressure is released before following maintenance and inspection procedures, unless otherwise specified in the procedure.

It is recommended that an inspection and maintenance program be performed periodically to ensure dependable and uniform terminations. Though recommendations call for at least one inspection per month, frequency of inspection depends on:

- ◆ The care, amount of use, and handling of the hand tool,
- ◆ The presence of abnormal amounts of dust and dirt,
- ◆ The degree of operator skill, and
- ◆ Your own established standards.

The hand tool is inspected before being shipped; however, it is recommended that the tool be inspected immediately upon arrival at your facility to ensure that the tool has not been damaged during shipment.

5.1. Visual Inspection

1. Verify that all retaining pins are in place and secured with retaining rings. If replacements are necessary, refer to parts listed in Figure 3.
2. Inspect head assembly for worn, cracked, or broken areas. If damage is evident, return the tool for evaluation and repair. See Section 6, REPLACEMENT AND REPAIR.



NOTE

Once per year, or every 7,500 cycles (whichever comes first), the hydraulic head should be returned to TE for magnetic particle inspection. Additionally, inspect and service the head every month or 1,000 cycles.

5.2. Daily Maintenance

1. Hand tool should be immersed (levers partially closed) in a reliable commercial degreasing compound to remove accumulated dirt, grease, and foreign matter. When degreasing compound is not available, tool may be wiped clean with a soft, lint-free cloth. DO NOT use hard or abrasive objects that could damage the tool.
2. Make certain that the retaining pins are in place and that they are secured with retaining rings.



CAUTION

Do not remove the retaining pins as permanent damage to the tool could result.

3. All pins, pivot points, and bearing surfaces should be protected with a THIN coat of any good SAE 20 motor oil. DO NOT oil excessively.
4. When the tool is not in use, keep levers closed to prevent objects from becoming lodged in the dies. Store the tool in a clean, dry area.

5.3. Crimping Pressure Inspection

Check the crimping pressure to ensure that dies are fully bottomed before pressure is reduced by the internal bypass valve. The inspection should be performed using each set of dies that will be used in the head.

1. Install the dies in accordance with Section 3, DIE INSERTION AND REMOVAL, and the instruction sheet packaged with the dies.
2. Select the wire and terminal or splice for the dies being used.
3. Place terminal or splice in the dies in accordance with the instruction sheet packaged with the dies.

Perform the crimping procedure as described in Section 4, CRIMPING PROCEDURE, Steps 3 thru 5. DO NOT release the hydraulic pressure at this time.

4. Check the clearance between bottoming surfaces of the crimping dies.
 - ◆ If clearance is 0.025 mm [.001 in.] or less, crimp pressure is satisfactory.
 - ◆ If clearance exceeds 0.025 mm [.001 in.], crimp pressure is considered NOT SATISFACTORY. See Section 6, REPLACEMENT AND REPAIR.

If the tool conforms to these inspection procedures, lubricate it with a THIN coat of any good SAE 20 motor oil and return it to service.

5.4. Lubrication

Keep all pins, pivot points, and bearing surfaces lubricated with SAE 20 motor oil as follows:

- ◆ Tool used in daily production: lubricate daily
- ◆ Tool used daily (occasionally): lubricate weekly
- ◆ Tool used weekly: lubricate monthly

Wipe excess oil from tool, particularly from crimping area.



CAUTION

Oil transferred from the crimping area onto certain terminations may affect the electrical characteristics of an application.

SAE is a trademark.

5.5. Hydraulic Fluid Level Inspection/Fill (Figure 2)

1. Turn the tool upside down and clamp it in a vise so that the tool levers are in an upright position.
2. Release all pressure in the tool in accordance with Step 6 of Section 4, CRIMPING PROCEDURE.

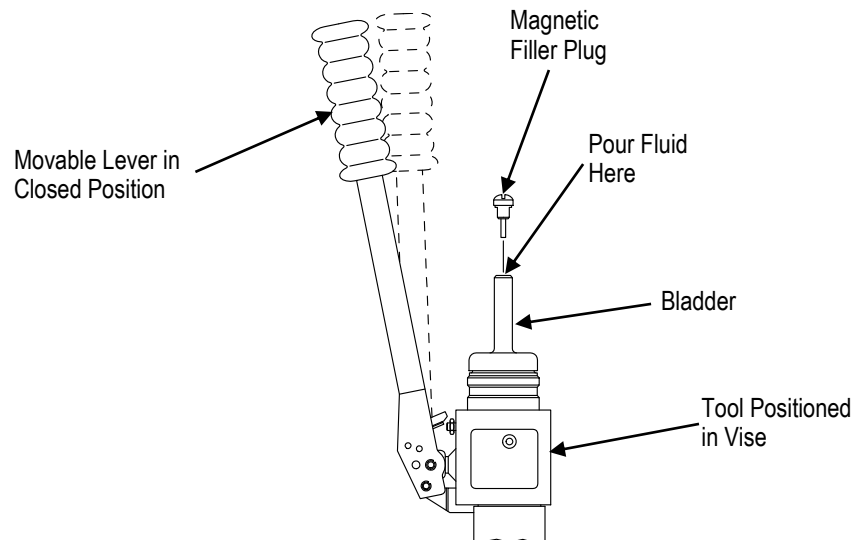

Figure 2

3. Turn the movable lever, and allow the lever to close until it stops. **DO NOT** depress the plunger when closing the lever.



NOTE

Keep lever in *CLOSED* position for remaining steps in this procedure.

4. Loosen the setscrew in cap of the stationary (reservoir) lever (see Figure 1).
5. With a view from the lever grip end, turn the lever **COUNTERCLOCKWISE** and remove the entire reservoir lever to expose the bladder.
6. Remove the magnetic filler plug.
 - ◆ If the bladder is full, no further check is necessary and the tool can be re-assembled.
 - ◆ If fluid level is low, proceed to the next step.
7. Fill the bladder with fluid.



NOTE

Use care to prevent air bubbles from forming while pouring the fluid.



NOTE

The recommended fluid is Dexron II; a transmission fluid available in automotive parts and department stores.

8. Refill the bladder to point of overflow, and replace the filler plug.
9. Re-assemble the stationary lever and tighten the cap setscrew.
The tool is now ready for use.

6. REPLACEMENT AND REPAIR

Customer-replaceable parts are listed in Figure 3. A complete inventory should be stocked and controlled to prevent lost time when replacement of parts is necessary. Parts other than those listed should be replaced by TE Connectivity to ensure quality and reliability. Order replacement parts through your TE representative, or call 1-800-526-5142, or send a facsimile of your purchase order to 717-986-7605, or write to:

CUSTOMER SERVICE (038-035)
 TE CONNECTIVITY CORPORATION
 PO BOX 3608
 HARRISBURG PA 17105-3608

For customer repair service, call 1-800-526-5136.

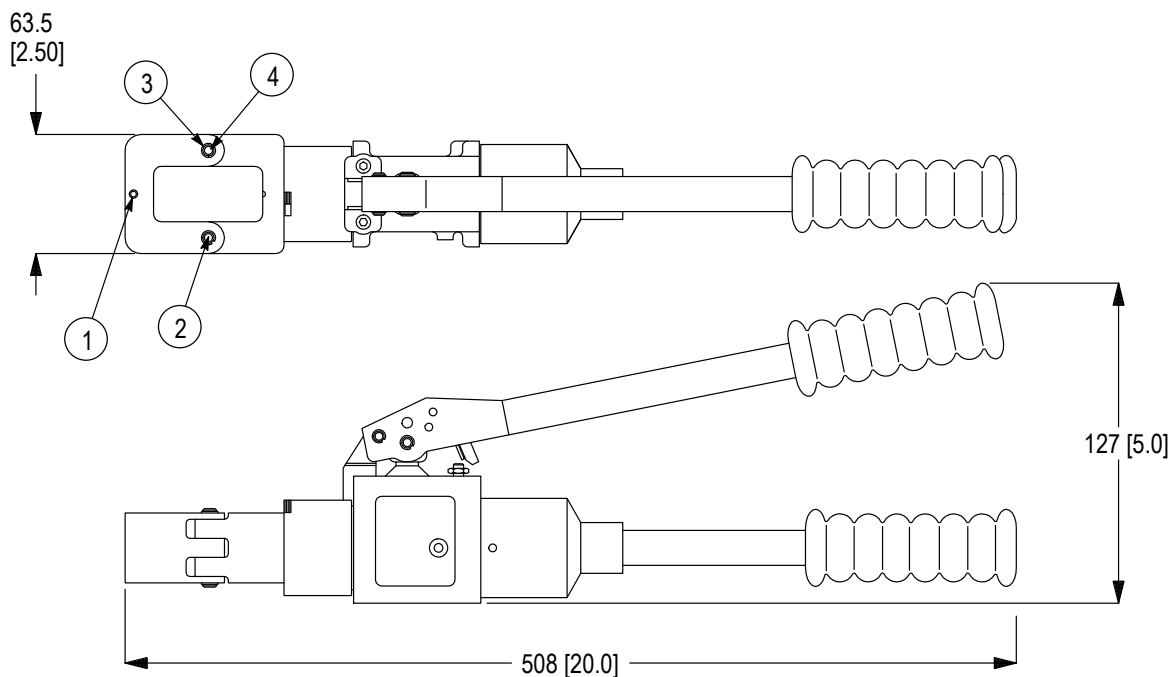

Weight: 3.6 kg [8 lbs]

REPLACEMENT PARTS			
ITEM	PART NUMBER	DESCRIPTION	QTY PER TOOL
1	4-21012-0	Setscrew	1
2	306209-1	Pin, Latch	1
3	21045-6	Ring, Retaining	2
4	301744	Pin, Retaining	1

Figure 3

7. REVISION SUMMARY

- ◆ Reformatted (including some paragraph numbering) and most current logo
- ◆ Added NOTE after paragraph 5.1.2.
- ◆ Added DANGER after paragraph 5.