

**PROPER USE GUIDELINES**

Cumulative Trauma Disorders can result from the prolonged use of manually powered hand tools. Hand tools are intended for occasional use and low volume applications. A wide selection of powered application equipment for extended-use, production operations is available.

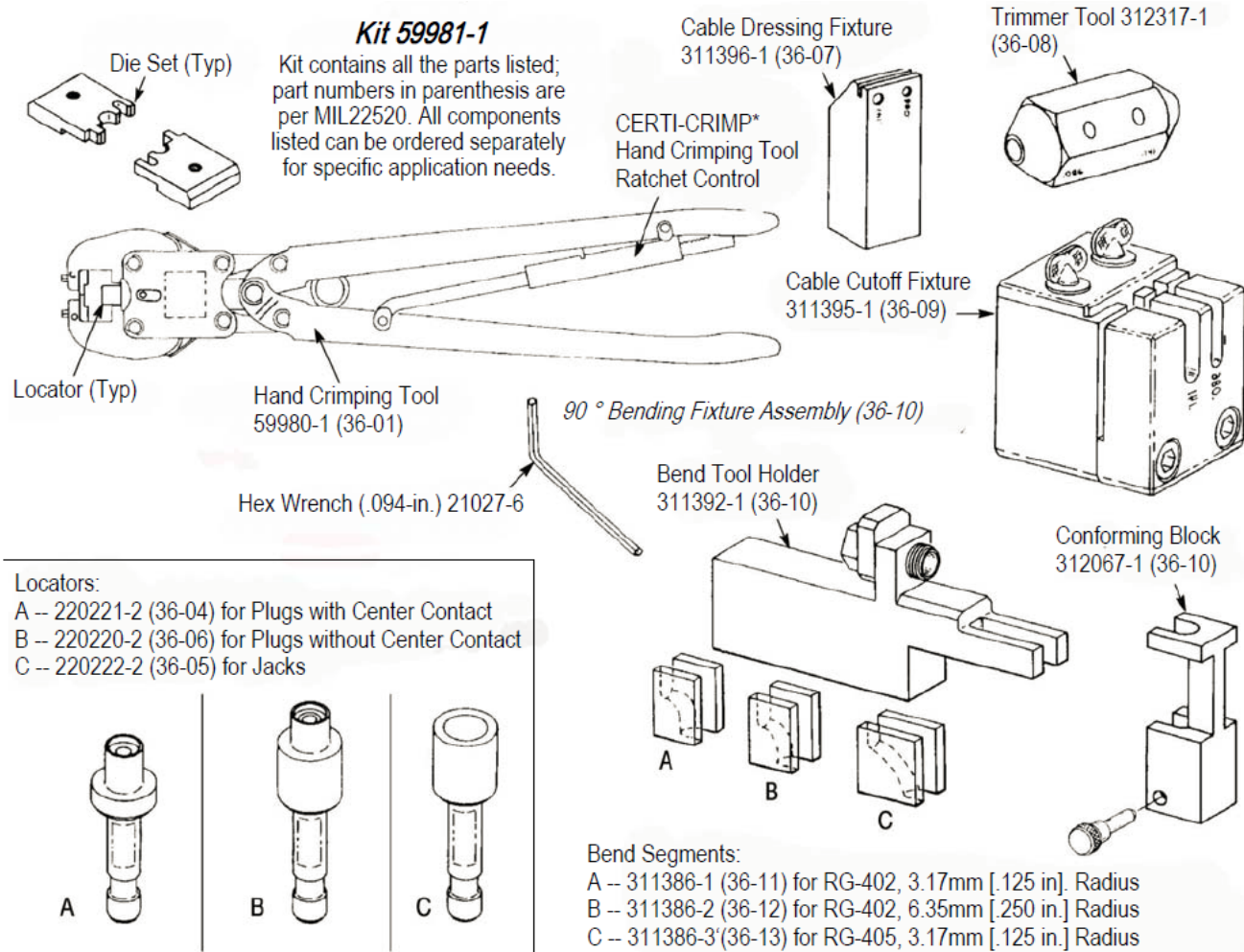

Figure 1

**1. INTRODUCTION**

Hand Crimping Tool and Cable Preparation Kit PN 59981-1 (shown in Figure 1) is used to prepare and terminate RG-402 (3.581mm [.141 in.] outside diameter) and RG-405 (2.184mm [.086 in.] outside diameter) semi-rigid coaxial cable onto SMA Series, N Series, and TNC Series connectors listed in Figure 2.

**i NOTE**  
 Read these instructions thoroughly before using the kit.

**i NOTE**  
 Dimensions in this instruction sheet are in metric units [with U.S. customary units in brackets]. Figures and illustrations are for identification only and are not drawn to scale.

Reasons for reissue of this instruction sheet are provided in Section 11, REVISION SUMMARY.

## 2. DESCRIPTION

The kit contains a hand crimping tool (with a CERTI-CRIMP hand crimping tool ratchet control), two interchangeable die sets (one for RG-402 cable and the other for RG-405 cable), and three locators for specific connector terminations (see Figure 1).



**NOTE**

The tool ratchet ensures full crimping of the connector. Once engaged, the ratchet will not release until the handles have been FULLY closed. Do NOT adjust the ratchet.

The kit also includes the following cable preparation tools: cable dressing fixture, trimmer tool, cable cutoff fixture, and a 90 degree bending fixture assembly.



**NOTE**

Special die sets and special locators are NOT supplied with Kit 59981-1. These items MUST be ordered separately. They include: (1) RG-402 cable, Die Set 312962-1 for plugs with retractable collars, and Locator 313585-1 for sealed plugs without center contacts; and (2) RG-405 cable, Die Set 313113-1, and Locator 220221-3 for short plugs, and Locator 312173-1 for right-angle plugs.

## 3. CABLE, CONNECTOR, AND LOCATOR SELECTION

Select the correct combination of cable, connector, hand tool locator, and die set from Figure 2.

CONNECTOR TYPE FOR RG-402 CABLE	Part Numbers <sup>1</sup>						
	TE	Category B		Category F		Hand Tool 59980-1	
		Military M39012/	TE	Military M39012/	TE	Die <sup>2</sup>	Locator <sup>2</sup>
Plug with Center Contact	---	79B3104	227743-1	79-3308	228634-1	312253-1	220221-2
Plug with Center Contact and Safety Wire Holes	228634-4	---	---	---	---	312253-1	220221-2
Sealed Plug with Center Contact	221328-1	---	---	---	---	312253-1	220221-2
Sealed Plug with Center Contact and Safety Wire Holes	221328-2	---	---	---	---	312253-1	220221-2
Plug without Center Contact	228635-2	92B3103	227531-1	92-3301	228635-1	312253-1	220220-2
Sealed Plug with Center Contact and Safety Wire Holes	221328-2	---	---	---	---	312253-1	220221-2
Plug without Center Contact	228635-2	92B3103	227531-1	92-3301	228635-1	312253-1	220220-2
Plug without Center Contact and with Safety Wire Holes	228635-4	---	---	---	---	312253-1	220220-2
Sealed Plug without Center Contact	221329-1	---	---	---	---	312253-1	313585-1‡
Plug with Retractable Collar	227531 227531-6	---	---	---	---	312962-1‡	220220-2
Sealed Plug with Retractable Collar	221329-3	---	---	---	---	312962-1‡	313585-1‡
Sealed Plug with Retractable Collar and Safety Wire Holes	221329-4	---	---	---	---	312962-1‡	313585-1‡
Right-Angle Plug	228626-2	---	---	80-3308	228626-1	312253-1	312173-1‡
Right-Angle Plug with Safety Wire Holes	228626-4	---	---	---	---	312253-1	312173-1‡
Sealed Right-Angle Plug with Safety Wire Holes	222066-2	---	---	---	---	312253-1	312173-1
Jack	228636-2	---	---	81-3208	228636-1	312253-1	220222-2
4-Hole Panel Jack	228637-2	---	---	---	---	312253-1	220222-2
Bulkhead Jack	228638-2	83B3004	227746-1	83-3208	228638-1	312253-1	220222-2
N Series Connectors: Front-Mounted Jack Rear-Mounted Jack Plug	228448-1 228658-1 228440-1	---	---	---	---	312253-1	220222-2
TNC Series Connectors: Rear-Mounted Jack Plug	228502-1 228179-2	---	---	---	---	312253-1	220222-2
Adapter Assemblies	228446-1 <sup>3</sup>	---	---	---	---	312253-1	220222-2

<sup>1</sup> Consult latest issue of MIL-C-39012 and QPL for current military dash numbers

<sup>2</sup> All items are included in Kit 59981-1, except those marked with ‡

<sup>3</sup> For both N Series and TNC Series

Figure 2 (cont'd)

CONNECTOR TYPE FOR RG-405 CABLE	Part Numbers <sup>1</sup>						
	TE	Category B		Category F		Hand Tool 59980-1	
		Military M39012/ TE	TE	Military M39012/ TE	TE	Die <sup>2</sup>	Locator <sup>2</sup>
Plug with Center Contact	---	79B3103	227868-1	79-3307	228639-1	312253-2	220221-2
Plug with Center Contact and Safety Wire Holes	228639-4	---	---	79-3207	228639-3	312253-2	220221-2
Short Plug with Center Contact	221447-1 221447-2	---	---	---	---	313113-1‡	220221-3‡
Short Plug with Center Contact and with Safety Wire Holes	221447-3 221447-4	---	---	---	---	313113-1‡	220221-3‡
Sealed Short Plug	221812-1	---	---	---	---	313113-1‡	220221-3‡
Sealed Short Plug with Safety Wire Holes	221812-2	---	---	---	---	313113-1‡	220221-3‡
Short Plug with Retractable Collar	221447-5	---	---	---	---	313113-1‡	220221-3‡
Right-Angle Plug	228583-2	---	---	80-3307	228583-1	312253-2	312173-1‡
Right-Angle Plug with Safety Wire Holes	228583-4	---	---	80-3207	228583-3	312253-2	312173-1‡
Sealed Right-Angle Plug	222264-1	---	---	---	---	312253-1	312173-1
Sealed Right-Angle Plug with Safety Wire Holes	222264-2	---	---	---	---	312253-1	312173-1
Jack	228640-2	---	---	81-3207	228640-1	312253-2	220222-2
4-Hole Panel Jack	---	82B3003	227870-1	83-3207	228641-1	312253-2	220222-2
Bulkhead Jack	227871-3 228642-2	83B3003	227871-1	83-3207	228642-1	312253-2	220222-2
TNC Series Connector Rear-Mounted Jack	228507-1	---	---	---	---	312253-2	220222-2
Adapter Assembly (For TNC Series Only)	228505-1 <sup>3</sup>	---	---	---	---	312253-2	220222-2

<sup>1</sup> Consult latest issue of MIL-C-39012 and QPL for current military dash numbers

<sup>2</sup> All items are included in Kit 59981-1, except those marked with ‡

<sup>3</sup> For both N Series and TNC Series

Figure 2 (end)

#### 4. CABLE PREPARATION

Semi-rigid cable must be properly prepared for termination. Correct use of cable preparation tools (cutoff fixture, dressing fixture, and trimming tool) will give the strip length and recommended pointing as shown in Figure 3, Detail A.

If TE Connectivity tools are not used for cable preparation, strip the cable to the dimension shown, and deburr (point) the center conductor as shown in Figure 3, Detail B, then proceed directly to Section 5, TOOL SETUP.

To prepare the cable:

1. Strip the outer cable jacket to the dimension provided in Figure 3. Make sure the cut is at a 90 degree angle to the cable length.
2. Point the center conductor.



**NOTE**

All cable terminated with connectors without center contacts must be pointed to ensure a sound connection.

3. Trim the cable dielectric to the strip length dimension shown in Figure 3. Be careful to avoid nicking the center conductor.
4. Brush the prepared cable end to remove any metallic debris that might be present.



**NOTE**

The cable can also be prepared by using Semi-Rigid Cable Stripping Machine 220211-2 with Stripping Kit 813599-[]]. Refer to Customer Manual 409-2909 for detailed operating procedures.

**Cable Preparation-Strip Length and Pointing**

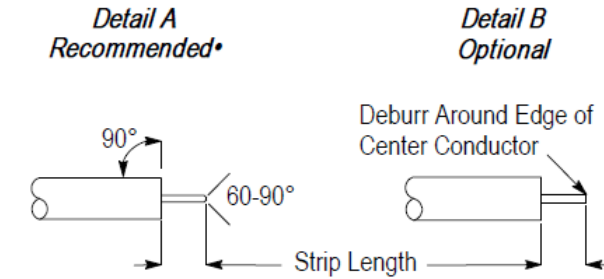

**Note:** Not to Scale

•Required on cables terminated to connectors without center contacts

Cable	Strip Length Dimension
RG-402, RG-405	2.16 ±0.13 [.085 ±.005]

Figure 3

**4.1. Cable Cutoff Fixture (FIGURE 4)**

Clamp the cable to the fixture, with the cable in the proper groove, and cut the cable end squarely with a Jeweler's saw with a 0.28 to 0.33 mm [.011 to .013 in.] blade thickness.



**NOTE**

On preformed cables with 90 or 180 degree bends, a minimum straight cable length of 12.70 mm [.500 in.] is required to clear the tool head during crimping.

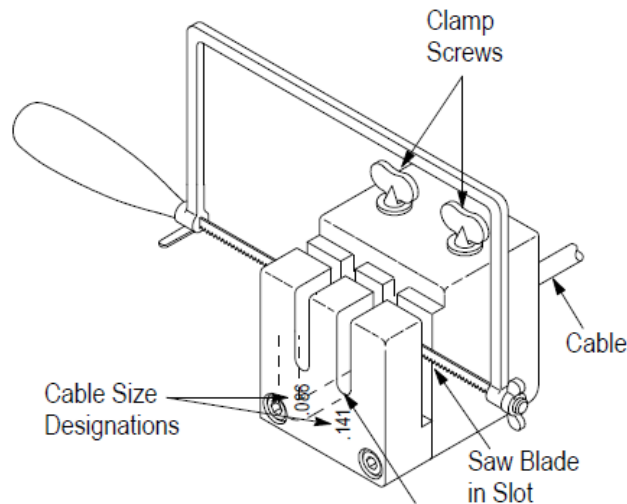

**NOTE:** Enter preformed cable from this end of fixture if cut end is desired up to 12.70 mm [.500 in.] of cable bend radius. Minimum straight cable length of 12.70 mm [.50 in.] is required for cable bend to clear tool head during crimping.

Figure 4

## 4.2. Cable Dressing Fixture and Trimmer Tool

### A. Cable Dressing Fixture

1. Place the cable dressing fixture in a vise.
2. Insert the cable into the hole corresponding to the cable size as shown in Figure 5, Detail A.

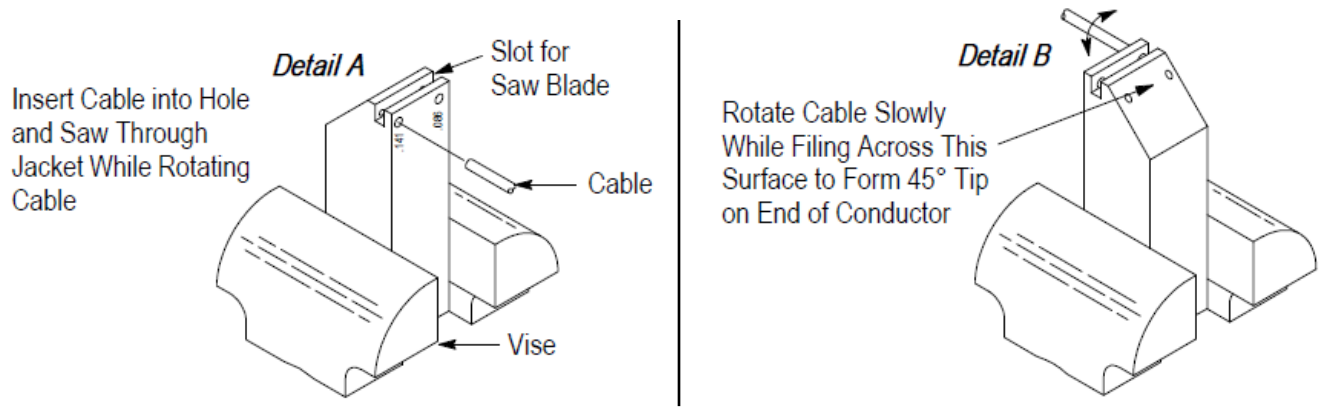

Figure 5

3. Using the Jeweler's saw, carefully cut through the cable shield while rotating the cable; maintaining pressure against the fixture.
4. Remove the cable from the fixture. Using a razor blade, carefully cut and remove the dielectric to expose the center conductor.



**CAUTION**  
DO NOT nick or score the center conductor.

### B. Trimmer Tool

To smooth the copper shield and dielectric, proceed as follows:

1. Slip the correct end of the trimmer tool over the exposed cable end (see Figure 6).

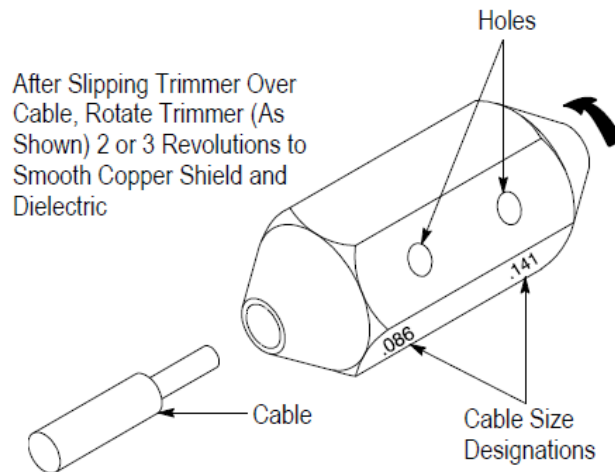

Figure 6

2. Push lightly against the cable while slowly rotating the trimmer tool clockwise several times.
3. Remove the trimmer tool and clean any chips from the cable end.
4. Re-insert the cable into the cable dressing fixture for pointing (refer to Figure 5, Detail B). Keep pressure against the fixture and rotate the cable slowly while filing on the 45 degree surface with a small pillar or mill file. Continue filing until the conductor offers no resistance to the file.
5. Remove the cable and brush off any chips.



**NOTE**

*A final inspection must be performed to ensure that no metal chips or burrs are present on the cable dielectric surface or on the cable shield inner or outer surfaces.*

**5. TOOL SETUP**

Before prepared cable can be crimped to a connector, the hand crimping tool must be set up with the appropriate locator and die set. Proceed as follows:

1. Select the proper hand tool locator from Figure 2.
2. Loosen the locator locking screw, insert the locator into the tool head cavity; making sure the locator is bottomed in the cavity, then re-tighten the locking screw (refer to Figure 7, Detail A).

*Detail A*

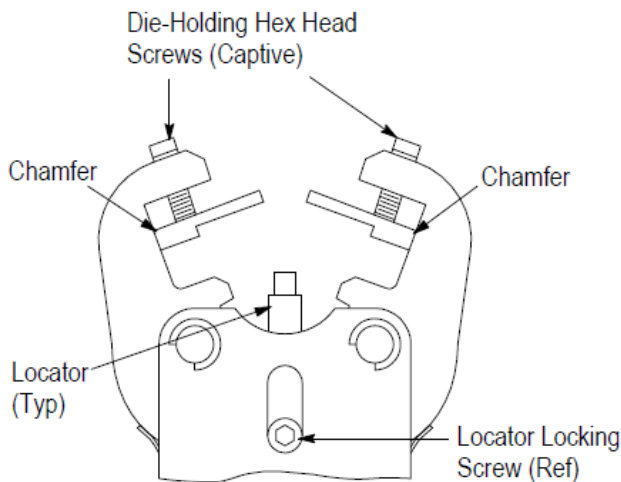

*Detail B*

Slip Cable in Locator Between Dies. Tighten Screws While Cable Holds Dies in Proper Alignment

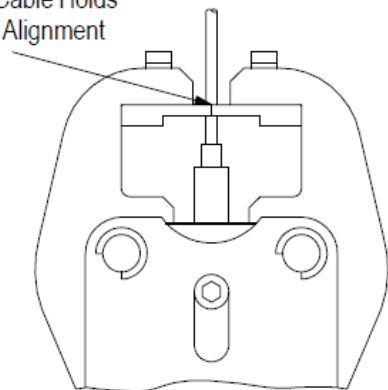

Figure 7

3. Select the proper die set for either RG-402 or RG-405 cable. Position each die on the respective tool jaw and make sure the chamfer is oriented as shown in Figure 7, Detail A.



**CAUTION**

*An unacceptable crimp will result if the die chamfers are not positioned as shown.*

4. Fasten the dies to the jaws with the screws, but do not tighten until the dies are aligned.  
To align the dies, place the cable inside the locator and squeeze the tool handles to close the tool. Check for even alignment of the dies, as shown in Figure 7, Detail B, then tighten the screws to secure the dies.



## 6. CRIMPING PROCEDURE



**NOTE**

Before crimping, insert the prepared cable into the **BACK** of the connector assembly until the cable bottoms on the shoulder of the connector assembly.

### 6.1. For Connectors with Fixed Collars (Except Right Angle Connectors)



**NOTE**

Figures 8 and 9 show typical plug and panel jack connectors with fixed collars.

Proceed as follows:

1. Carefully insert the cable into the connector until the cable bottoms on the shoulder of the connector.
2. Place the connector and cable inside the tool locator; making sure that:
  - the center conductor of center contact enters the locator hole, and
  - the connector is seated squarely on the locator.



**NOTE**

If crimping a panel jack to the cable, the sides of the panel jack should align with the tool jaws as shown in Figure 9.

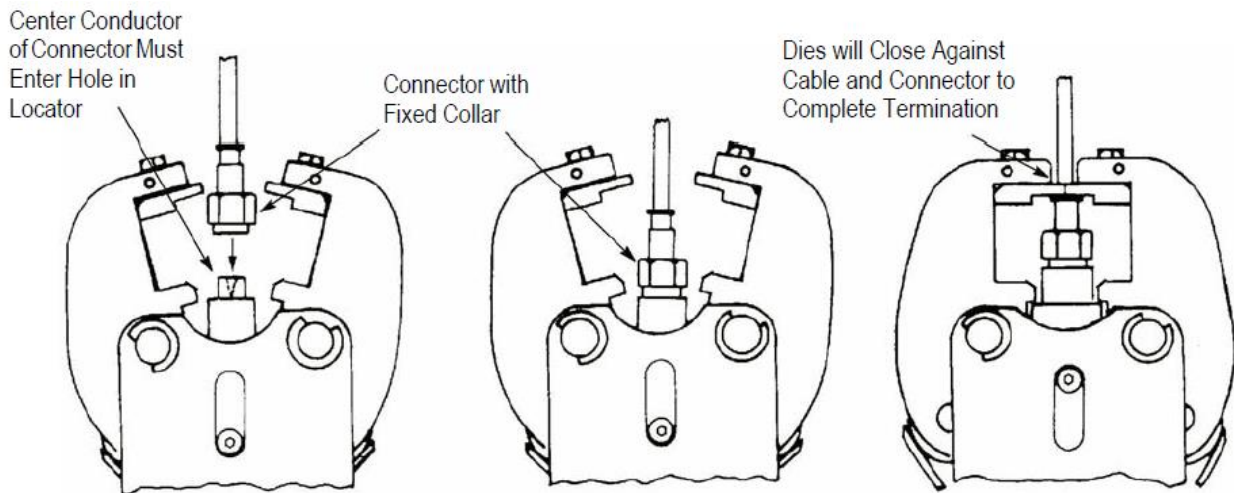

Figure 8

3. Support the cable-and-connector assembly, and squeeze the tool handles to complete the crimp as shown in Figure 9.

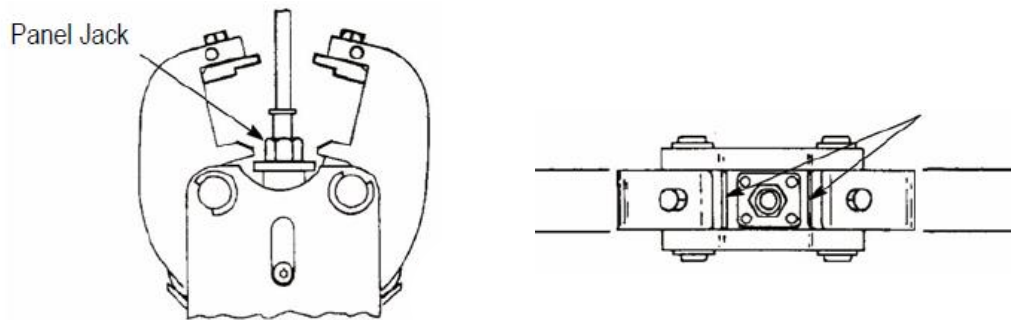

Figure 9

### 6.2. For Connectors with Retractable Collars

Connectors with sliding coupling nuts (shown in Figure 10) require Special Die Set 312962-1 which is not included in the kit and **MUST** be ordered separately.

Proceed as follows:

1. Slide the nut then the connector body (flange end first) onto the cable.
2. Place the connector body and cable inside the tool locator, making sure the center conductor enters the locator hole, and the coupling nut is positioned above the tool head.
3. Squeeze the tool handles to crimp the connector body to the cable.

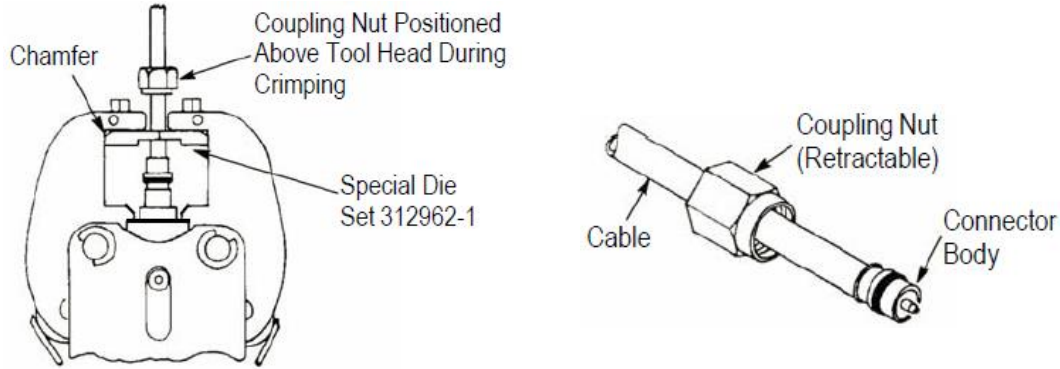

Figure 10

### 6.3. For Right-Angle Connectors

Right-angle connectors require Locator 312173-1 which is not included in the kit and **MUST** be ordered separately. Proceed as follows:

1. Slide the connector (flange end first) over the cable end as shown in Figure 11.
2. Place the connector and cable inside of the tool locator; making sure that:
  - the recessed area of the connector body sits squarely on the locator knob, and
  - the connector collar faces forward, as shown in Figure 11.
3. Support the cable and connector assembly, and squeeze the tool handles together to complete the crimp.

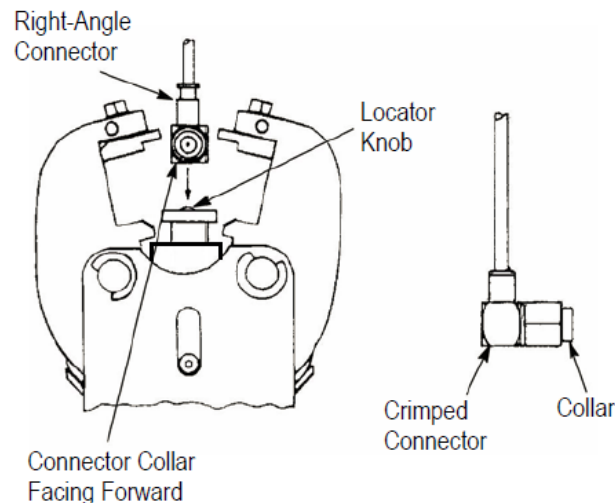

Figure 11



## 7. INTERNAL REFERENCE PLANES FOR CABLE

**NOTE**

The dimensions shown in Figure 12 are from the cable-bottoming surface or plane in the connector to the mating reference plane.

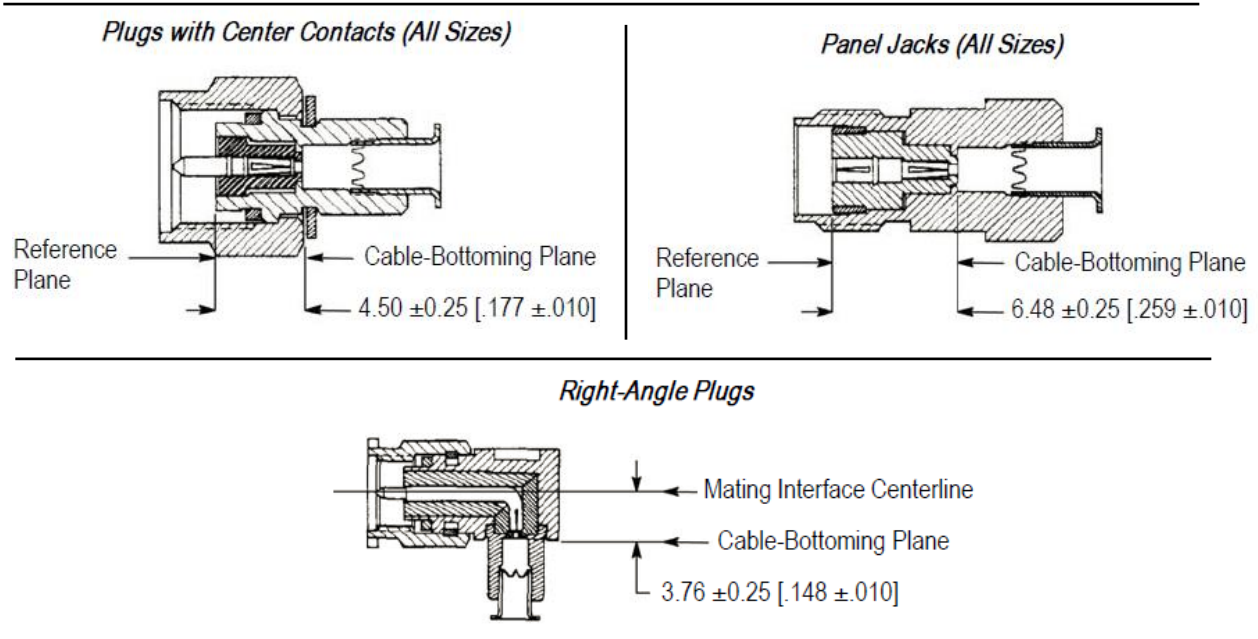
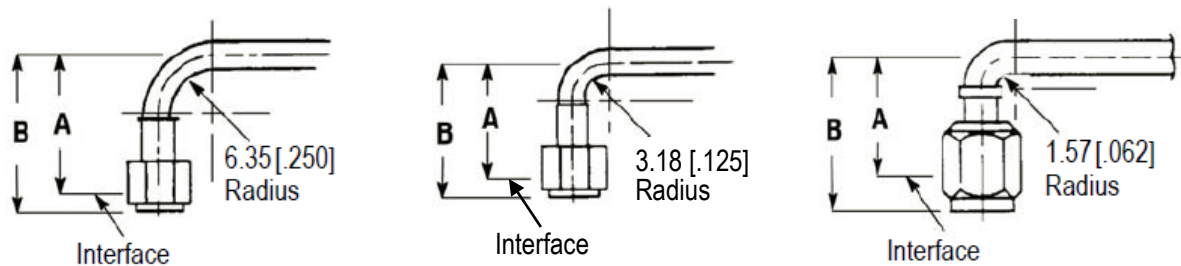

Figure 12

## 8. CABLE BENDING

The 90-degree bending fixture assembly is used to make precise right-angle bends on the cable near SMA plugs as shown in Figure 13. Bends can have a radius of 3.18mm [.125 in.] (on RG-402 or RG-405 cable), 6.35mm [.250 in.] (on RG-402 cable only), or 1.57mm [.062 in.] (on RG-405 cable only).



SMA Plug Type	Cable Size	Dimension					
		6.35 [.250] Radius		3.18 [.125] Radius		1.57 [.062] Radius	
		A	B	A	B	A	B
Plugs without Center Contact	RG-402	14.68 [.578]	18.11 [.713]	11.51 [.453]	14.94 [.588]	---	---
Plugs with Center Contact		19.18 [.755]	22.61 [.890]	16.00 [.632]	19.43 [.765]	---	---
Plugs with Center Contact	RG-405	---	---	15.34 [.604]	18.75 [.738]	13.72 [.540]	17.14 [.675]
Short Plugs		---	---	12.70 [.500]	15.88 [.625]	11.10 [.437]	14.27 [.562]

Figure 13

The spacer shown in Figure 14 must be positioned behind the dummy jack when bending:

- RG-402 cable to either 3.18mm [.125 in.] or 6.35mm [.250 in.] radii terminated onto plugs with center contacts, or
- RG-405 cable to 1.57mm [.062 in.] or 3.18mm [.125 in.] radii when terminated onto plugs with center contacts except Short Plugs 221447-[ ]. For short plugs, a special spacer is required and MUST be ordered separately from Special Kit 220224-2.

Loosen the dummy jack to insert the spacer, and retighten the jack before proceeding.

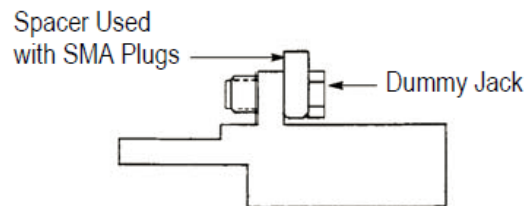

Figure 14

### 8.1. To Make 6.35 mm [.250 in.] Bends on RG-402 Cable or 3.18 mm [.125 in.] Bends on RG-405 Cable

1. Screw the terminated plug onto the dummy jack of the tool holder (see Figure 15).

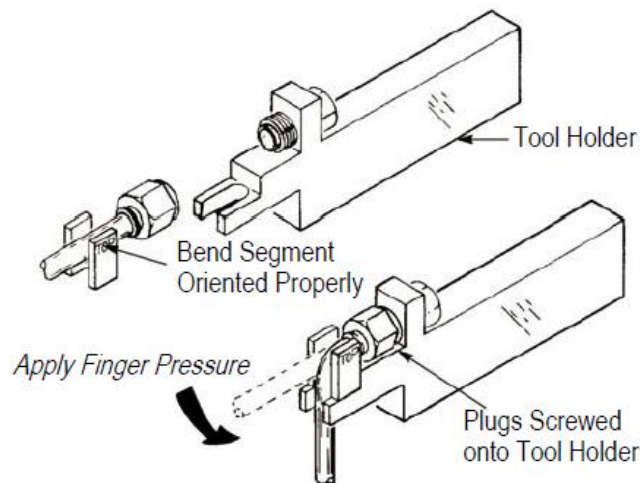

Figure 15

2. Slip the appropriate bend segment under the cable as shown.
3. Using finger pressure, bend the cable around the segment to the desired angle, to a 90 degree maximum.
4. Unscrew the plug from the tool holder.

### 8.2. To Make 3.18mm [.125 in.] Bends on RG-402 Cable

1. Make the 6.35mm [.250 in.] radial bend as described in Paragraph 8.1., and remove the plug from the tool holder.
2. Replace the 6.35mm [.250 in.] bend segment with the 3.18 mm [.125 in.] segment for RG-402 cable.
3. Re-attach the plug to the dummy jack of the tool holder.

- Place the conforming block over the cable with the tongue of the block in the slot of the tool holder, as shown in Figure 16.

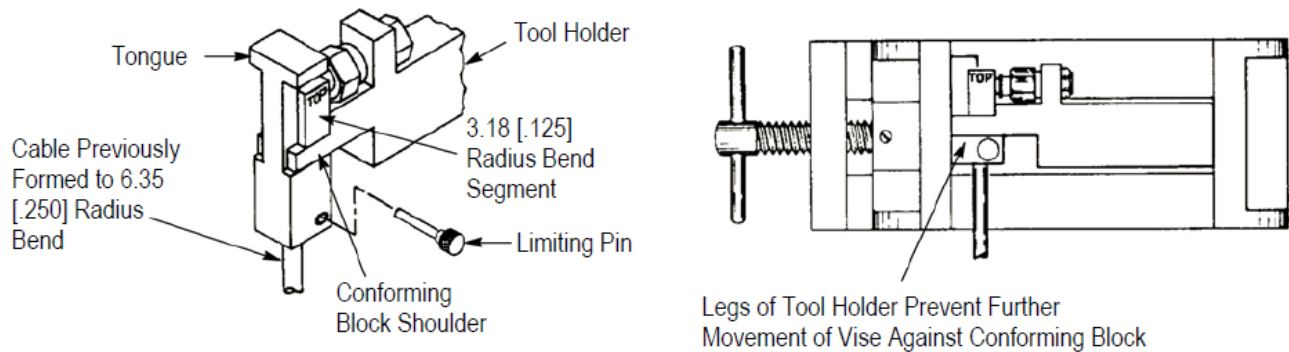

Figure 16

- Insert the limiting pin and slide the block against the opening.
- Place the assembly in a vise with a 69.85 mm [2.75 in.] opening.

**NOTE**

*Make sure the shoulders of the conforming block bear on the bottom surface of the tool holder BEFORE applying pressure in the vise.*

- Tighten the vise to force the conforming block into the slot.  
Continue to tighten until the legs of the tool holder prevent further movement of the vise jaws.
- Remove the assembly from the vise, and unscrew the plug from the fixture.
- Remove the conforming block and bend segment.

### 8.3. To Make 1.57 mm [.062 in.] Bends on RG-405 Cable

It is recommended that a special kit be used to make 1.57 mm [.062 in.] bends on RG-405 cable. Kit 220224-2 includes a limiting pin, a 90 degree bend tool body assembly, a 90 degree bend segment, and a conforming block. The figures referenced for the 6.35 mm [.250 in.] and 3.18 mm [.125 in.] bends will assist in making the 1.57 mm [.062 in.] bends. The following steps are recommended:

- Make the 3.18 mm [.125 in.] radial bend as described in Paragraph 8.1., and remove the plug from the tool holder.
- Replace the 3.18 mm [.125 in.] bend segment with the special 1.57 mm [.062 in.] bend segment, which is a part of Kit 220224-2.
- Re-attach the plug to the dummy jack of the tool holder.
- Place the special 1.57 mm [.062 in.] conforming block over the cable with the tongue of the block in the tool holder slot. The conforming block is part of Kit 220224-2.
- Insert the limiting pin and slide the block against the tool holder.
- Place the assembly in a vise with a 69.85 mm [2.75 in.] opening.
- Tighten the vise to force the conforming block into the slot.  
Continue to tighten until the legs of the tool holder prevent further movement of the vise jaws.
- Remove the assembly from the vise, and unscrew the plug from the fixture.
- Remove the special conforming block and special bend segment.

## 9. MAINTENANCE AND INSPECTION

Hand Crimping Tool and Cable Preparation Kit 59981-1 is inspected before shipment. The tool and kit should be inspected immediately upon arrival to ensure that they have not been damaged during shipment, and that they perform in accordance with the criteria described in this sheet. If the tool and kit are damaged upon arrival, retain the shipping container, file a claim with the carrier, and notify TE immediately.

### 9.1. Daily Maintenance

1. Remove dust, moisture, and other contaminants from the tool with a clean brush or a soft, lint-free cloth. DO NOT use objects that could damage the tool.
2. Make sure that the proper retaining pins are in place and are secured with the proper retaining rings.
3. Make certain that all pins, pivot points, and bearing surfaces are protected with a THIN coat of any good SAE 20 motor oil. DO NOT oil excessively.
4. When the tool is not in use, keep the handles closed to prevent objects from becoming lodged in the crimping chambers and store the tool in a clean, dry area.

### 9.2. Periodic Inspection

Regular inspections should be performed by quality control personnel. A record of scheduled inspections should remain with the tool and/or be supplied to supervisory personnel responsible for the tool. Though recommendations call for at least one inspection per month, the inspection frequency should be based on the amount of use, working conditions, operator training and skill, and established company standards. These inspections should be performed in the following sequence:

#### A. Visual Inspection

1. Remove all lubrication and accumulated film by immersing the tool (handles partially closed) in a suitable commercial degreaser that will not affect paint or plastic material.
2. Make certain all retaining pins are in place and are secured with retaining rings. If replacements are necessary, refer to Section 10, REPLACEMENT AND REPAIR.
3. Inspect crimping chambers for pitted or chipped surfaces.
4. Close the tool handles until the ratchet releases, then allow handles to open freely. If they do not open quickly and fully, the spring is defective and must be replaced. Refer to Section 10, REPLACEMENT AND REPAIR.

#### B. Gaging the Crimping Chamber

This inspection requires the use of a plug gage conforming to the dimensions listed in Figure 17a.

**i** **NOTE**  
TE does not manufacture or market these gages.

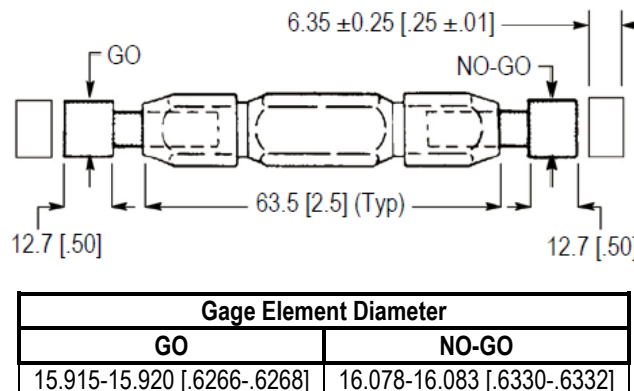

Figure 17a

To gage the crimping chambers, proceed as follows:

1. Insert Die Set 312253-1 as described in Section 5, TOOL SETUP. DO NOT insert the locator.
2. Close the tool handles until the ram touches the stop surfaces (refer to Figure 17b).

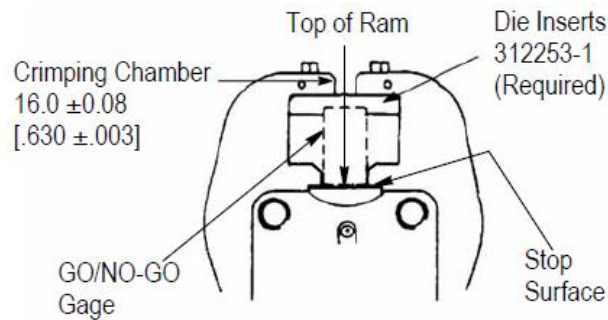

Figure 17b

3. Align the GO element of the gage with the crimping chamber so the top and bottom of the gage align with the surfaces of the die inserts and ram.

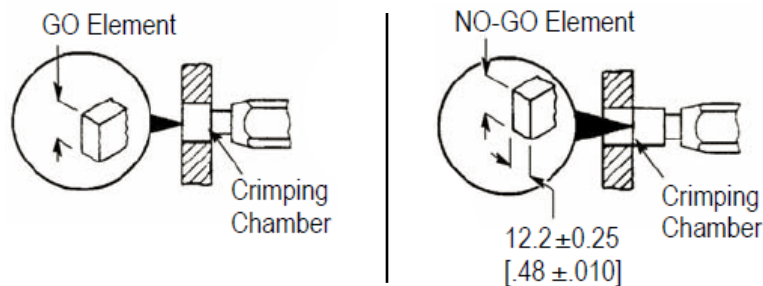

Figure 17c

4. Push the element straight into the crimping chamber without using force. The GO element must pass completely through the crimping chamber as shown in Figure 17c.
5. Align the NO-GO element and try to insert it straight into the crimping chamber. The NO-GO element may start entry, but must not pass completely through the crimping chamber, as shown in Figure 17c.

If the crimping chamber conforms to the gage inspection, the tool is considered dimensionally correct. If the crimping chamber does not conform to the inspection, the tool must be repaired before returning it to service. Refer to Section 10, REPLACEMENT AND REPAIR.

For additional information concerning the use of the plug gage, refer to Instruction Sheet [408-7424](#).

### C. CERTI-CRIMP Hand Crimping Tool Ratchet Control Inspection

Obtain a .0254 mm [.001 in.] shim that is suitable for checking the clearance between the ram and stop surfaces. To inspect the ratchet:

1. Squeeze the tool handles together until the ratchet releases. Allow the handles to open FULLY.
2. Place the shim between the top of the ram and the stop surfaces.
3. Support the shim and squeeze the tool handles together until the ratchet releases, then HOLD the tool handles in this position.
4. Check the clearance between the ram and the stop by trying to remove the shim. If shim cannot be removed, lubricate it with a THIN coat of any good SAE 20 motor oil and return it to service. If the shim can be removed, the ratchet is out of adjustment and must be repaired. Refer to Section 10, REPLACEMENT AND REPAIR.

### 10. REPLACEMENT AND REPAIR

Customer-replaceable parts for the cable preparation kit are listed in Figure 18, and customer-replaceable parts for the hand crimping tool are listed in Figure 19.

A complete inventory should be stocked and controlled to prevent lost time when replacement of parts is necessary. Replacement parts can be ordered from:

CUSTOMER SERVICE (038-035)  
 TE CONNECTIVITY CORPORATION  
 PO BOX 3608  
 HARRISBURG PA 17105-3608

Parts other than those specified in Figures 18 and 19 must be replaced to ensure correct operation of the tool. For customer repair service, please contact a TE representative at 1-800-526-5136.

### 11. REVISION SUMMARY

- Added interface callout and revised radius dimension to middle object of Figure 13.
- Divided original Figure 17 into 3 parts; 17a, 17b, and 17c.
- Hyperlinked Instruction Sheet 408-7424
- Put TE Part Numbers in numerical order (Figure 18)
- Added Line 7 to paragraph 8.3.

Cable Preparation Replacement Parts		
TE Part Number	Military Part Number 22520/	Description
13126-1	---	Carrying Case
13127-1	---	Case Insert
21027-6	---	Hex Wrench, .0938-in.
59980-1	36-01	Hand Tool (Locator and Dies Not Included with Tool)
220220-2	36-06	Plug Locator without Center Contact
220221-2	36-04	Plug Locator with Center Contact
220222-2	36-05	Jack Locator
220224-1	36-10	90 Degree Bending Fixture Assembly
307581-1	36-10	Limiting Pin
311386-1	36-11	Bend Segment, RG-402, 3.18 mm [.125 in.] Radius
311386-2	36-12	Bend Segment, RG-402, 6.35 mm [.250 in.] Radius
311386-3	36-13	Bend Segment, RG-405, 3.18 mm [.125 in.] Radius
311392-1	36-10	Bend Tool Holder
311395-1	36-09	Cutoff Fixture
311396-1	36-07	Cable Dressing Fixture
312067-1	36-10	Conforming Block
312253-1	36-03	Dies (2 for RG-402 Cable)
312253-2	36-02	Dies (2 for RG-405 Cable)
312317-1	36-08	Trimmer Tool

Figure 18



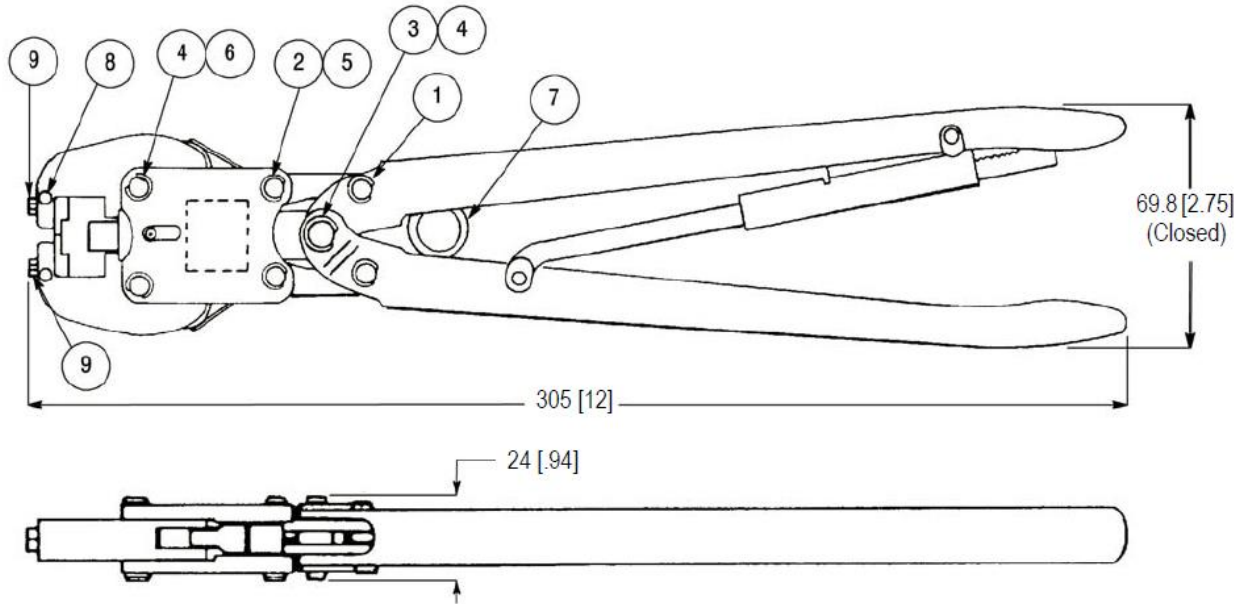

Weight: 0.9 kg [2 lb]

Hand Crimping Tool Replacement Parts			
Item	Part Number	Description	Qty Per Tool
1	300388	Pin, Retaining	2
2	21045-3	Ring, Retaining, External, Crescent	8
3	300389	Pin, Retaining	1
4	21045-6	Ring, Retaining, External, Crescent	6
5	305340	Pin-Retaining	2
6	305340	Pin-Retaining	2
7	2-304668-9	Spring	1
8	21028-5	Pin, Slotted Spring	2
9	312065-1	Screw, Special	2

Figure 19