

THIS DRAWING IS UNPUBLISHED. RELEASED FOR PUBLICATION
 © COPYRIGHT - By - ALL RIGHTS RESERVED.

LOC	DIST	REVISIONS					
AF	50	P	LTR	DESCRIPTION	DATE	DWN	APVD
			AE	REVISED PER ECR-12-013445	18OCT12	KH	PD

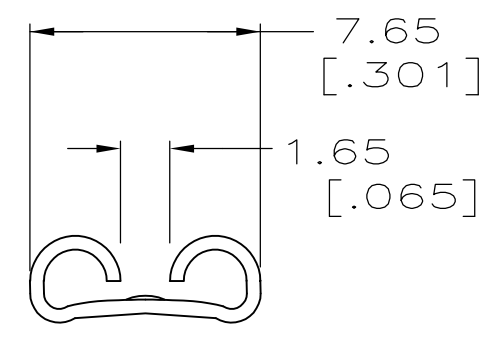
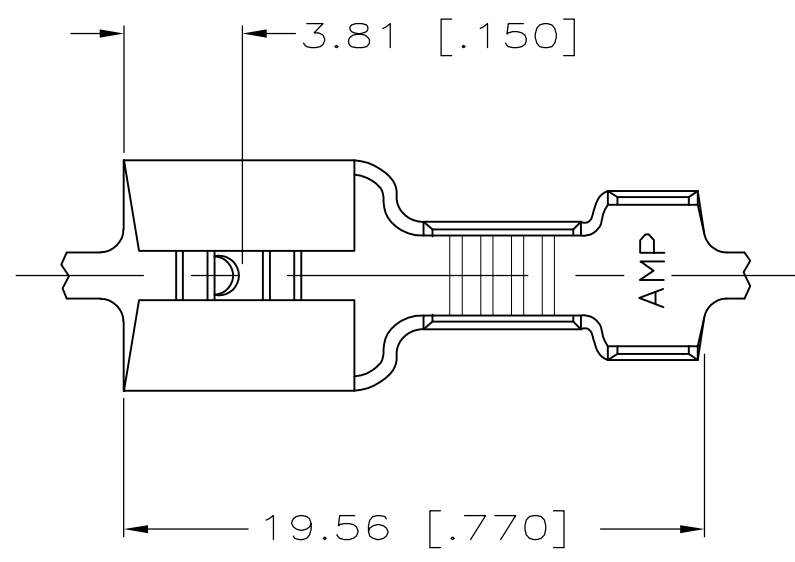

VIEW A-A

- 1 DIM'S IN BRACKETS ARE IN INCHES.
- 2 CONTINUOUS STRIP ON REELS.
- 3 FOREIGN PRODUCTION ONLY.
- 4 MATING TAB THK IS 0.81±0.025[.032±.001].
- 5 WIRE SIZE IS [#14-#10] AWG.
- 6 INSULATION DIA IS 3.81-5.08 [.150-.200].
- 7 REVERSE REELING W/ PAPER INTERLEAVING
- 8 PRELIMINARY - NOT FOR PRODUCTION
- 9 FOR AMP ITALY ONLY, NOT STRESS RELIEVED.

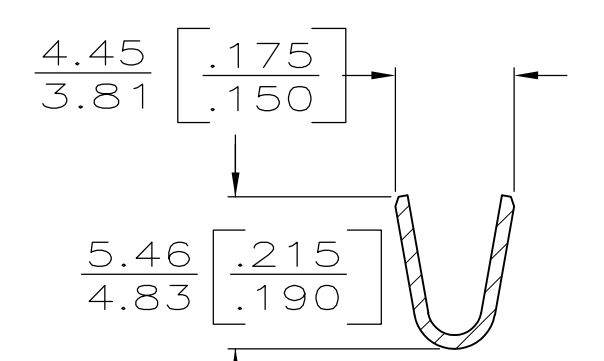
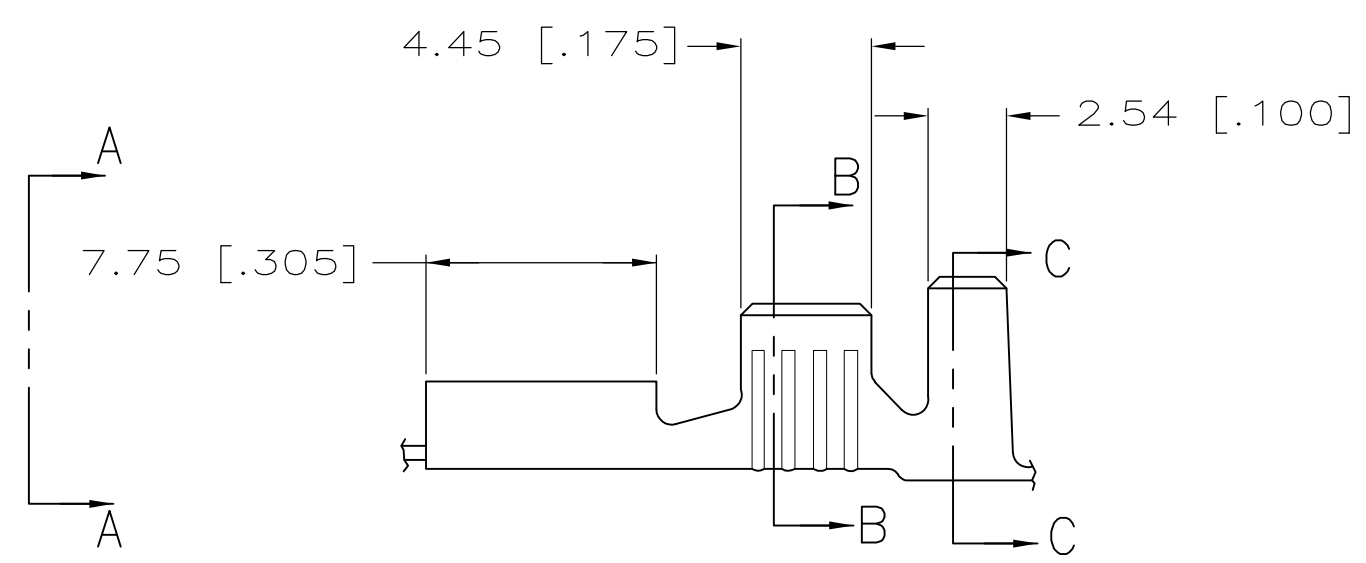

SECT B-B

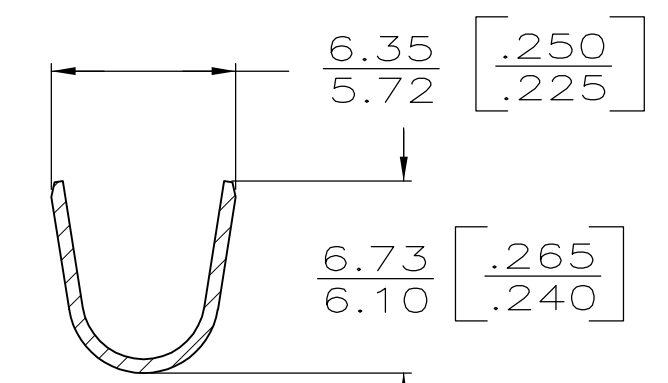

SECT C-C

0.46 [.018] BRASS	9	1-41450-1
0.46 [.018] BRASS	7/8	41450-3
BRASS	3	41450-2
0.46 [.018] BRASS	3	41450-1
BRASS		41450
MATERIAL		PART NO

0	5.33 [.210]	5.59 [.220]	F	3.30 [.130]	2.90 [.114]	5.0mm ² [10]
					2.39 [.094]	3.0mm ² [12]
					2.08 [.082]	2.0mm ² [14]
TYPE	WIDTH	STRIP LENGTH ±0.38 [±.015]	TYPE	WIDTH	±.051 [±.002] HEIGHT	WIRE
INSUL BARREL CRIMP			WIRE BARREL CRIMP			

THIS DRAWING IS A CONTROLLED DOCUMENT.

DIMENSIONS: mm [INCHES]

TOLERANCES UNLESS OTHERWISE SPECIFIED:

0 PLC	± -
1 PLC	± -
2 PLC	± 0.25 [.010]
3 PLC	± -
4 PLC	± -
ANGLES	± -
FINISH	TIN

MATERIAL: SEE TABLE

DWN: JR RUTH 2/7/86
 CHK: G YETTER 2/7/86
 APVD: R KUZO 2/7/86
 PRODUCT SPEC: —
 APPLICATION SPEC: —
 WEIGHT: —

STE TE Connectivity

RECEPTACLE, FASTON, .250 SERIES

SIZE	CAGE CODE	DRAWING NO	RESTRICTED TO
A3	00779	C-41450	—

CUSTOMER DRAWING SCALE: 4:1 SHEET: 1 OF 1 REV: AE