

NUMBER 41647

© 1971 BY AMP INCORPORATED. ALL RIGHTS RESERVED. AMP PRODUCTS COVERED BY PATENTS AND/OR PATENTS PENDING. APPROVED PER GOVT CONTRACT NO.

REVISIONS				
SYM	ZONE	DESCRIPTION	DATE	APPROVAL
L		REVISED & REDRAWN	7-781	
M		OBSOLETE 41833 & 41222	2102 DR	
N		OBSOLETE 41937	2934	
P		PRINTING MISTAKE LOC. WAS ABT	3347	
R		REACTIVATED 41222	ECN 49	
S		OBSOLETE 46033-1 & 42818-1	EA 1049	
T		REVISED PLATING	EA 1515	
U		BRIGHT TIN-LEAD WAS BRIGHT TIN	EA 1818	
V		UPDATED NAME	EA 2071	
W		REVISED GOLD PLATING	EA 2139	

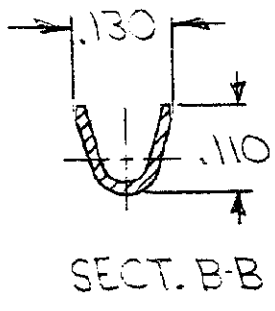
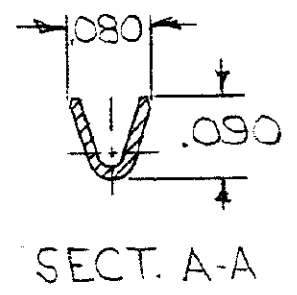
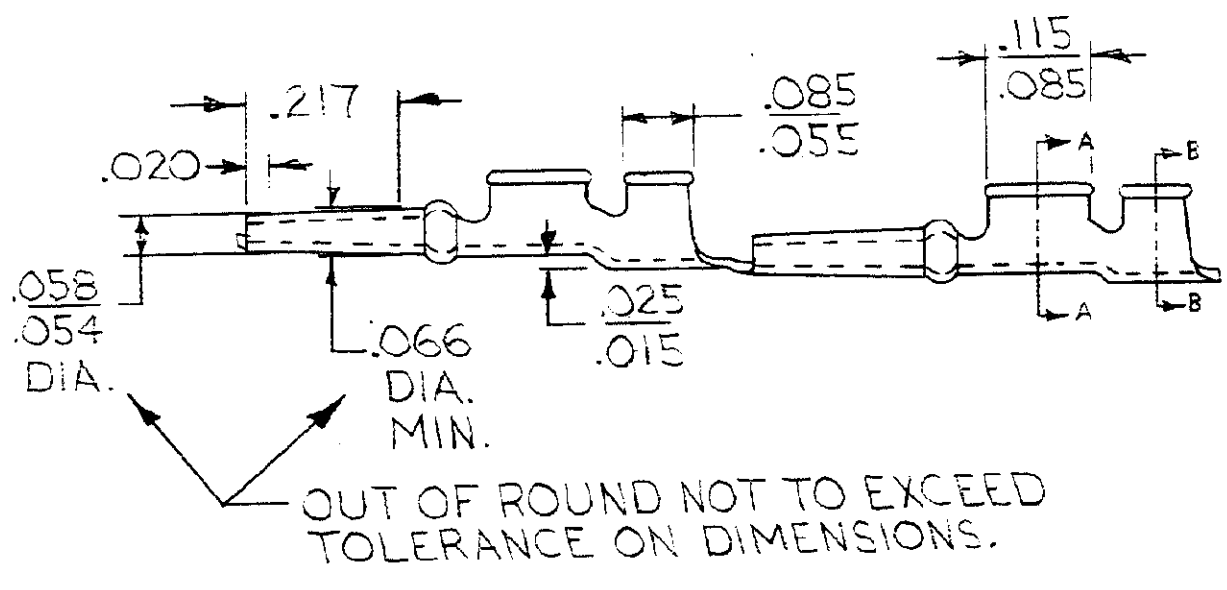
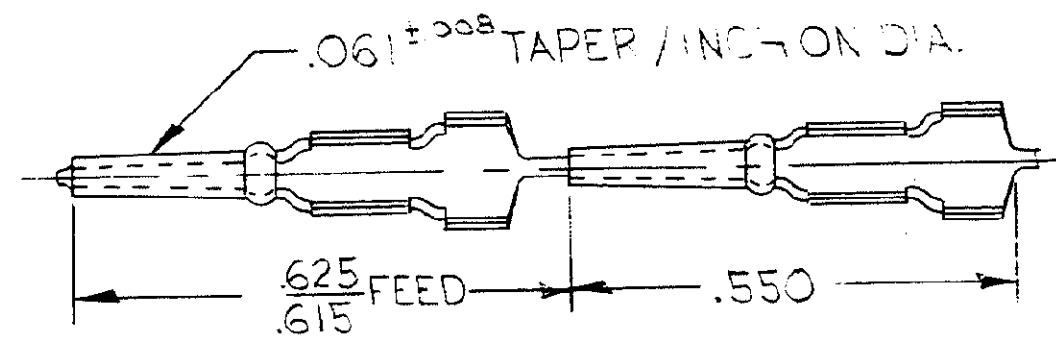

OUT OF ROUND NOT TO EXCEED TOLERANCE ON DIMENSIONS.

STRIP

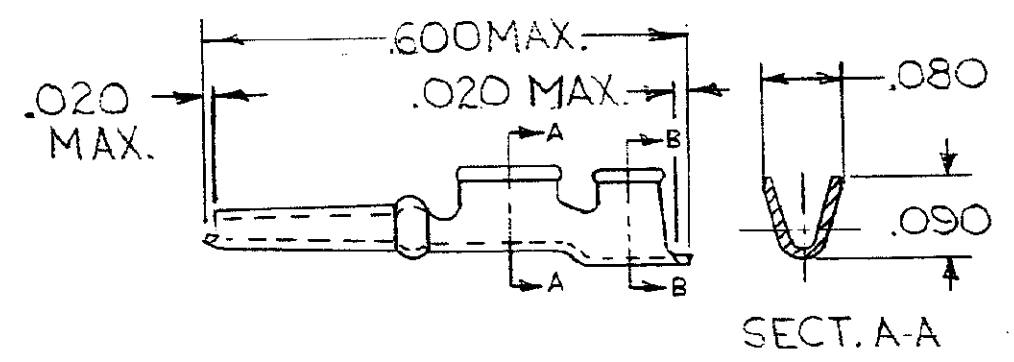

SECT. A-A  
LOOSE PIECE

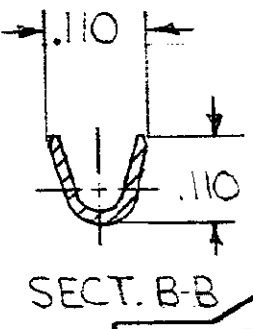

SECT. B-B

STRIP NO.	LOOSE PIECE NO.	WIRE SIZE	INSUL. SIZE	FINISH	INSERT. TOOL	HAND TOOL	C. H.
41222	~	#24-#22	.065-.080	PLAIN	380306-3	47042	.042
66033-1	42818-1			.0002 GOLD OVER .00005 NICKEL			
41863	41939			.0001 GOLD OVER .0001 SILVER			
41649	41666			.00003 GOLD OVER .00005 NICKEL			
41648	41665			.0002 SILVER			
41647	41664	#24-#22	.065-.080	.0001 BRIGHT TIN-LEAD	380306-3	47042	.042

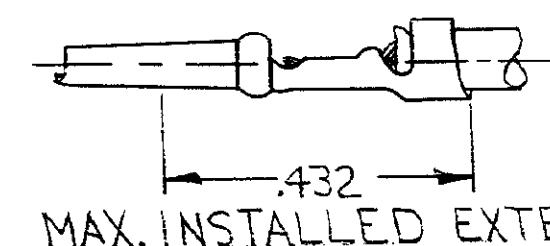
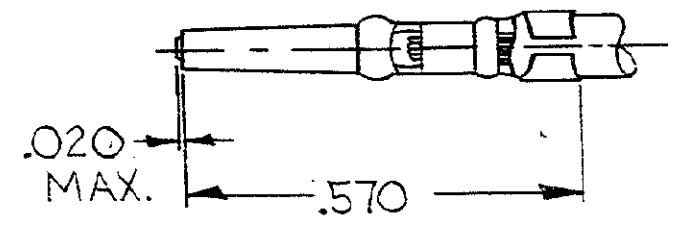

CRIMPED VERSION

AMP INFO LOC 12 W	QTY RECD	NOMENCLATURE OR DESCRIPTION	PART OR IDENTIFYING NO
LIST OF MATERIALS OR PARTS LIST			
OTHERWISE SPECIFIED DIMENSIONS ARE IN INCHES TOLERANCES ON		SIGNATURE	DATE
FRACTIONS = #/	DECIMALS = .010	DR. M.A. Malt	8/12/83
ANGLES = #		CHK. J. Kaufman	11/15/83
MATERIAL	HEAT TREAT	DSGN ENGR. K. Helms	8/16/83
0160 COML BRASS	—#—	APPD. J. Malt	11/16/83
FINISH	OTHER APPD.	AMP INCORPORATED HARRISBURG, PENNSYLVANIA	
SEE TABLE		PIN, TAPER, INSULATION SUPPORT, "53" SERIES	
		CODE IDENT NO	SIZE NUMBER
		00779 C	41647
		SCALE 4:1	