

THIS DRAWING IS UNPUBLISHED. RELEASED FOR PUBLICATION
 © COPYRIGHT BY TYCO ELECTRONICS CORPORATION. ALL RIGHTS RESERVED.

LOC	DIST	REVISIONS					
		P	LTR	DESCRIPTION	DATE	DWN	APVD
AF	50		B1	ECR-06-023927(REDRAWN IN AUTOCAD)	05JUL06	HMR	GP

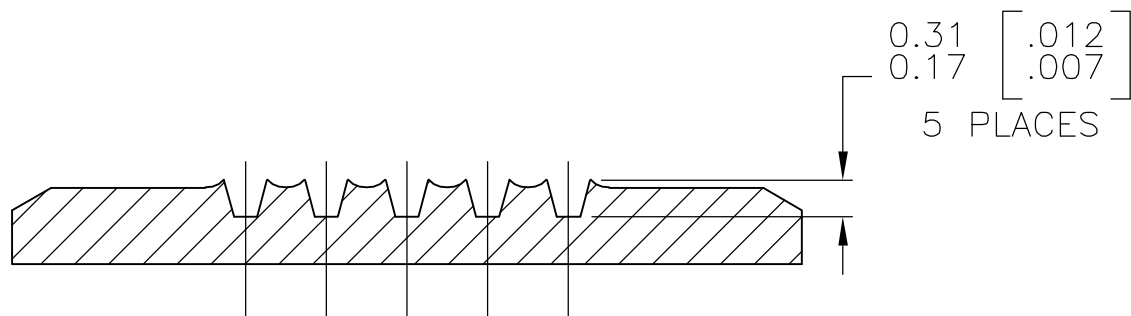
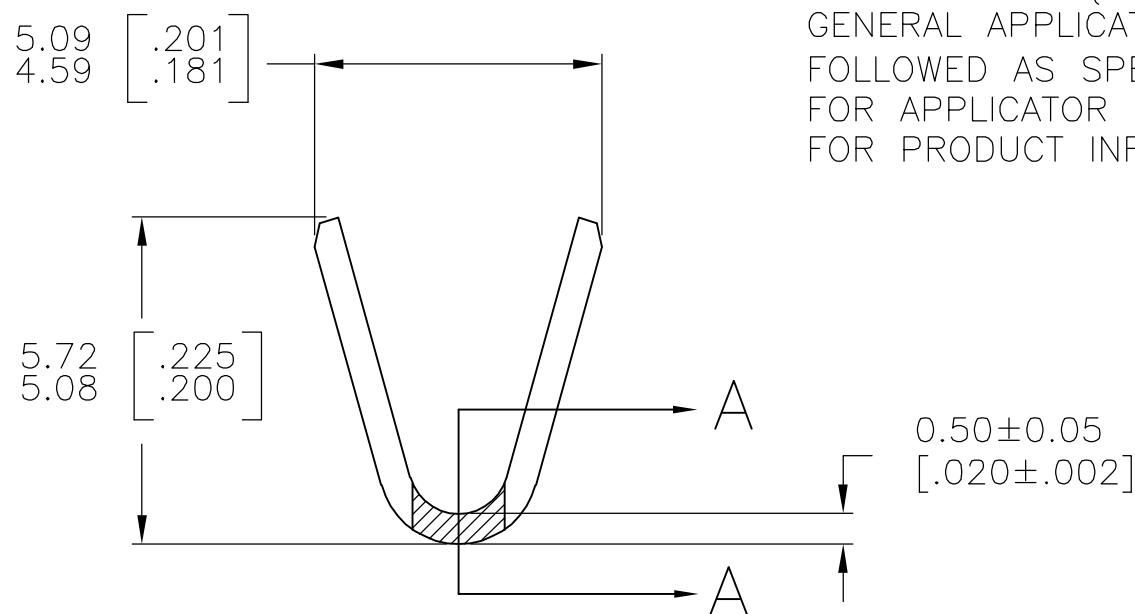
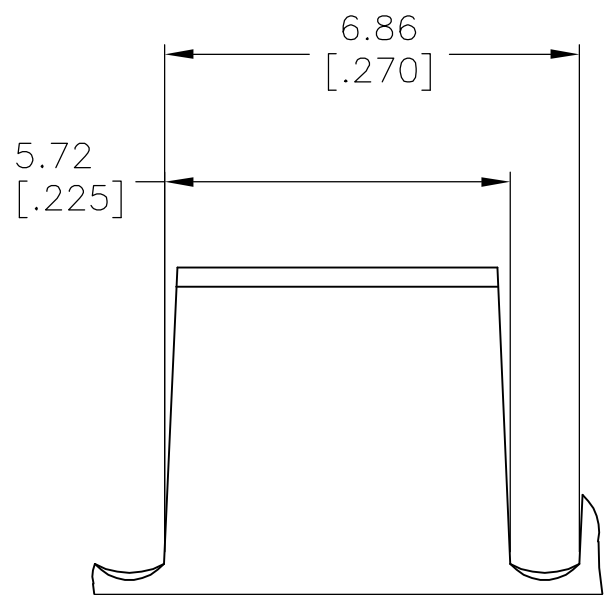
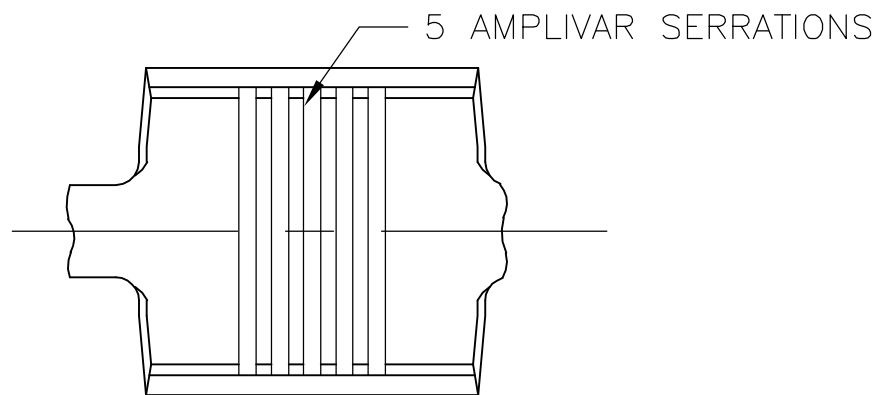

SECTION A-A
SCALE 20:1

- CONTINUOUS STRIP ON REELS.
- DIMENSIONS IN BRACKETS ARE IN INCHES.
- FOR ADDITIONAL INFORMATION, SEE APPLICATION SPEC. 114-2009.
- WIRE RANGE: 3000-7000 CMA.
- CRIMP WIDTH: .140 F TYPE (AMPLIVAR THRU)
 CRIMP HEIGHT (±.002)=(TOTAL CMA+14,600)/243,900
 GENERAL APPLICATION GUIDELINES MUST BE FOLLOWED AS SPECIFIED IN CATALOG #82221
 FOR APPLICATOR INFORMATION CALL:1-800-722-1111
 FOR PRODUCT INFORMATION CALL:1-800-522-6752

41900
PART NO

THIS DRAWING IS A CONTROLLED DOCUMENT.		DWN RAGHAVENDRA 05JUL06	tyco Tyco Electronics Corporation Harrisburg, PA 17105-3608	
DIMENSIONS: mm [INCHES]		CHK G.D.PORTA	APVD G.D.PORTA	
TOLERANCES UNLESS OTHERWISE SPECIFIED:		NAME		
0 PLC ± -		PRODUCT SPEC		
1 PLC ± -		APPLICATION SPEC		
2 PLC ± -		SIZE CAGE CODE DRAWING NO RESTRICTED TO		
3 PLC ± 0.38 [.015]		A3 00779 C-41900		
4 PLC ± -		SCALE 8:1 SHEET 1 OF 1 REV B1		
ANGLES ± 1' 0"		CUSTOMER DRAWING		
MATERIAL BRASS	FINISH TIN PLATE	WEIGHT -		