

THIS DRAWING IS UNPUBLISHED. RELEASED FOR PUBLICATION
 © COPYRIGHT BY TYCO ELECTRONICS CORPORATION. ALL INTERNATIONAL RIGHTS RESERVED.

LOC	DIST	REVISIONS					
AF	50	P	LTR	DESCRIPTION	DATE	DWN	APVD
			C2	REVISED PER ECR-08-008189	24NOV08	HMR	DD

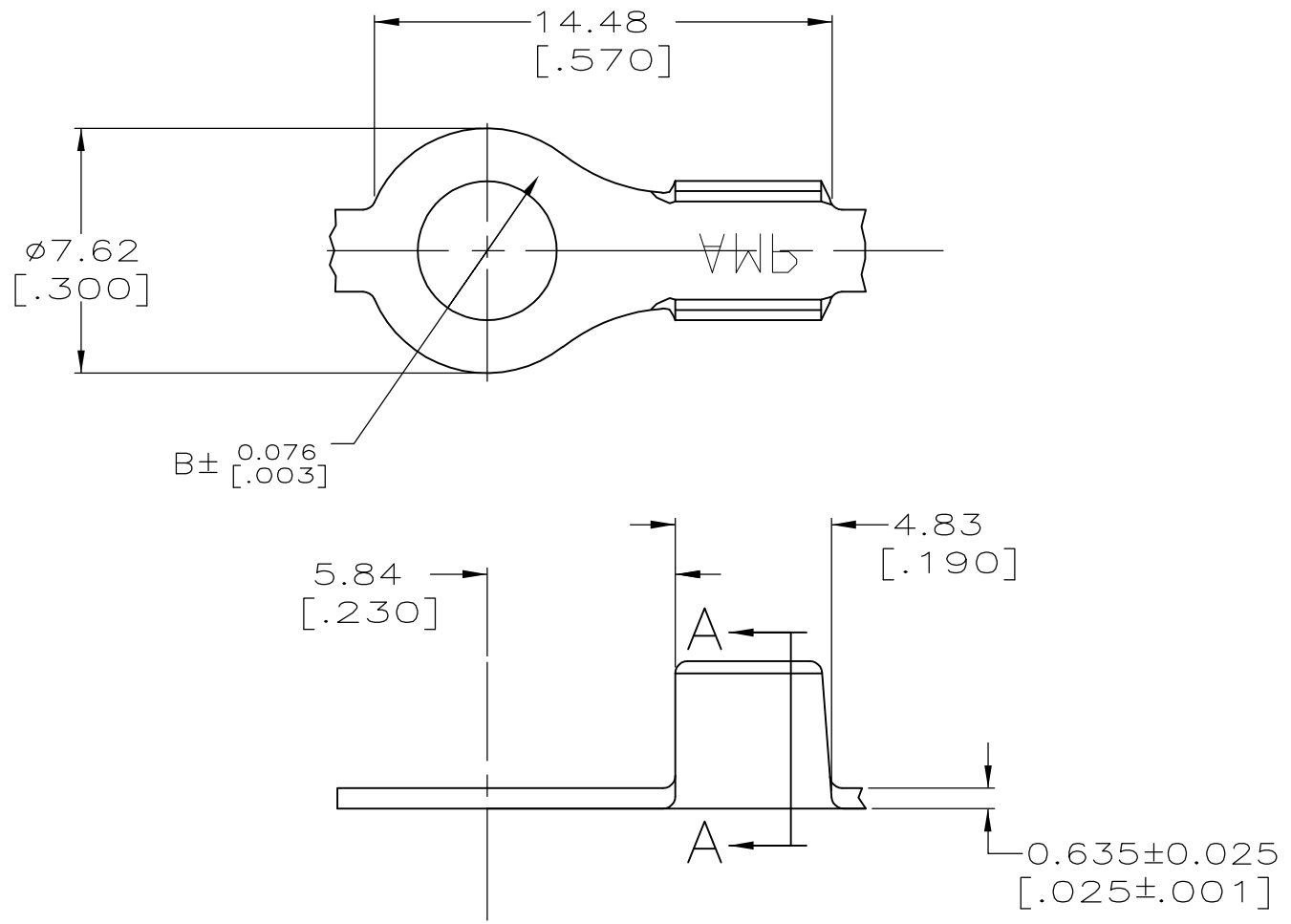

- 1 CONTINUOUS STRIP ON REELS.
- △ 2 TIN PLATING.
- 3 WIRE RANGE: 0.8–2.0mm² [18–14] AWG.
- △ 4 PACKAGED WITH INTERLEAVING PAPER.
- △ 5 PRELIMINARY – NOT FOR PRODUCTION.

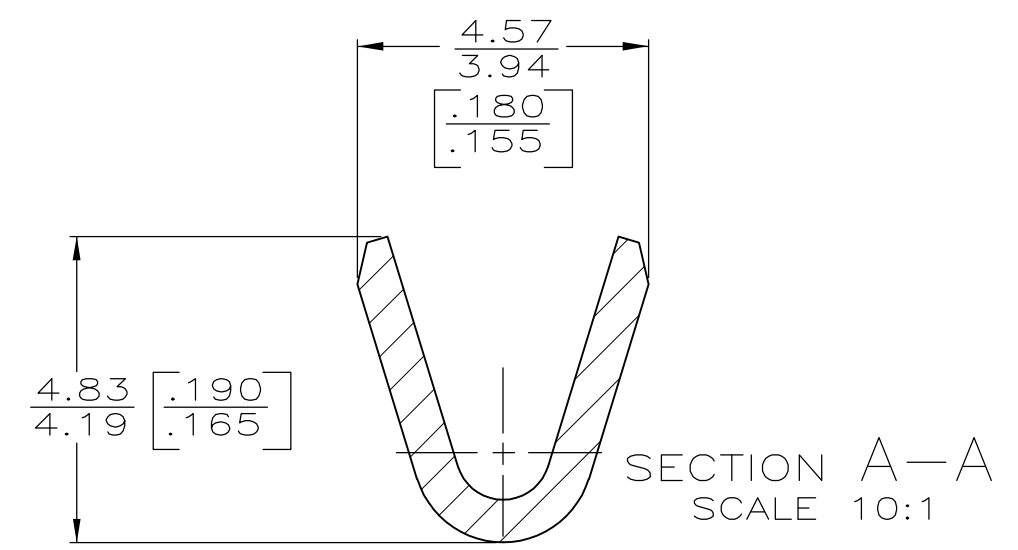

△ 4	.171	△ 5	42111-4
	.197		42111-3
	.171		42111-2
	.145		42111-1
	B DIMENSION		PART NUMBER

F	3.56 [0.140]	2.21 [0.087]	2.0mm ² [14]
		2.03 [0.080]	1.3mm ² [16]
		1.93 [0.076]	0.8mm ² [18]
TYPE	WIDTH	±0.051 [±0.002] HEIGHT	WIRE
WIRE BARREL CRIMP			

THIS DRAWING IS A CONTROLLED DOCUMENT.

DIMENSIONS: mm [INCHES]	TOLERANCES UNLESS OTHERWISE SPECIFIED:	DWN 9AUG2006 MICHAEL S. FEHER	Tyco Electronics Corporation Harrisburg, PA 17105-3608
	0 PLC ± - 1 PLC ± - 2 PLC ± - 3 PLC ± 0.38 [015] 4 PLC ± - ANGLES ± -	CHK 09AUG2006 DONALD F. DECKER APVD 09AUG2006 DONALD F. DECKER	
MATERIAL	FINISH	PRODUCT SPEC	NAME
#1 HARD BRASS	△ 2	APPLICATION SPEC	RING
		WEIGHT	SIZE CAGE CODE DRAWING NO RESTRICTED TO
		CUSTOMER DRAWING	A3 00779 C-42111
		SCALE 5:1	SHEET 1 OF 1 REV C2