

LOC AP DIST -

REVISIONS

P	LTR	DESCRIPTION	DATE	DWN	APVD
D1		REDRAW BY CAD ECO-12-014149	23AUG2012	NCL	DAO
D2		REV. BY ECO-13-014548	13SEP2013	HC	WLS
D3		REVISED BY ECO 16-003725	23JUN2016	HC	WLS
D4		REV. BY ECO 17-010545	18JUL2017	HC	WLS

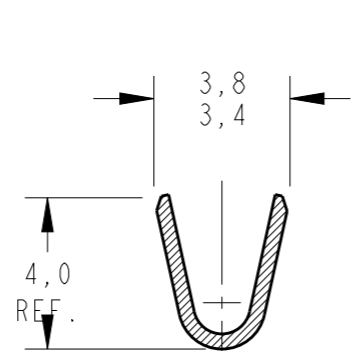
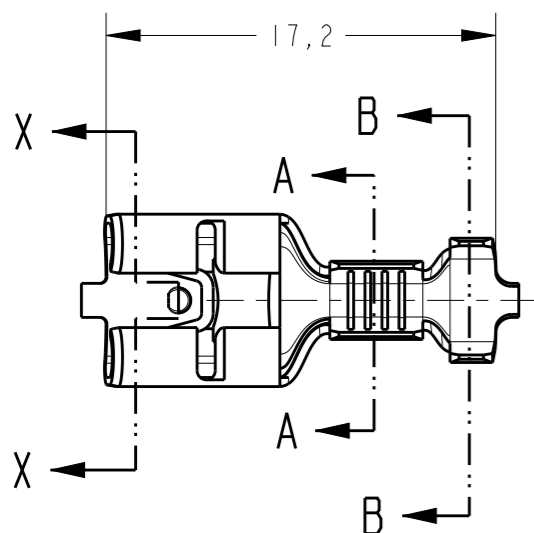

SECTION A-A SCALE 5:1

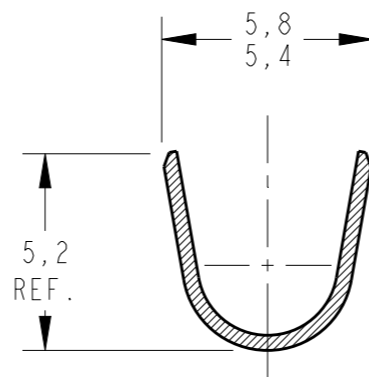

SECTION B-B SCALE 5:1

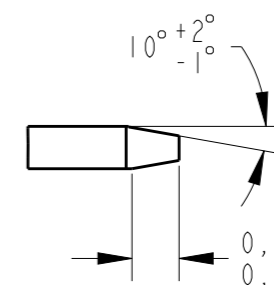

DETAIL Y SCALE 7:1

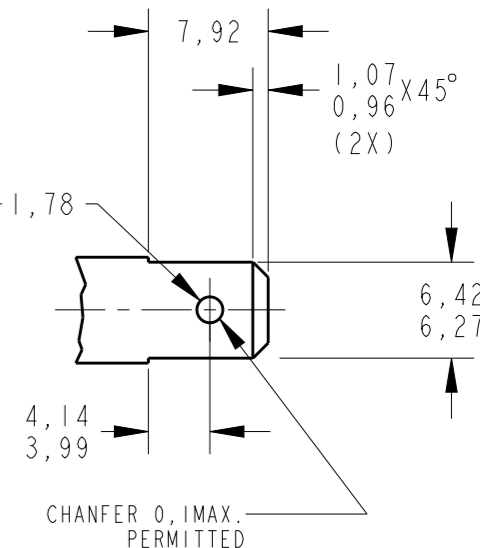

TEST TAB BR-6-058-1 MATERIAL: AÇO RÁPIDO

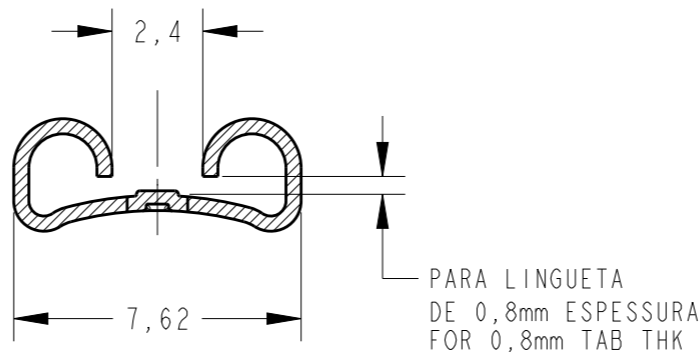
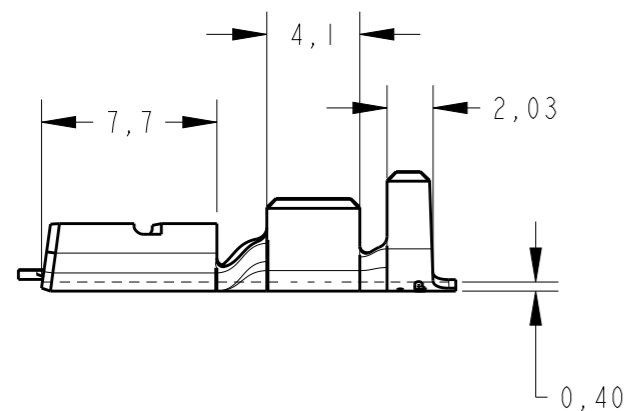
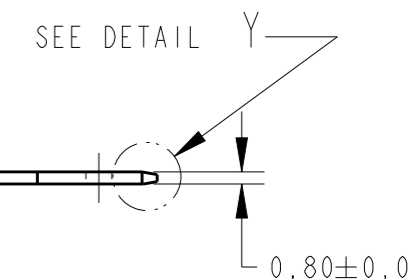

SECTION X-X SCALE 5:1

ESTANHADO / TIN PLATED	LATÃO / BRASS	444335 -4
—	LATÃO / BRASS	444335 -3
ESTANHADO / TIN PLATED	LATÃO / BRASS	444335 -2
—	LATÃO / BRASS	444335 -1
FINISH	MATERIAL	PART NUMBER

INS. RANGE	WIRE RANGE
∅ 3,0-4,3mm	1,0-2,5mm <sup>2</sup>

THIS DRAWING IS A CONTROLLED DOCUMENT.

DIMENSIONS: mm

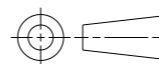

TOLERANCES UNLESS OTHERWISE SPECIFIED:

0 PLC	±0,3
1 PLC	±0,3
2 PLC	±0,3
3 PLC	±0,3
4 PLC	±0,3
ANGLES	±1°

MATERIAL - FINISH -

DWN NCLAPRESA 12JUL2012  
 CHK JRGOLDSCHMIDT 12JUL2012  
 APVD DAOLIVEIRA 12JUL2012

PRODUCT SPEC 108-37034  
 APPLICATION SPEC -

WEIGHT -

Customer Drawing

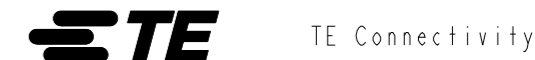

TERMINAL FASTON 6,5 RECEPT

SIZE	CAGE CODE	DRAWING NO	RESTRICTED TO
A3	00779	444335	-

SCALE	SHEET	OF	REV
3:1	1	1	D4

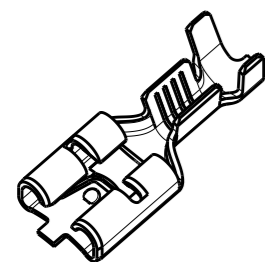

PERSPECTIVE VIEW SCALE 2:1

PART NUMBER	1° INSERÇÃO MÁX. (N)	1° EXTRAÇÃO MIN. (N)	10° EXTRAÇÃO MIN. (N)
444335 -1	40	50	20
444335 -2	40	50	20
444335 -3	40	70	20
444335 -4	40	70	20