

THIS DRAWING IS UNPUBLISHED. RELEASED FOR PUBLICATION, 19  
 © COPYRIGHT 19 BY AMP INCORPORATED, HARRISBURG, PA. ALL INTERNATIONAL RIGHTS RESERVED. AMP PRODUCTS MAY BE COVERED BY U.S. AND FOREIGN PATENTS AND/OR PATENTS PENDING.

LOC	DIST	P	F	ZONE	LTR	DESCRIPTION	DATE	APPROVED
AJ	16				G	REV PER 0514-0177-02	20FEB03	JGH

- 1 BERYLLIUM COPPER PER ASTM-B-196
- 2 STAINLESS STEEL PER ASTM-A-582
- 3 PTFE PER ASTM-D-1710
- 4 STEEL WIRE PER QQ-W-470
- 5 BRASS PER ASTM-B-16
- 6 GOLD PL PER MIL-G-45204
- 7 PASSIVATION PER QQ-P-35
- 8 NICKEL PL PER QQ-N-290
- 9 .190 MAX PANEL THICKNESS
- 10 .060 MAX FLOAT PERMITTED DUE TO INTERNAL SPRING
- 11 BOILLAT B05 PER UNS 53800

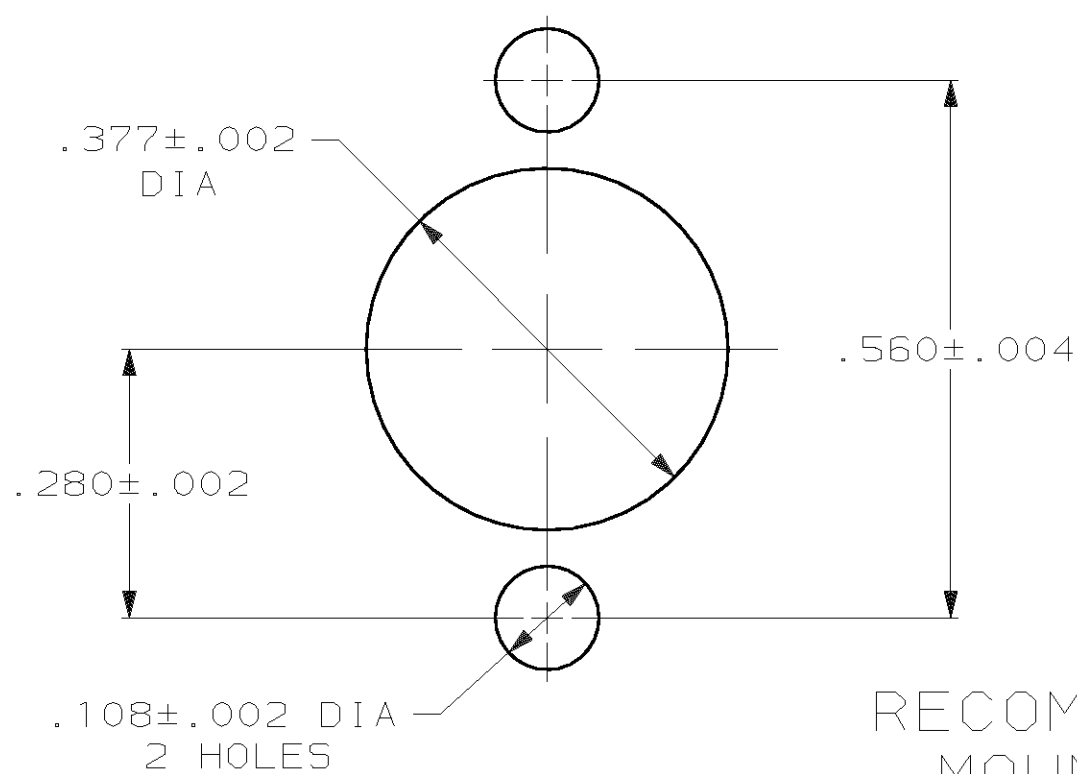
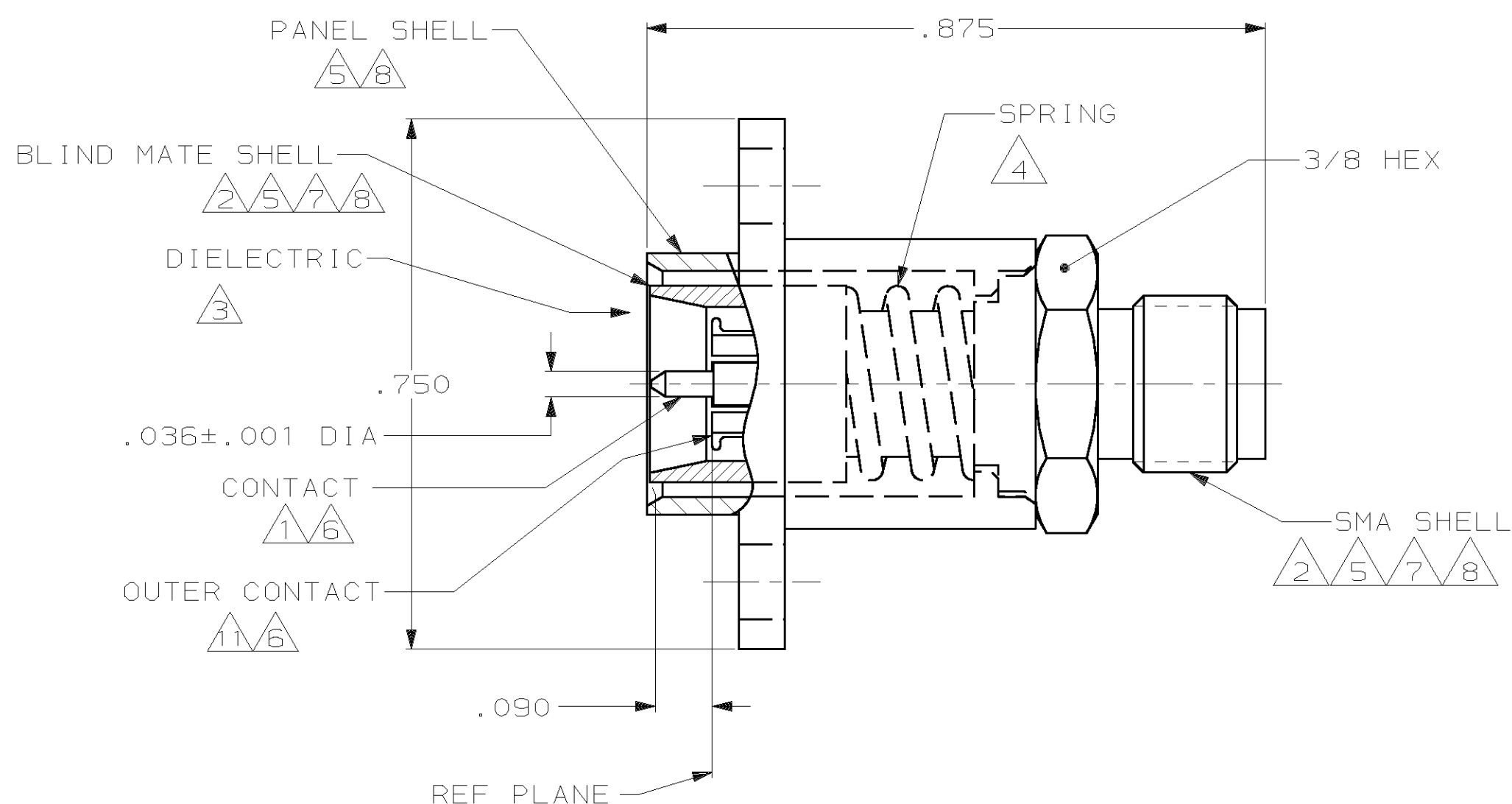

RECOMMENDED MOUNTING HOLES

SUPSD BY 448091-2

2, 7	448091-2
5, 9	448091-1
SMA SHELL MAT'L/FINISH	PART NUMBER

UNLESS OTHERWISE SPECIFIED DIMENSIONS ARE IN INCHES TOLERANCES ON:		DR S. BURKHOLDER 14MAY98		AMP INCORPORATED Harrisburg, Pa. 17105	
2 PL DEC ±		CHK J. HAVENER 14MAY98			
3 PL DEC ± .005		APPD S. BURKHOLDER 14MAY98		NAME	
ANGLES ±		APPD J. HAVENER 14MAY98		ADAPTER, PLUG, FLOATING, 3.5MM BLIND MATE, TO JACK, SMA	
MATERIAL		PRODUCT SPEC		SIZE	
1 THRU 5 & 11		APPLICATION SPEC		C 00779	
FINISH		WEIGHT		DRAWING NO	
6 THRU 8				448091	
				SCALE 5:1	
				SHEET 1 OF 1	