

REVISIONS					
P	LTR	DESCRIPTION	DATE	DMN	APVD
B2	REVISED PER	ECR-15-016187	16DEC2015	LN	RS

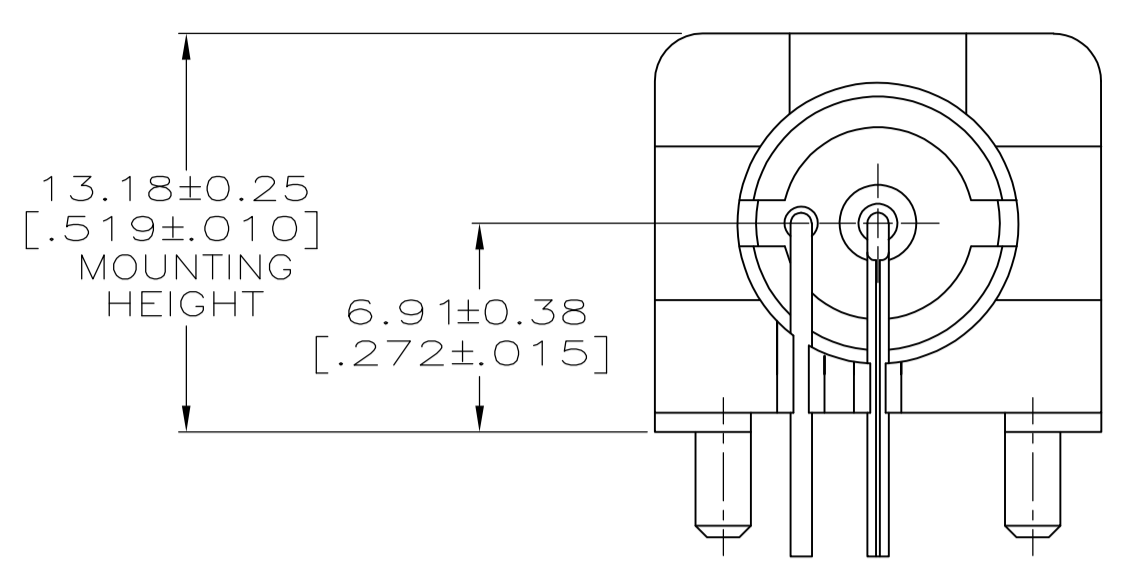

VIEW C
 (SAME AS VIEW A
 EXCEPT AS SHOWN)

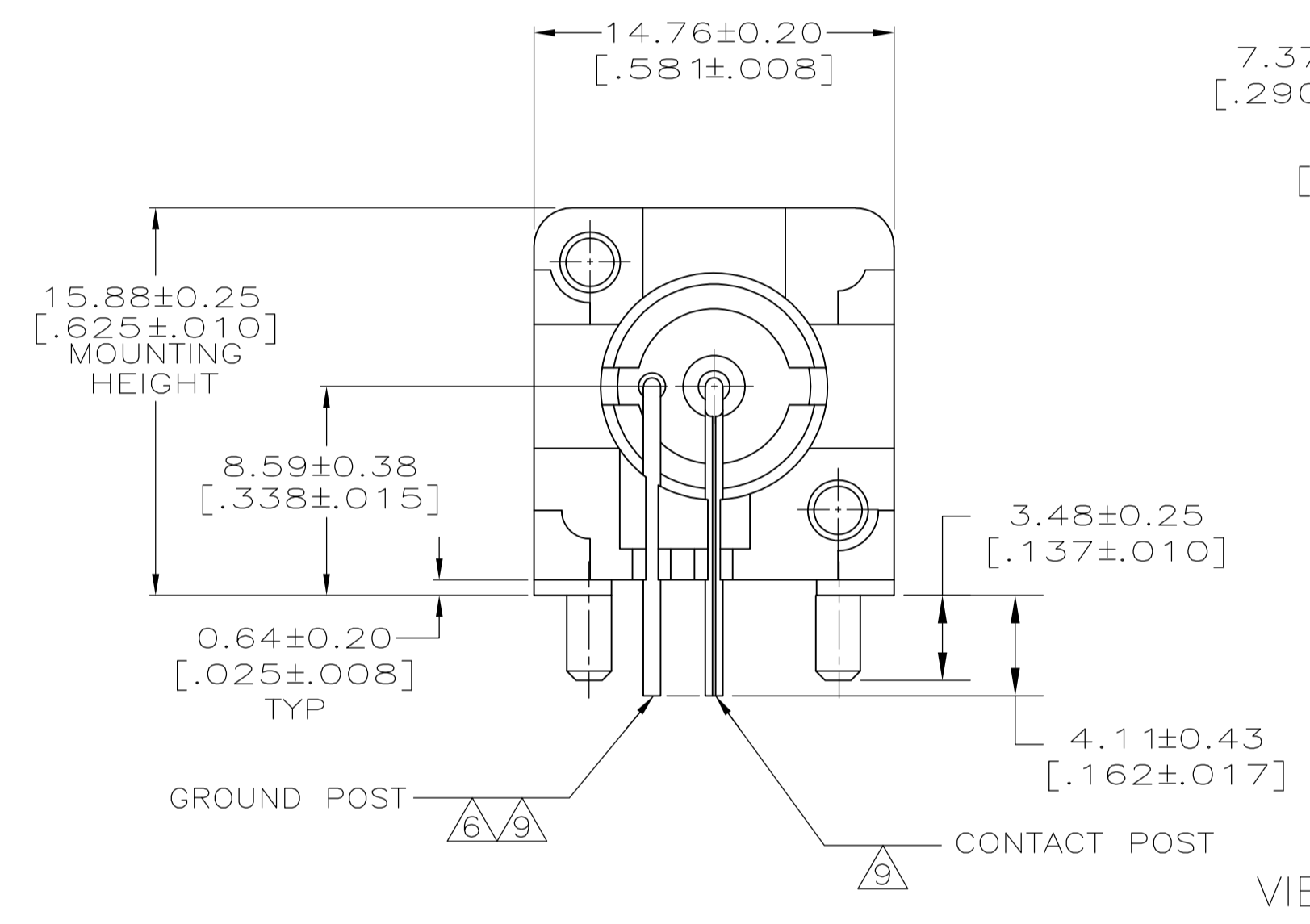
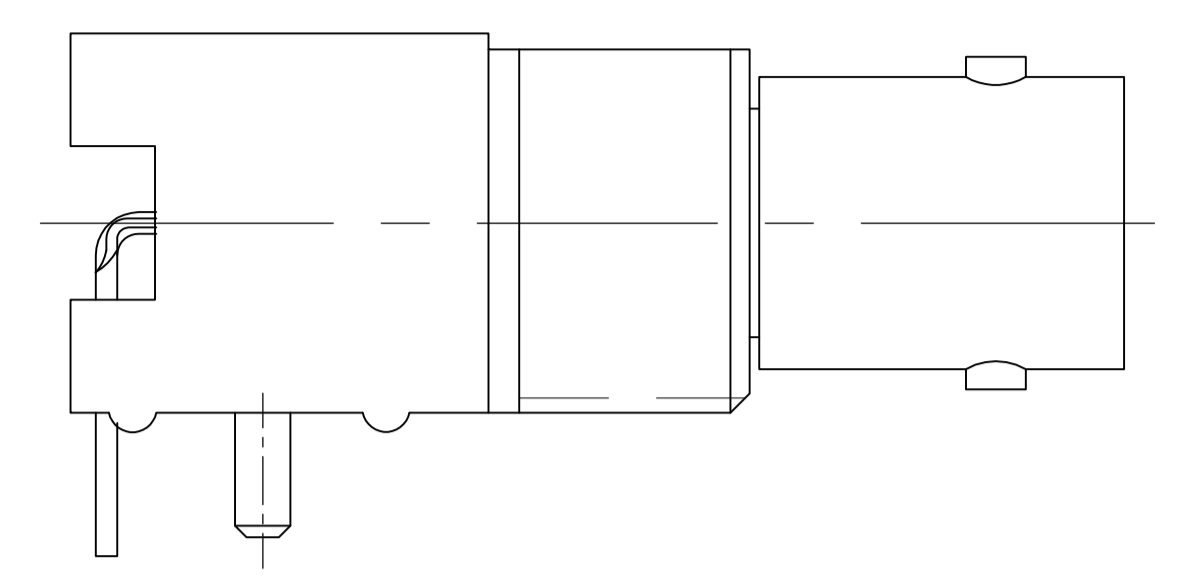

VIEW A

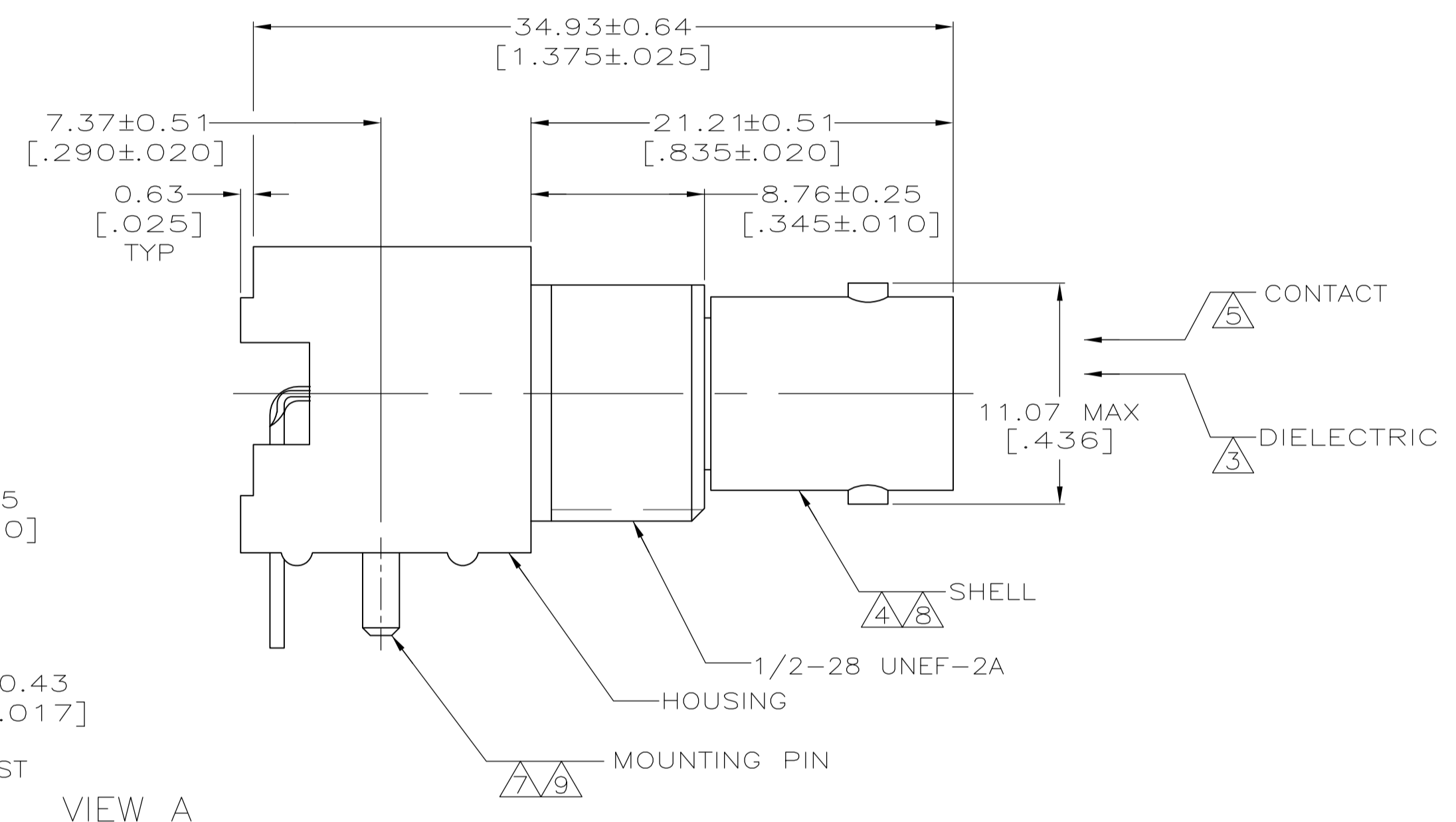

- 1 POLYESTER PBT PER MIL-M-24519, TYPE GPT-15F, UL94V-O RATED, COLOR:WHITE
- 2 POLYESTER PBT PER MIL-M-24519, TYPE GPT-15F, UL94V-O RATED, COLOR:BLACK
- 3 POLYMETHYLPENTENE, GENERAL PURPOSE.
- 4 ZINC PER QQ-Z-363.
- 5 PHOSPHOR BRONZE PER QQ-B-750.
- 6 BRASS PER ASTM-B-453.
- 7 BRASS PER ASTM-B-16.
- 8 NICKEL PLATE PER QQ-N-290, 3.81 μm [.000150] MINIMUM THICK.
- 9 TIN PLATE PER ASTM-B-545, 3.81 μm [.000150] MINIMUM THICK.
- 10 GOLD PLATE PER MIL-G-45204, 0.76 μm [.000030] MINIMUM THICK.
- 11 GOLD PLATE PER MIL-G-45204, 1.27 μm [.000050] MINIMUM THICK.
- 12. SEE INSTRUCTION SHEET 408-2769.
- 13. RECOMMENDED TORQUE FOR NUT(part 2) : 0.9 Nm.

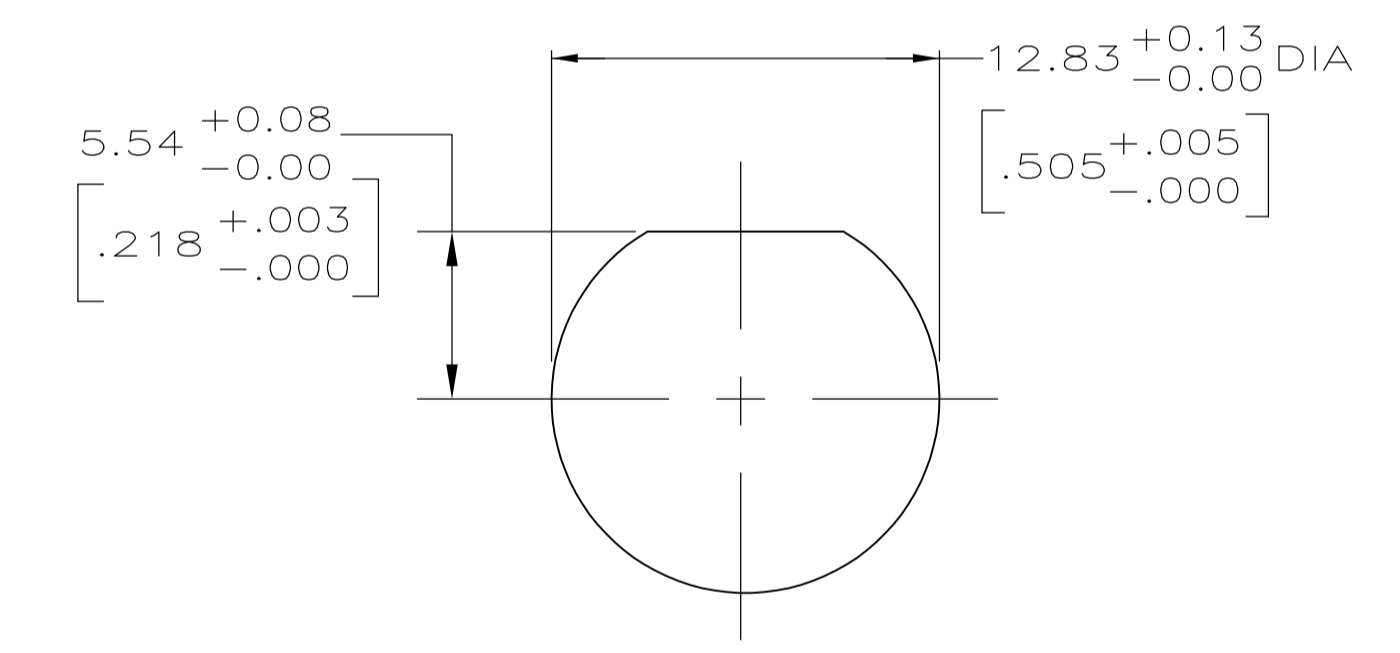

RECOMMENDED PANEL CUTOUT

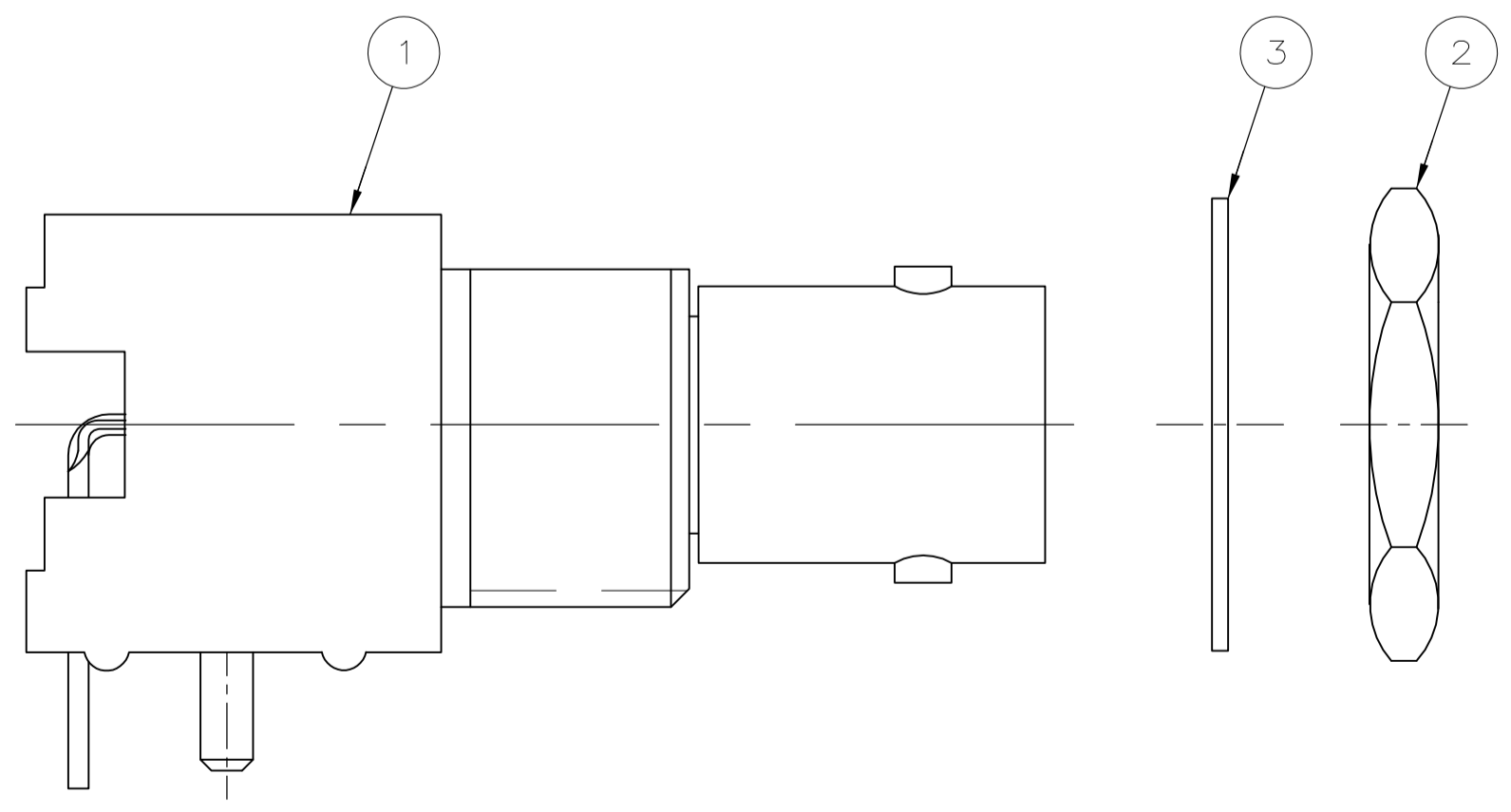

VIEW B

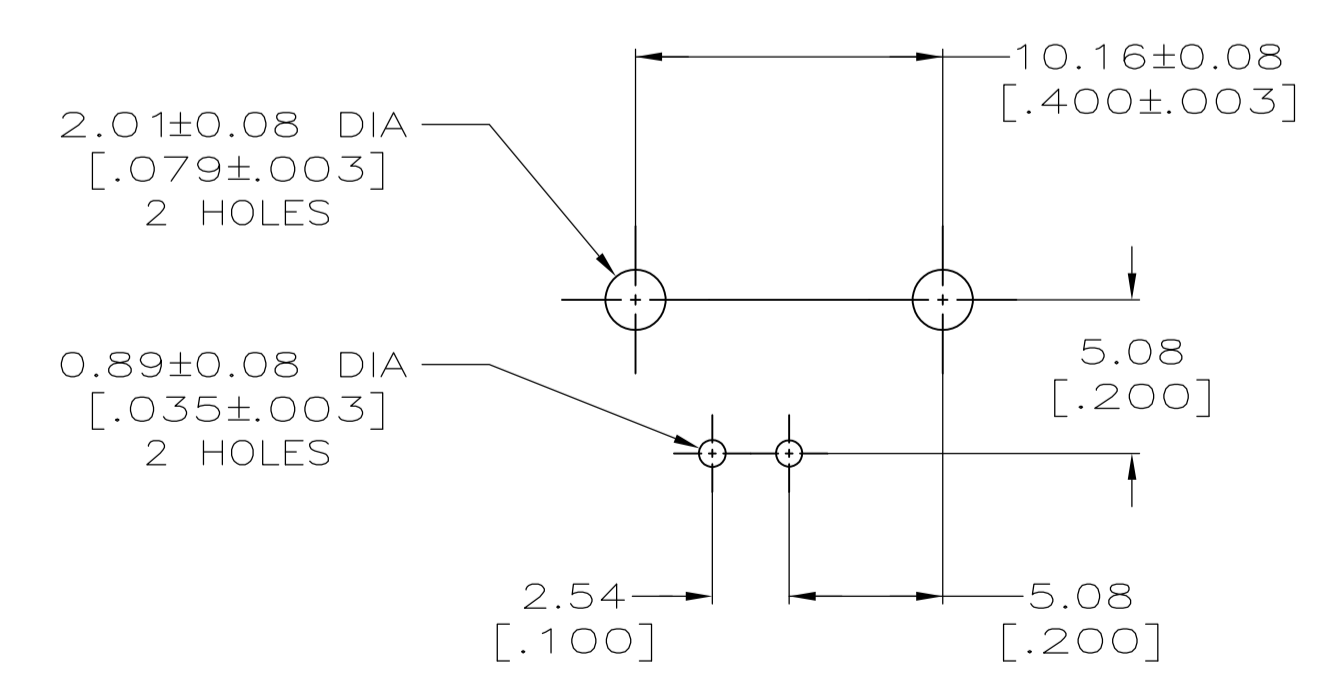

PCB CONFIGURATION

-	-	B	1-329632-2	1-329631-2	5227161-9	1-5227161-7
-	-	B	1-329632-2	1-329631-2	5227161-6	1-5227161-6
1	1	C	-	-	-	1-5227161-5
2	2	C	-	-	-	5227161-9
3	3	C	-	-	-	5227161-7
4	4	A	-	-	-	5227161-6
5	5	A	-	-	-	5227161-3
6	6	A	-	-	-	5227161-2
7	7	A	-	-	-	5227161-1
CONTACT FINISH	HOUSING MATERIAL	VIEW	3 LOCKWASHER	2 JAM NUT QTY=1	1 ASSEMBLY QTY=1	PART NUMBER

THIS DRAWING IS A CONTROLLED DOCUMENT.

DIMENSIONS: INCHES	TOLERANCES UNLESS OTHERWISE SPECIFIED:	DIN L. VARELA - 20APR2005	TE Connectivity
0 PL ± -	1 PL ± -	CHK J. HAVENER 20APR2005	NAME S. BURKHOLDER
2 PL ± 0.05 [.002]	3 PL ± -	APVD S. BURKHOLDER 20APR2005	PRODUCT SPEC 108-12078
4 PL ± -	ANGLES ± -	SIZE	CAGE CODE DRAWING NO
MATERIAL	FINISH	WEIGHT	A1 00779 C=5227161
CUSTOMER DRAWING		SCALE 4:1	SHEET 1 OF 1 REV B2