

THIS DRAWING IS UNPUBLISHED. RELEASED FOR PUBLICATION
 © COPYRIGHT - By - ALL RIGHTS RESERVED.

LOC	DIST	REVISIONS					
AF	50	P	LTR	DESCRIPTION	DATE	DWN	APVD
			K	REVISED PER ECR-12-013459	28NOV2012	KH	PD

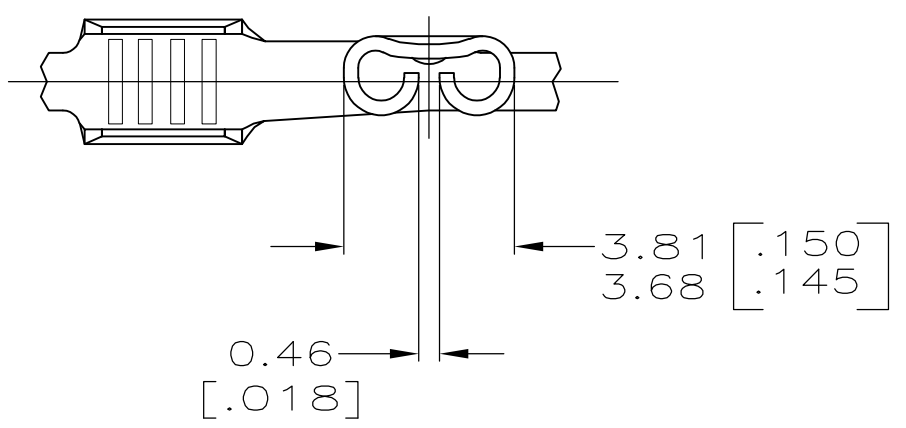

- 1 CONTINUOUS STRIP ON REELS.
- 2 PART MUST BE REELED ON TO PLASTIC REELS.
- 3 PRELIMINARY - NOT FOR PRODUCTION

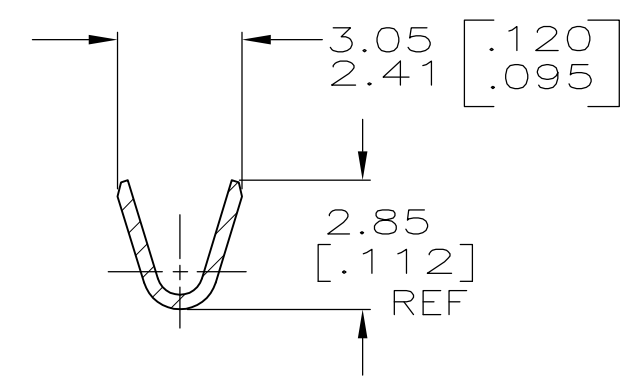
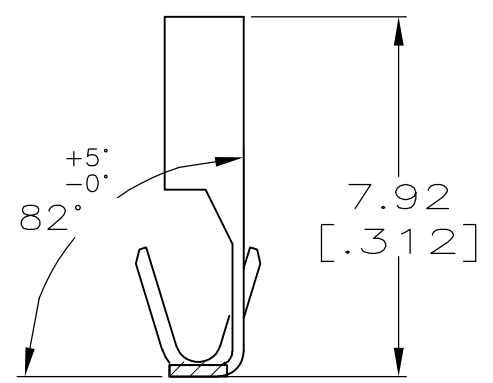
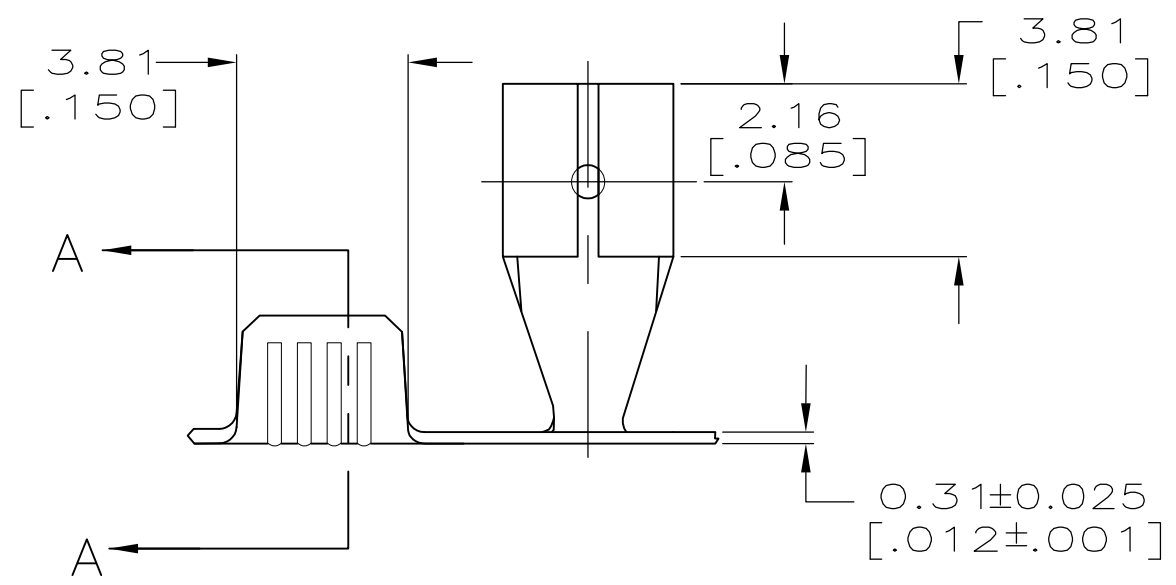

3 2	[#22-#16] AWG	0.51±0.025 [.020±.001]	60991-3
	[#22-#16] AWG	0.51±0.025 [.020±.001]	60991-1
	WIRE SIZE	MATING TAB THICKNESS	PART NO

4.77 [.188]	F	2.03 [.080]	1.52 [.060]	16
			1.32 [.052]	18
			1.19 [.047]	20
			1.11 [.044]	22
STRIP LENGTH ±0.38 [.015]	TYPE	WIDTH	±0.051 [.002] HEIGHT	WIRE
WIRE BARREL CRIMP				

THIS DRAWING IS A CONTROLLED DOCUMENT.

DIMENSIONS: mm [INCHES]	TOLERANCES UNLESS OTHERWISE SPECIFIED:
	0 PLC ± -
	1 PLC ± -
	2 PLC ± 0.25 [.010]
	3 PLC ± -
4 PLC ± -	± -
ANGLES	± -
FINISH	-

MATERIAL: BRASS

DWN JR RUTH 4/3/95	TE Connectivity	NAME		
CHK MS FEHER 4/3/95		RECEPTACLE, FASTON, 2.79 [.110] SERIES		
APVD P DESANTIS 4/3/95		PRODUCT SPEC	APPLICATION SPEC	RESTRICTED TO
114-2028		114-2028	114-2028	-
WEIGHT -	SIZE A3	CAGE CODE 00779	DRAWING NO C-60991	
CUSTOMER DRAWING	SCALE 6:1	SHEET 1 OF 1	REV K	