

THIS DRAWING IS UNPUBLISHED. RELEASED FOR PUBLICATION .19  
 © COPYRIGHT 19 BY AMP INCORPORATED. ALL RIGHTS RESERVED.

LOC	DIST	REVISIONS				
P	LTR	DESCRIPTION	DATE	DWN	APVD	
DY	-	B REVISED PER ECO-17-005660	21APR2017	BJ	SY	

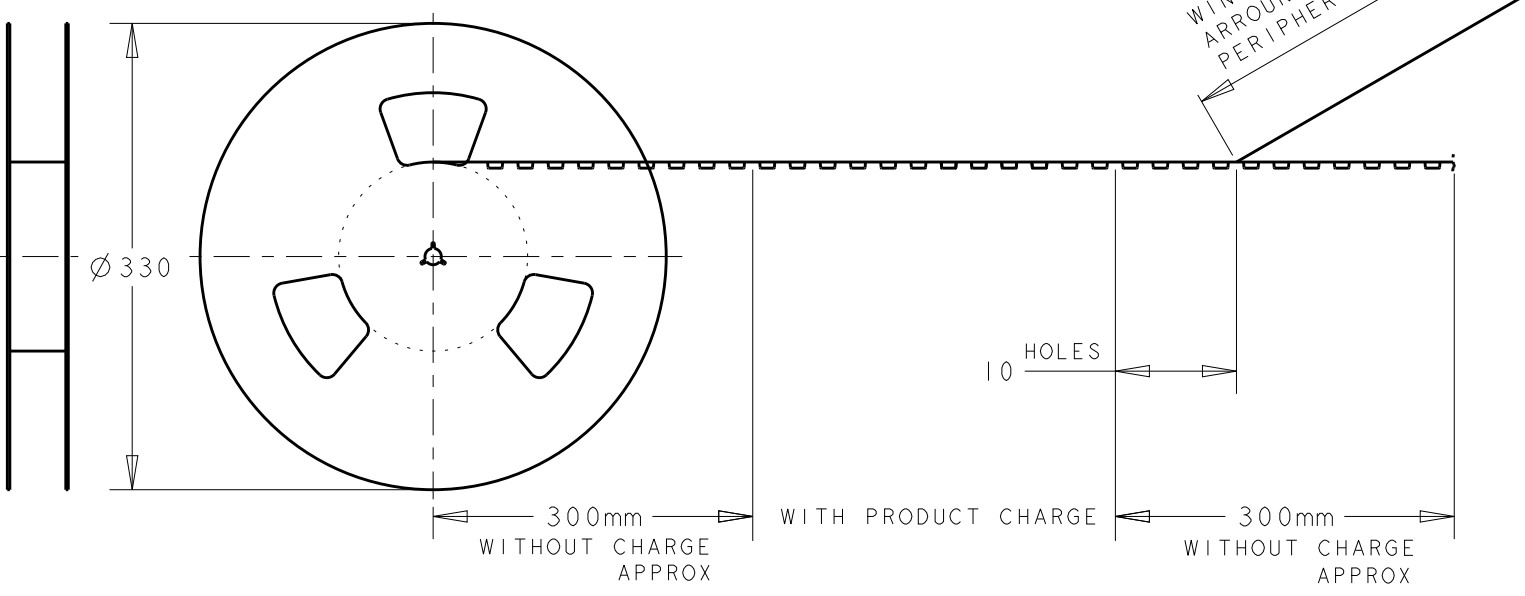
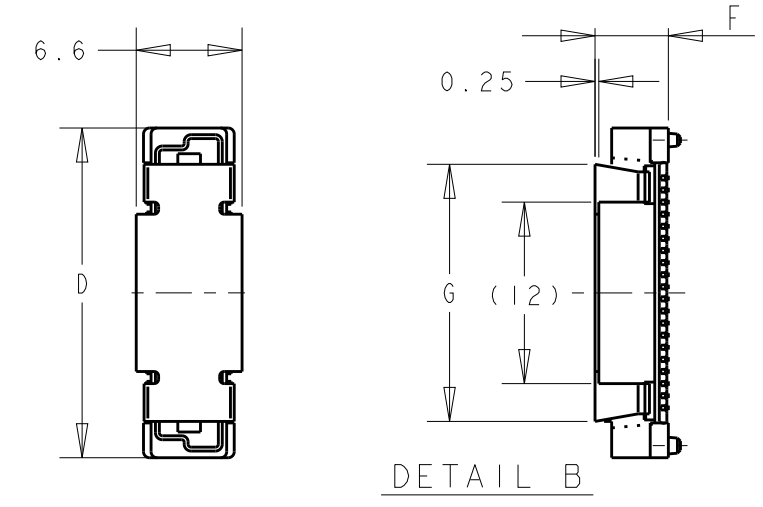
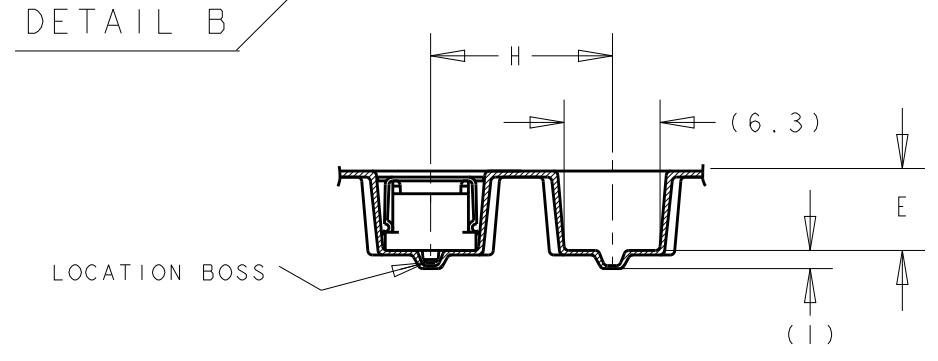
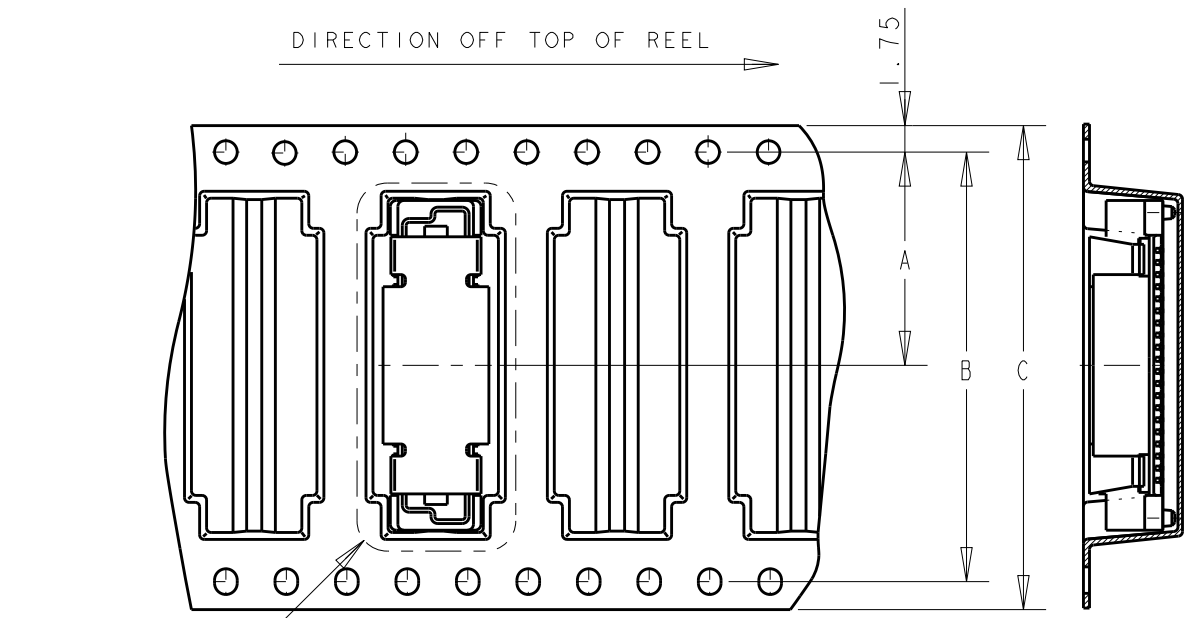

AVAILABLE	600	▲	12	▲	▲	▲	29.8	44	40.4	20.2	60	2-	▲	-1
	▲		▲				85.8	▲	▲	▲	200	1-		-0
							77.8	104	100.4	50.2	180			-9
							69.8	▲	▲	▲	160			-8
							61.8	88	84.4	42.2	140			-6
							53.8	▲	▲	▲	120			-5
	400		16				45.8	72	68.4	34.2	100			-4
	▲		▲				37.8	56	52.4	26.2	80			-3
						29.8	44	40.4	20.2	60			-2	
TOOLING STATUS	POS	HEIGHT TYPE	H	G	F	E	D	C	B	A	POS	PART NO.		
	600	8H	12	17	7.85	8.6	21.8	32	28.4	14.2	40	6123001-1		

NOTE:  
 5 CONNECTOR WITH BLACK HOUSING.  
 LOW HALOGEN

THIS DRAWING IS A CONTROLLED DOCUMENT FOR AMP INCORPORATED. IT IS SUBJECT TO CHANGE AND THE CONTROLLING ENGINEERING ORGANIZATION SHOULD BE CONTACTED FOR THE LATEST REVISION.		DWN WYLEE 27OCT04 CHK VINCENT TAN APVD ERIC ING PRODUCT SPEC 108-5390 APPLICATION SPEC - WEIGHT -	<b>AMP</b> Tyco Electronics Singapore Pte. Ltd.
DIMENSIONS: mm 	TOLERANCES UNLESS OTHERWISE SPECIFIED: 0 PLC ±0.2 1 PLC ±0.25 2 PLC ±0.30 3 PLC ±0.000J 4 PLC ±3 ANGLES	NAME EMBOSS ASSY FOR FH 0.8BTB CONNECTOR PLUG 8H 0.5 BOSS LENGTH (0.76um GOLD)	SIZE A3 CAGE CODE 00779 DRAWING NO ©=6123001
MATERIAL -	FINISH -	CUSTOMER DRAWING	SCALE 2:1 SHEET 1 OF 2 REV B

LOC		DIST		REVISIONS		
P	LTR	DESCRIPTION	DATE	DWN	APVD	
		SEE SHEET 1				

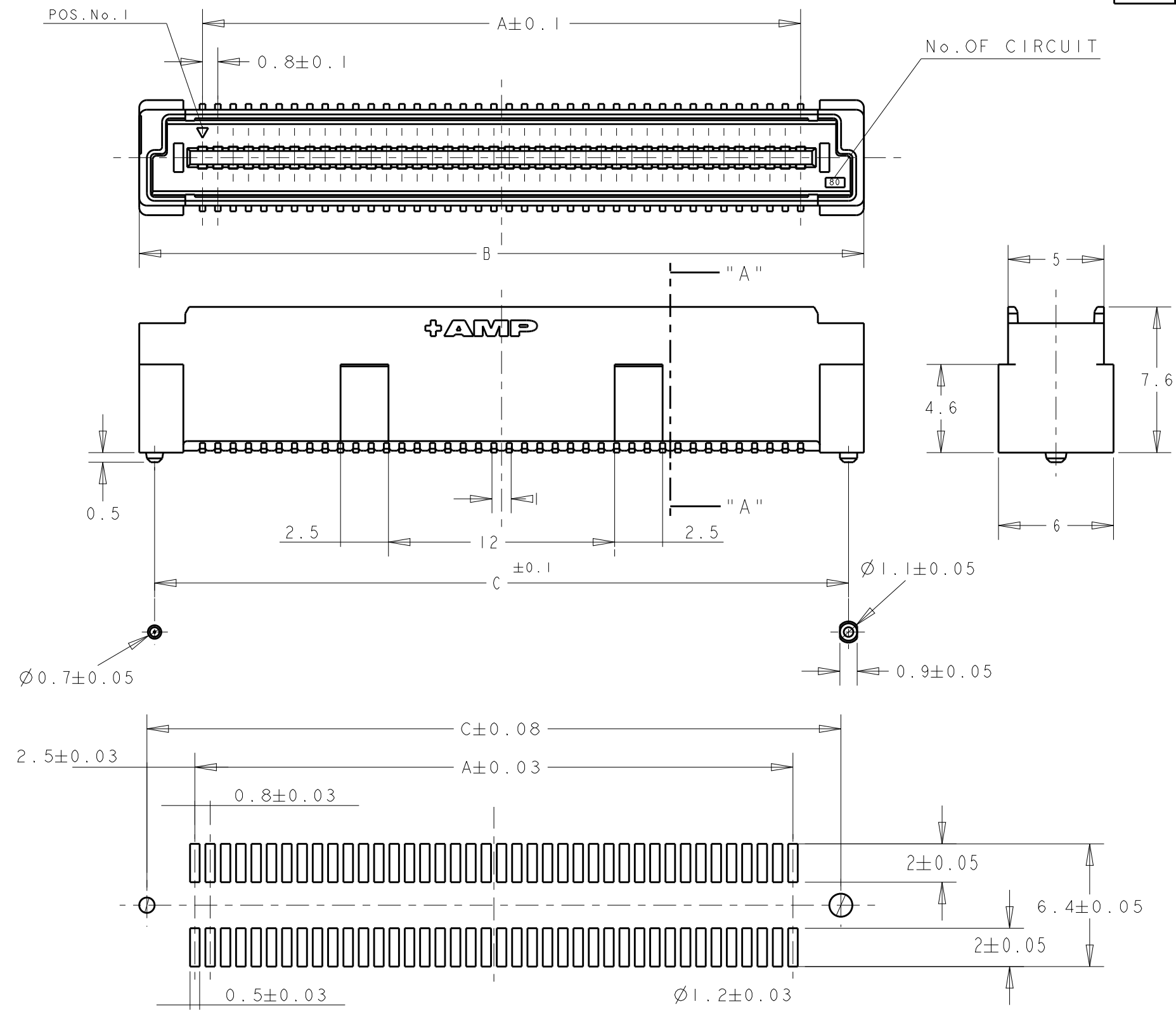

- NOTES:
- MATERIAL:  
HOUSING: L.C.P. (HIGH TEMP. THERMOPLASTIC)  
UL 94V-0, NATURAL.  
CONTACT: BRASS.
  - FINISH:  
CONTACT AREA: 0.00076 MIN GOLD ON  
0.0013 MIN ALL OVER NICKEL.  
SOLDERING AREA: 0.002 MIN MATTE-TIN.
  - POSITION SERIES: SEE TABLE.
  - CONN STACK HEIGHT COMBINE OF PLUG "Y" H VS REC "X" H.  
STACK HEIGHT = Y + X - 5

$\phi 0.8 \pm 0.03$  RECOMMENDED P.C. BOARD LAYOUT

**LOW HALOGEN**

THIS DRAWING IS A CONTROLLED DOCUMENT FOR AMP INCORPORATED. IT IS SUBJECT TO CHANGE AND THE CONTROLLING ENGINEERING ORGANIZATION SHOULD BE CONTACTED FOR THE LATEST REVISION.		DWN WYLEE 27OCT04	<b>AMP</b>
DIMENSIONS: mm		CHK VINCENT TAN	
TOLERANCES UNLESS OTHERWISE SPECIFIED: 0 PLC ± 1 PLC ±0.2 2 PLC ±0.25 3 PLC ±0.30 4 PLC ± ANGLES ±3°		APVD ERIC ING	NAME EMBOSS ASSY FOR FH 0.8BTB CONNECTOR PLUG 8H 0.5 BOSS LENGTH (0.76um GOLD)
MATERIAL material_2		PRODUCT SPEC 108-5390	SIZE A3
FINISH finish_spec_2		APPLICATION SPEC -	CAGE CODE 00779
		WEIGHT -	DRAWING NO 6123001
		CUSTOMER DRAWING	SCALE 2:1
			SHEET 2 OF 2
			REV B