

THIS DRAWING IS UNPUBLISHED. RELEASED FOR PUBLICATION
 © COPYRIGHT BY TYCO ELECTRONICS CORPORATION. ALL RIGHTS RESERVED.

LOC	DIST	REVISIONS			
P	LTR	DESCRIPTION	DATE	DWN	APVD
AF	50	L1	ECR-06-023927(REDRAWN IN AUTOCAD)	27JUN06	HMR GP

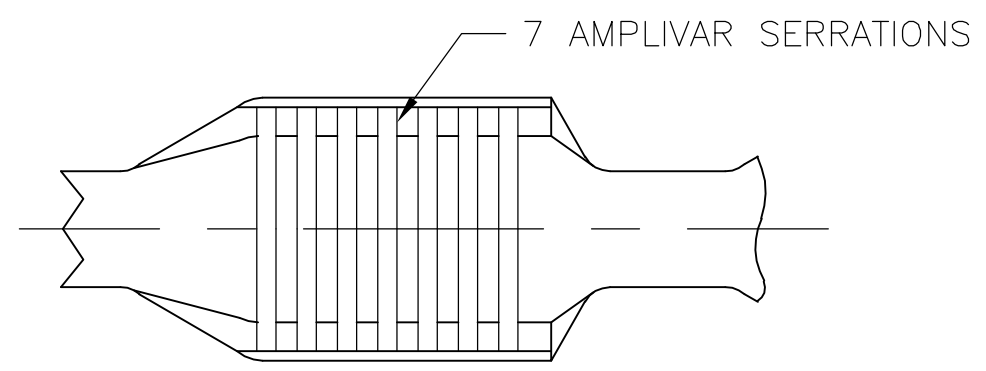

- CONTINUOUS STRIP ON REELS.
- DIMENSIONS IN BRACKETS ARE IN INCHES.
- FOR ADDITIONAL INFORMATION, SEE APPLICATION SPEC. 114-2002.
- CRIMP WIDTH: .110 F TYPE (AMPLIVAR PIGTAIL)
 CRIMP HEIGHT (±.002)=(TOTAL CMA+9,400)/190,500
 GENERAL APPLICATION GUIDELINES MUST BE FOLLOWED AS SPECIFIED IN CATALOG #82221
 FOR APPLICATOR INFORMATION CALL:1-800-722-1111
 FOR PRODUCT INFORMATION CALL:1-800-522-6752

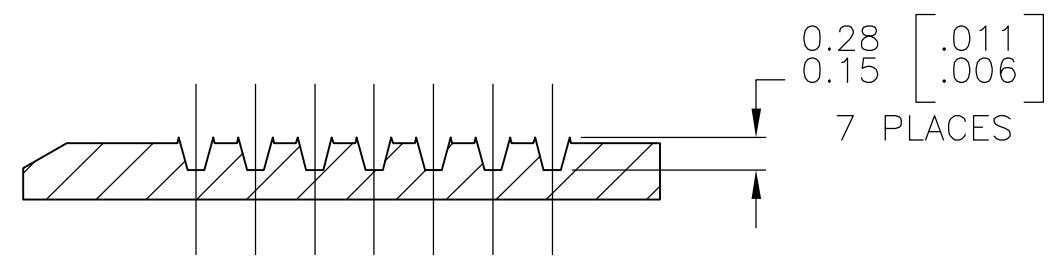
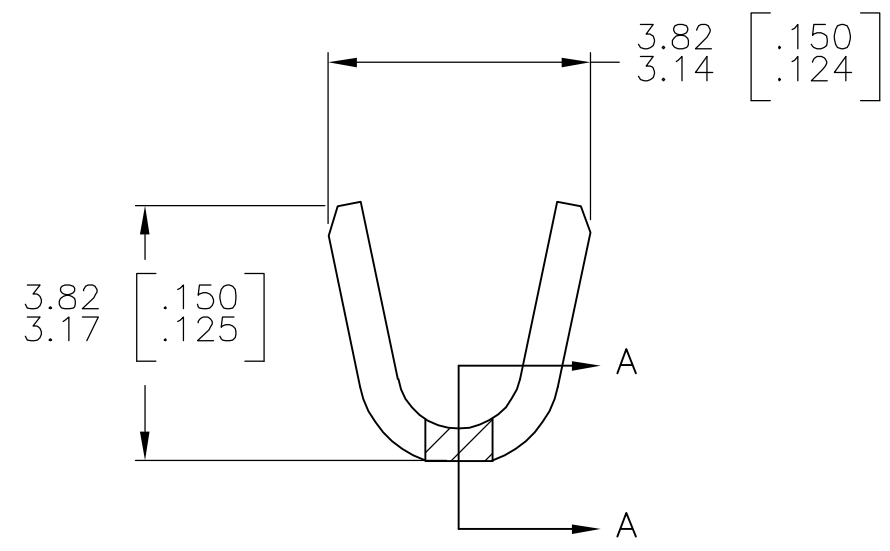
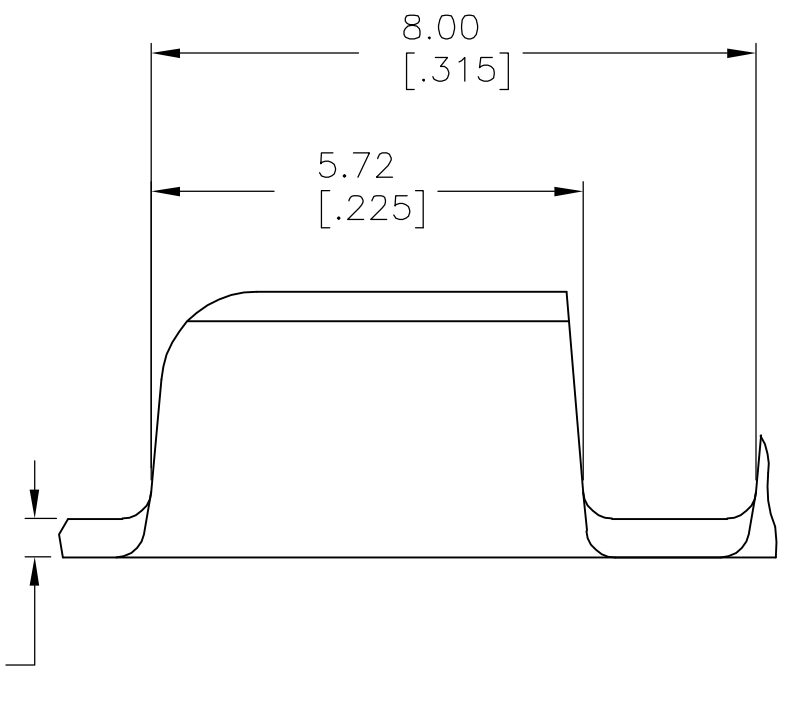

SECTION A-A
 SCALE 20:1

TIN PLATE	62000-2
-	62000-1
FINISH	PART NO

THIS DRAWING IS A CONTROLLED DOCUMENT.		DWN RAGHAVENDRA 27JUN06	Tyco Electronics Corporation Harrisburg, PA 17105-3608	
DIMENSIONS: mm [INCHES]	TOLERANCES UNLESS OTHERWISE SPECIFIED:	CHK G.D.PORTA	NAME	
	0 PLC ± -	APVD G.D.PORTA	SPLICE, AMPLIVAR	
	1 PLC ± -	PRODUCT SPEC	600-3000 CMA	
	2 PLC ± -	APPLICATION SPEC	SIZE	CAGE CODE
	3 PLC ± 0.38 [.015]	FINISH	DRAWING NO	
4 PLC ± -	SEE TABLE	RESTRICTED TO		
MATERIAL BRASS	FINISH SEE TABLE	WEIGHT -	A3 00779	C=62000
CUSTOMER DRAWING			SCALE 10:1	SHEET 1 OF 1
			REV L1	