

THIS DRAWING IS UNPUBLISHED. RELEASED FOR PUBLICATION
 © COPYRIGHT BY TYCO ELECTRONICS CORPORATION. ALL RIGHTS RESERVED.

LOC	DIST	REVISIONS					
AF	50	P	LTR	DESCRIPTION	DATE	DWN	APVD
			D4	REVISED PER ECR-08-018166	29JUL08	HMR	EH

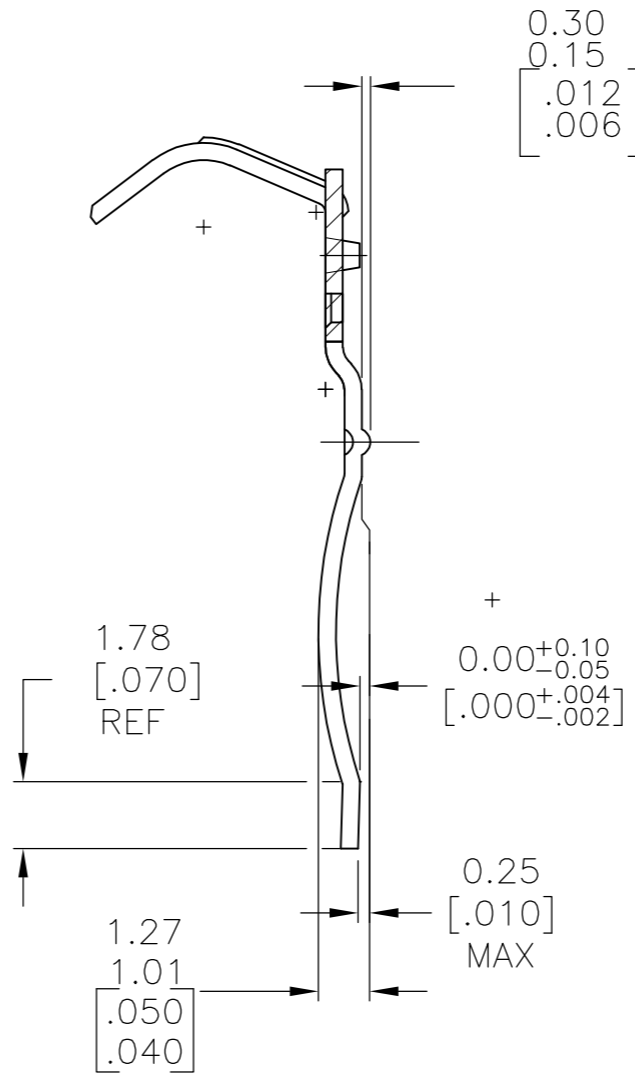

- 1 PRODUCT PROVIDED IN STRIP FORM ON SPLICE FREE REELS.
- 2 REVERSE REEL OF 62008-1 AND 62008-2.
- 3 PRE-PRODUCTION - FASR REQUIRED
- 4 SAME AS 62009-1 EXCEPT SPECIAL PACKAGING FOR INTERNATIONAL SHIPMENT

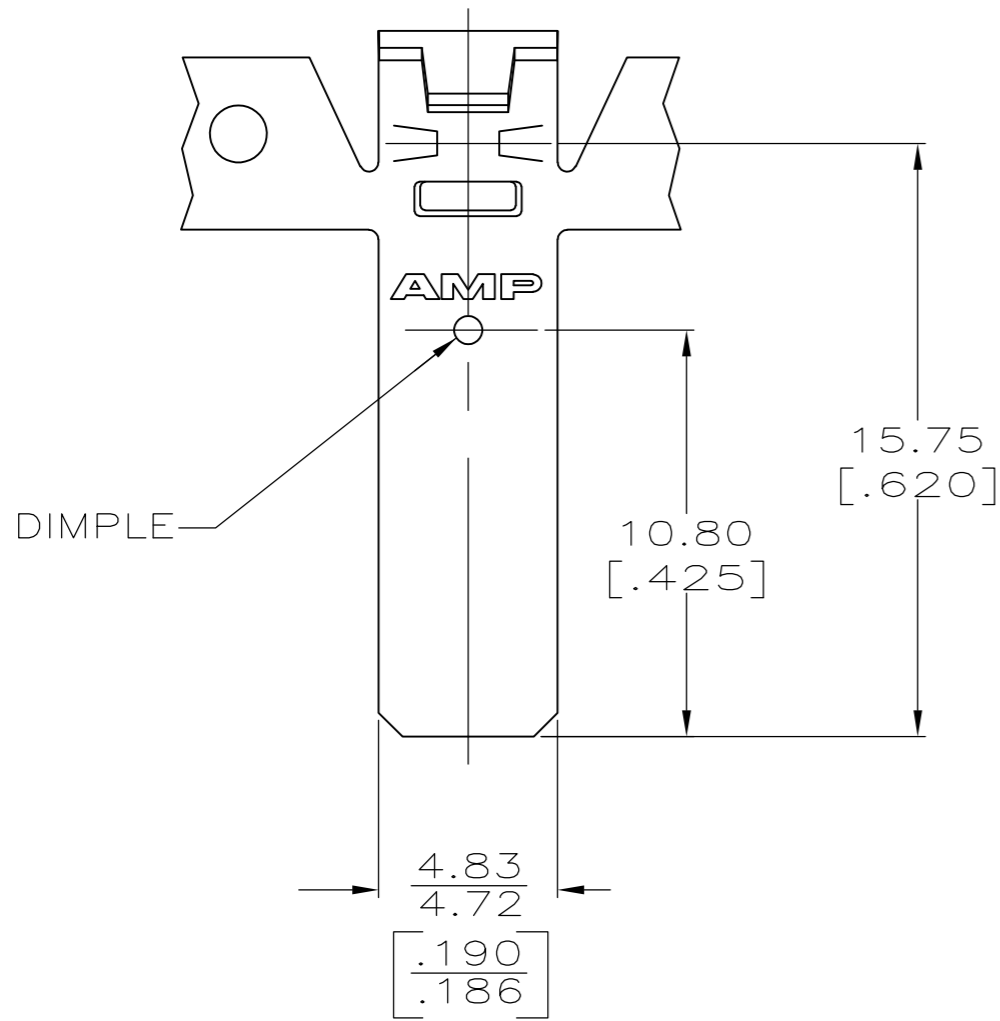
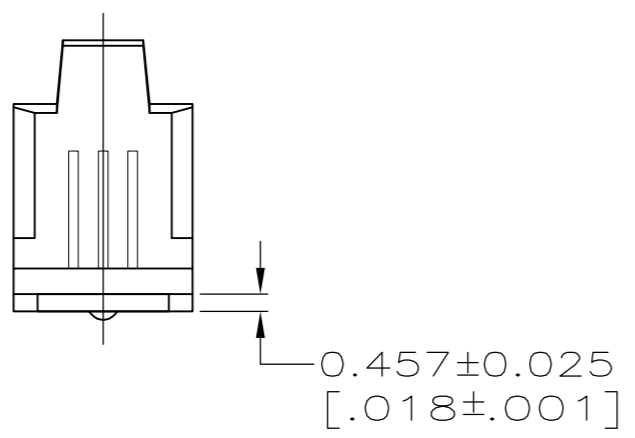

0.00203[.000080] MIN TIN		20-14 AWG	4	62009-5
0.00381[.000150] MIN SILVER			3	62009-4
FINISH		WIRE RANGE	2	62009-2
THIS DRAWING IS A CONTROLLED DOCUMENT.			2	62009-1
DWN 29JAN1999 PHILLIP M FORTNEY		Tyco Electronics Corporation Harrisburg, PA 17105-3608	PART NUMBER	
CHK 29JAN1999 JEFF R RUTH			NAME	
APVD 29JAN1999 DON DECKER		BRUSH CONTACT, TAB-LOCK LEFT HAND		
DIMENSIONS: mm [INCHES]		SIZE CAGE CODE DRAWING NO RESTRICTED TO		
TOLERANCES UNLESS OTHERWISE SPECIFIED:		A3 00779 C-62009		
0 PLC ± -		CUSTOMER DRAWING SCALE 5:1 SHEET 1 OF 1 REV D4		
1 PLC ± -				
2 PLC ± 0.25[.010]				
3 PLC ± -				
4 PLC ± -				
ANGLES ± -				
MATERIAL T3 PHOS BRONZE				
FINISH SEE TABLE				