

THIS DRAWING IS UNPUBLISHED. RELEASED FOR PUBLICATION
 © COPYRIGHT - TE Connectivity Ltd. ALL RIGHTS RESERVED.

REVISIONS					
P	LTR	DESCRIPTION	DATE	DWN	APVD
	C1	REVISED PER ECR-18-000956	2018-1-24	ST	TD

1 CONTINUOUS STRIP ON REELS.
 2 .001905 [.000075] MIN PRE-NICKEL PER QQ-N-290.

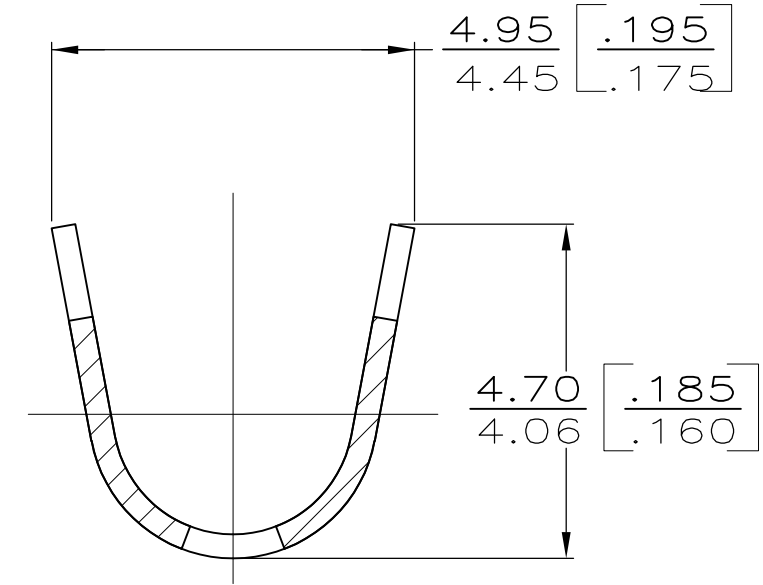
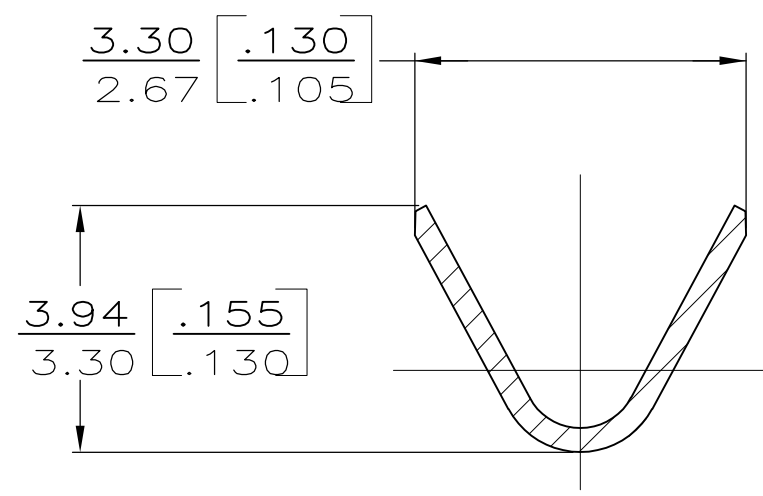
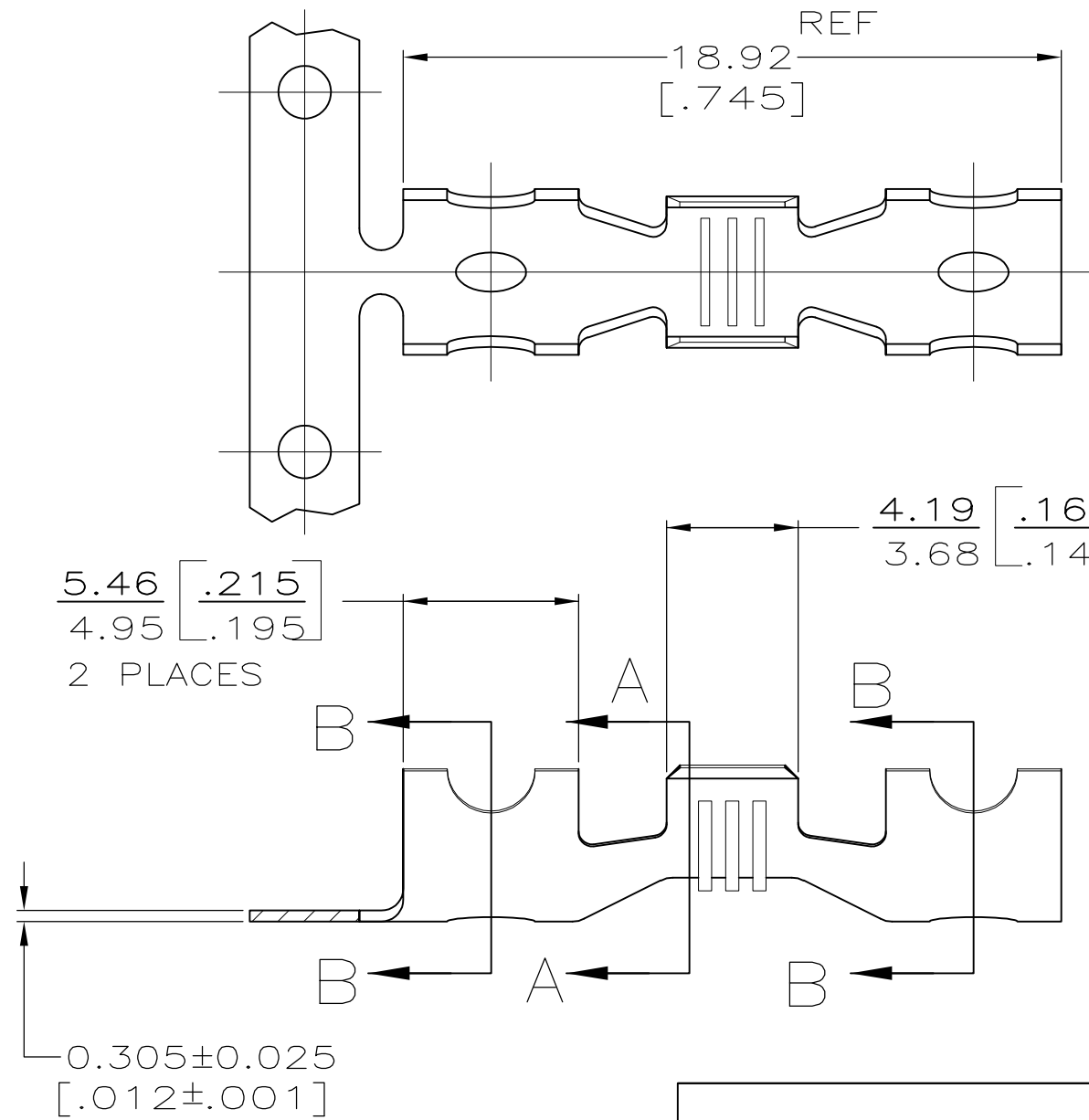

OBSOLETE	2.67-3.68 [.105-.145] DIA	1600-4100 CMA	NONE	#4 HARD BRASS	62516-2
			2	#3 HARD STEEL	62516-1
	INSULATION RANGE	WIRE RANGE	FINISH	MATERIAL	PART NUMBER

THIS DRAWING IS A CONTROLLED DOCUMENT.		DWN MICHAEL S. FEHER 9/18/89	TE Connectivity Ltd.		
DIMENSIONS: INCHES		CHK JEFF R. RUTH 9/20/89			
TOLERANCES UNLESS OTHERWISE SPECIFIED:		APVD DENNIS SCHWENK 9/20/89	NAME SPLICE		
0 PLC ± - 1 PLC ± - 2 PLC ± - 3 PLC ± 0.025 [.010] 4 PLC ± - ANGLES ± - FINISH SEE TABLE		PRODUCT SPEC TERRY L. SHUTTER 9/20/89	RESTRICTED TO		
MATERIAL SEE TABLE		APPLICATION SPEC	SIZE A3	CAGE CODE 00779	DRAWING NO C-62516
		WEIGHT 0.000000	SCALE 5:1		
		CUSTOMER DRAWING		SHEET 1 OF 1	REV C1