

THIS DRAWING IS UNPUBLISHED. RELEASED FOR PUBLICATION  
 © COPYRIGHT - By - ALL RIGHTS RESERVED.

LOC	DIST	REVISIONS					
AF	50	P	LTR	DESCRIPTION	DATE	DWN	APVD
		D		REVISED PER ECR-12-013518	24NOV12	KH	PD

1 CONTINUOUS STRIP ON REELS

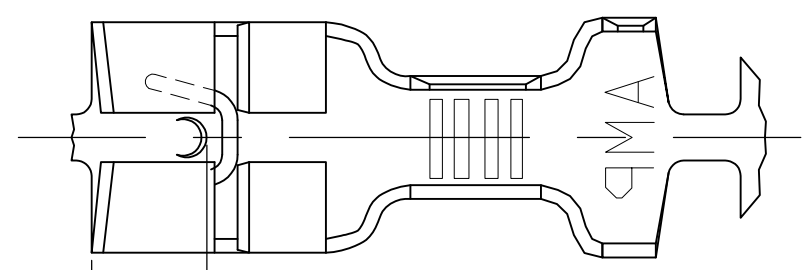

3.81  
[.150]

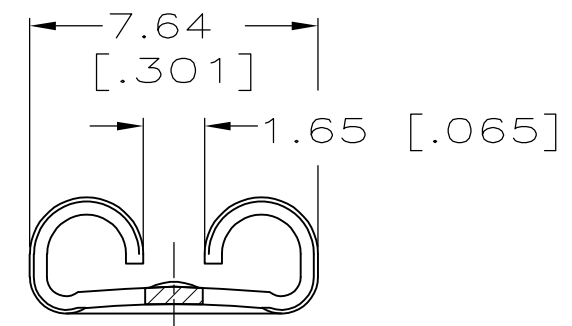

VIEW A-A  
SCALE 5:1

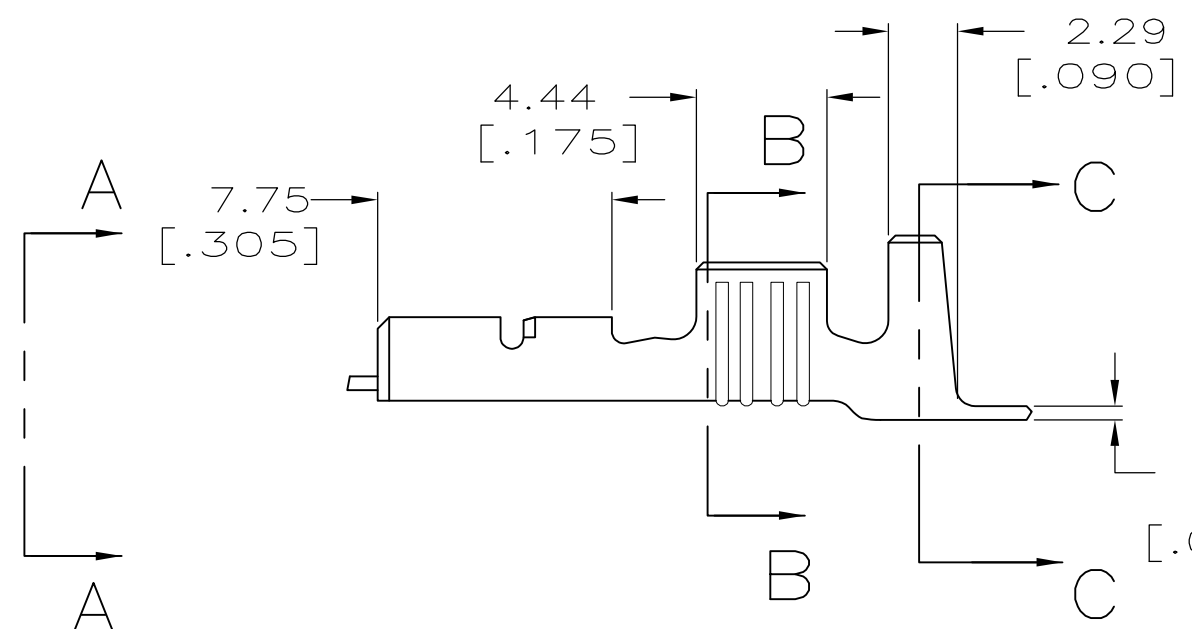

4.57 [.180]  
3.94 [.155]

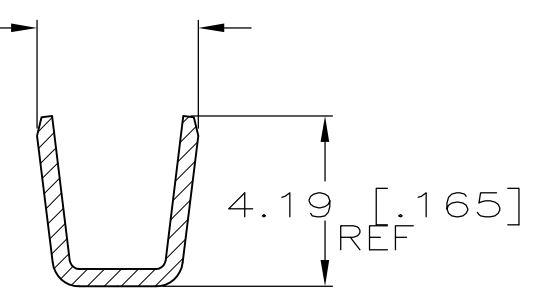

SECTION B-B  
SCALE 5:1

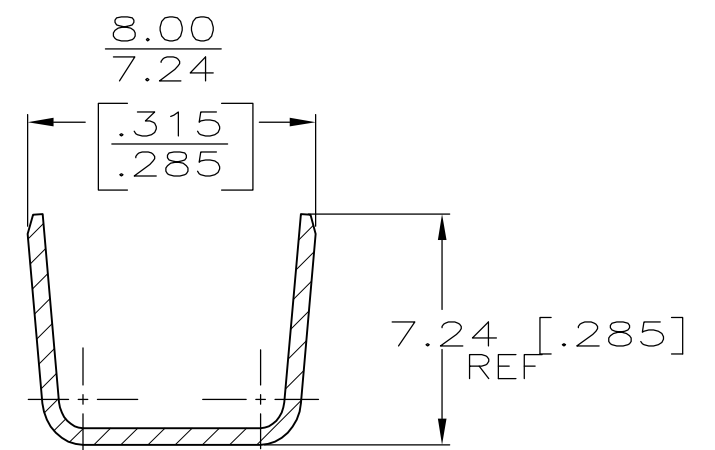

SECTION C-C  
SCALE 5:1

5.33-6.73 OR TWO 3.05 MAX [.210-.265 OR TWO .120 MAX]	1.3-3mm <sup>2</sup> OR TWO 0.8mm <sup>2</sup> [16-12 OR TWO #18]	0.81 [.032]	63800-1
INSUL RANGE	WIRE SIZE	MATING TAB THK ±0.025 [.001]	PART NO

THIS DRAWING IS A CONTROLLED DOCUMENT.		DWN JR RUTH 8/24/94	 TE Connectivity  RECPT, FASTON, LOW-INSERTION, .250 SERIES											
DIMENSIONS: mm [INCHES]		CHK MS FEHER 8/24/94												
TOLERANCES UNLESS OTHERWISE SPECIFIED:		APVD P DESANTIS 8/24/94												
<table border="0"> <tr><td>0 PLC</td><td>± -</td></tr> <tr><td>1 PLC</td><td>± -</td></tr> <tr><td>2 PLC</td><td>± 0.25 [.010]</td></tr> <tr><td>3 PLC</td><td>± -</td></tr> <tr><td>4 PLC</td><td>± -</td></tr> <tr><td>ANGLES</td><td>± -</td></tr> </table>		0 PLC			± -	1 PLC	± -	2 PLC	± 0.25 [.010]	3 PLC	± -	4 PLC	± -	ANGLES
0 PLC	± -													
1 PLC	± -													
2 PLC	± 0.25 [.010]													
3 PLC	± -													
4 PLC	± -													
ANGLES	± -													
MATERIAL BRASS	FINISH TIN	PRODUCT SPEC -	APPLICATION SPEC 114-2036	SIZE A3	CAGE CODE 00779	DRAWING NO C-63800	RESTRICTED TO -							
CUSTOMER DRAWING				SCALE 4:1	SHEET 1 OF 1	REV D								