

THIS DRAWING IS UNPUBLISHED. RELEASED FOR PUBLICATION
 © 2016 COMMScope, INC. CONFIDENTIAL NOTICE: THESE DRAWINGS AND SPECIFICATIONS ARE THE PROPRIETARY PROPERTY OF COMMScope, INC. AND MAY BE USED ONLY FOR THE SPECIFIC PURPOSE AUTHORIZED IN WRITING BY COMMScope, INC.

LOC	DIST	REVISIONS			
P	LTR	DESCRIPTION	DATE	DWN	APVD
HG	-	A	REL ACTIVE STATUS	19JUN2006	DHR DHR
		B	REVISE PER ECR-08-025002	08OCT2008	BB SG
		BI	REV PER ECR-10-015963	10AUG2010	IL CT
		C	ECN 8000019536 - REBRANDING	26JAN2017	ARL JUM

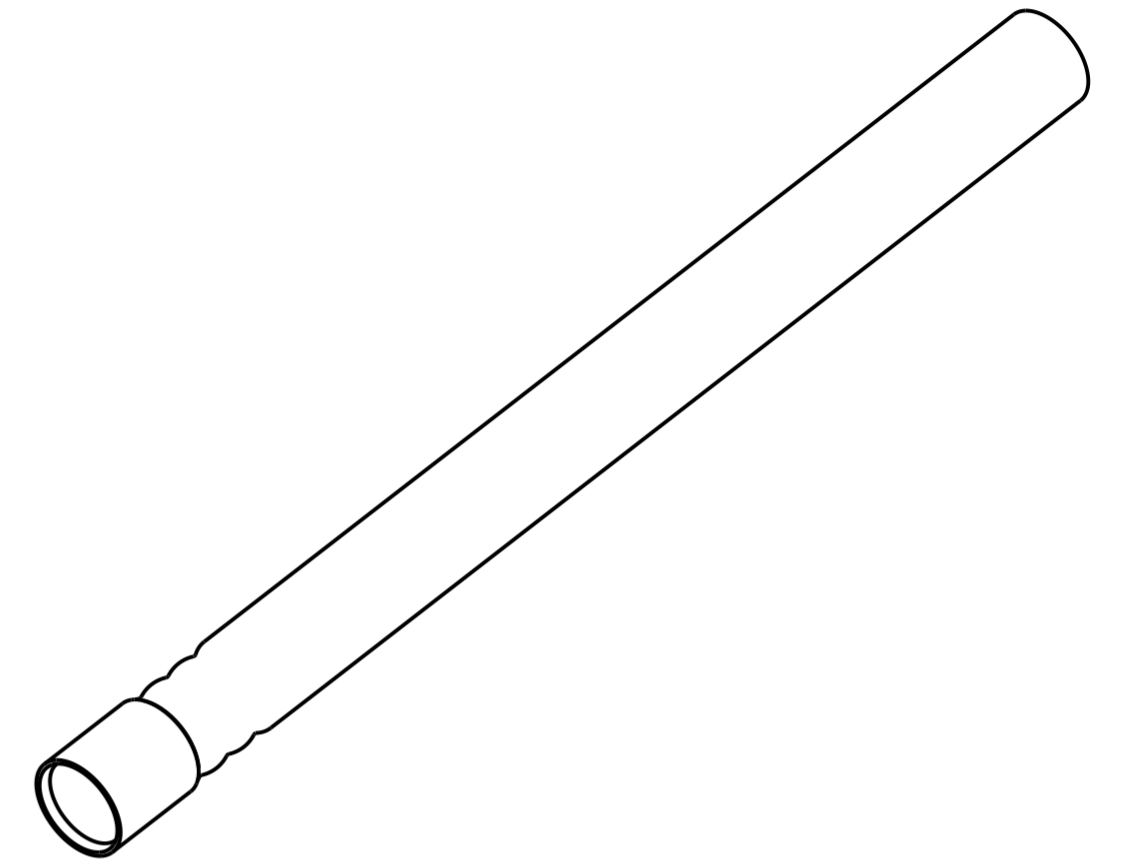
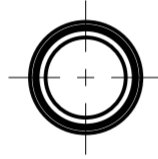

- 1. MATERIAL: CRIMP EYELET: ALUMINUM ALLOY, HEAT SHRINK: POLYOLEFIN, SEE TABLE FOR COLORS.
- 2. TUBING TO MEET UL VW-1 FLAMMABILITY REQUIREMENT.
- 3. BULK PACKAGED.
- 4. ACCOMODATES MAXIMUM CABLE OUTSIDE DIAMETER OF 2.65mm.

BLACK	26±1.5mm	6588189-4
	18±1.5mm	6588189-3
	64±1.5mm	6588189-2
	49±1.5mm	6588189-1
COLOR	L	PART NO

THIS DRAWING IS A CONTROLLED DOCUMENT.		DWN E. HOPKINS 02JUN2005	COMMScope, INC.		
DIMENSIONS: mm		CHK D. ROHDE 02JUN2005			
TOLERANCES UNLESS OTHERWISE SPECIFIED:		APVD S. BUCHTER 02JUN2005	NAME CRIMP EYELET/ HEAT SHRINK ASSY, LC CONNECTOR, 2.4/2.5mm		
0 PLC ± 1 PLC ± 2 PLC ± 3 PLC ± 4 PLC ± ANGLES ± FINISH		PRODUCT SPEC - APPLICATION SPEC - WEIGHT -	SIZE A2	CAGE CODE -	DRAWING NO G-6588189
MATERIAL -		CUSTOMER DRAWING		RESTRICTED TO -	
			SCALE 4:1	SHEET 1	OF 1
			REV C		