

SPECIFICATION CONTROL DRAWING

CONTACTS, ELECTRICAL CONNECTOR, SOCKET,
SOLDERTACTS[®], REMOVABLE, SHIELDED, SIZE 16, M39029/77 TYPE
(FOR MIL-C-38999 SERIES I, III AND IV CONNECTORS)

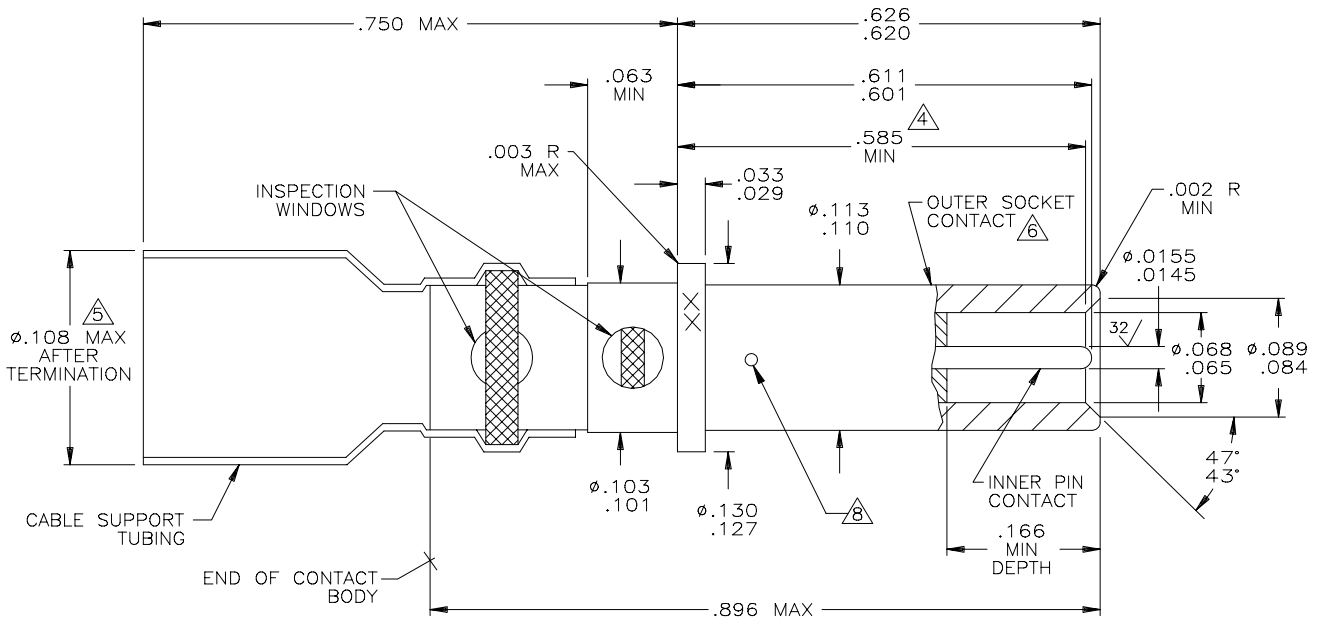

FIGURE 1.

NOTES:

1. DIMENSIONS ARE IN INCHES.
2. METRIC EQUIVALENTS CAN BE CALCULATED BASED UPON 1.00 INCH=25.4mm.
3. DIMENSIONS SHOWN APPLY AFTER PLATING.
4. POINT AT WHICH A SQUARE ENDED PIN OF THE SAME BASIC DIAMETER AS THE MATING CONTACT FIRST ENGAGES THE OUTER CONTACT SPRING. PROVISION FOR CLEARANCE HOLE SHALL BE PROVIDED.
5. SLEEVE RECOVERY: THE DIAMETER OF THE SHRINK TUBING OVER THE CABLE SHALL NOT EXCEED THE DIAMETER SHOWN.
6. MATES WITH .0635/.0615 DIA PIN
7. CONTACT WEIGHT: 0.687 GRAMS MAXIMUM UNTERMINATED.
8. THE FEATURES SHOWN ARE TWO HOLES REQUIRED TO ACCOMMODATE THE CONTACT MANUFACTURING PROCESS (REF).

NOTICE: THE INFORMATION GIVEN HEREIN IS BELIEVED TO BE RELIABLE, HOWEVER, RAYCHEM MAKES NO WARRANTIES AS TO ITS ACCURACY OR COMPLETENESS AND DISCLAIMS ANY LIABILITY IN CONNECTION WITH ITS USE. RAYCHEM'S OBLIGATIONS SHALL BE ONLY AS SET FORTH IN RAYCHEM'S STANDARD TERMS AND CONDITIONS OF SALE FOR THIS PRODUCT AND IN NO CASE WILL RAYCHEM BE LIABLE FOR ANY INCIDENTAL, INDIRECT OR CONSEQUENTIAL DAMAGES ARISING OUT OF THE SALE, RESALE, USE OR MISUSE OF THE PRODUCT.

USERS OF RAYCHEM PRODUCTS SHOULD MAKE THEIR OWN EVALUATION TO DETERMINE THE SUITABILITY OF EACH SUCH PRODUCT FOR THE SPECIFIC APPLICATION.

UNLESS OTHERWISE SPECIFIED DIMENSIONS ARE IN INCHES. METRIC DIMENSIONS ARE IN BRACKETS.

DECIMALS
.XXX ± [mm]
.XX ± [mm]
ANGLES ±

PREPARED BY: <i>TJ</i>	CAD NAME: <i>T17891a.DWG</i>	CHECKED: <i>ZT</i>	APPROVED: <i>CP</i> DEV MGR.	DOCUMENT NUMBER: D-602-0141
DATE: <small>If this document is printed it becomes uncontrolled. Check for the latest revision.</small>	DATE:	DATE:	DATE:	SHEET 1 of 6

SPECIFICATION CONTROL DRAWING

REQUIREMENTS:

DIMENSIONS (FIGURE 1), DESIGN CHARACTERISTICS, AND CONFIGURATIONS MEET THE REQUIREMENTS OF M39029/77 EXCEPT THAT THE TEMPERATURE RATING IS 125°C INSTED OF 200°C. TERMINATION IS BY SOLDERING INSTED OF CRIMPING. SEE TABLE I FOR CABLE ACCOMODATIONS.

THIS CONTACT IS QUALIFIED TO RAYCHEM SPECIFICATION D-6002.

MATING CONTACT: D-602-0140 (M39029/76)

TOOLS: SEE TABLE II.

TABLE I. DESIGN CHARACTERISTICS

CABLE ACCOMODATED <u>1/</u>	CONTACT CAVITY SIZE	TYPE	CLASS
M17/093 – RG 178 <u>2/</u> M17/094 – RG 179 M17/113 – RG 316 RAYCHEM 5026A1X*X RAYCHEM 5026D1X*X RAYCHEM 5028A1X*X RAYCHEM 5030A1X*X RAYCHEM 7528A1X*X RAYCHEM 7530A1X*X	16	D	A

1/ OTHER APPLICATIONS USING DIFFERENT CABLES MAY BE ACCOMODATED. CONSULT CONTACT MANUFACTURER FOR DETAILS.

2/ ADDITIONAL DIELECTRIC BARRIER IS REQUIRED. (RAYCHEM P/N D-600-0018 OR EQUIVALENT).

* DESIGNATION CAN BE REPLACED WITH NUMBER 1 OR 2.

TABLE II. TOOLS

HEATING TOOLS <u>3/</u>	REFLECTORS <u>3/</u>	STANDARD FIXTURE <u>3/</u>		REPAIR FIXTURE <u>3/</u>	INTALLING TOOLS	REMOVAL TOOLS
		BASIC FIXTURE	ADAPTER			
AA-400 SUPER HEATER	#979663 MINI SOLDER SLEEVE	AD-1319 OR AD1567	AT-1319-78	AD-1565	M81969/8-07 OR M81969/14-03	M81969/8-08 OR M81969/14-03
CV-5300 MINI GUN	MG-1 SOLDERSLEEVE					

3/ SEE TERMINATION PROCEDURE: RAYCHEM ES-61226

DOCUMENT NUMBER:

D-602-0141

If this document is printed it becomes uncontrolled.
Check for the latest revision.

SPECIFICATION CONTROL DRAWING

ASSEMBLY INSTRUCTIONS

1. STRIP CABLE AS SHOWN ON FIGURE 2.
2. INSERT CABLE INTO CONTACT UNTIL IT IS FULLY SEATED.
3. HEAT CONTACT WITH APPROPRIATE TOOLS AS SHOWN ON TABLE II UNTIL SOLDER MELTS AND FLOWS AND STRAIN RELIEF TUBING CONFORMS TO CABLE.
4. SEE TABLES I FOR CABLE ACCOMMODATION.

PREPARATION OF COAXIAL CABLE 30 AWG AND LARGER CENTER CONDUCTOR

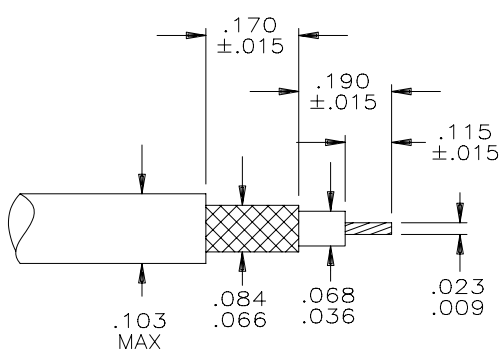

CABLE PREPARATION FOR
STRAIGHT SHIELD

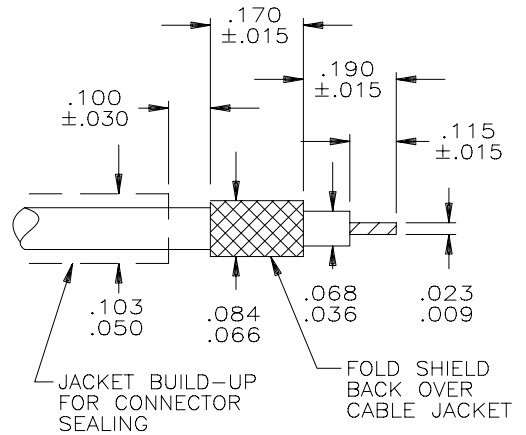

CABLE PREPARATION FOR
FOLDBACK SHIELD

PREPARATION OF COAXIAL CABLE 32 AWG AND SMALLER CENTER CONDUCTOR

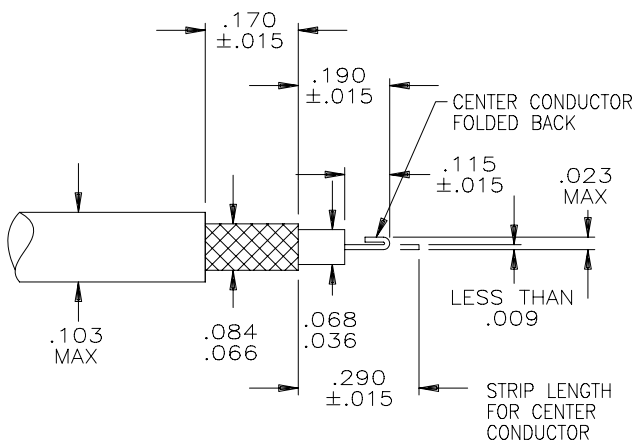

CABLE PREPARATION FOR
STRAIGHT SHIELD
FOLDBACK CENTER CONDUCTOR

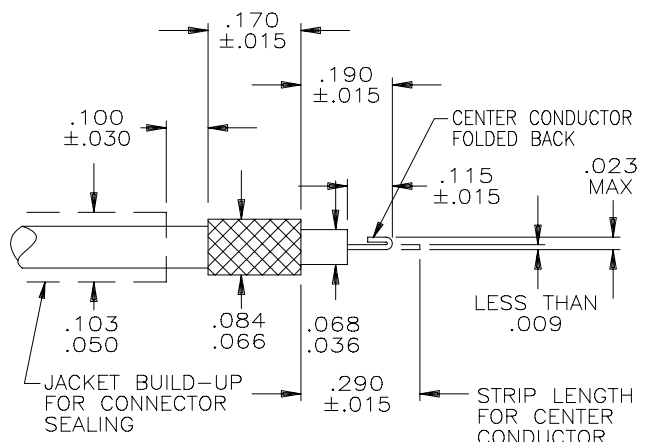

CABLE PREPARATION FOR
FOLDBACK SHIELD
FOLDBACK CENTER CONDUCTOR

FIGURE 2.

If this document is printed it becomes uncontrolled.
Check for the latest revision.

DOCUMENT NUMBER:

D-602-0141

CAD NAME: T17891c.DWG

SHEET 3 of 6

SPECIFICATION CONTROL DRAWING

PREPARATION OF COAXIAL CABLE: RG-178B/U COAXIAL CABLE

1. STRIP THE RG-178B/U COAXIAL CABLE AS SHOWN.
2. SLIP THE D-600-0018 DIELECTRIC BARRIER BETWEEN THE SHIELD BRAID AND THE CABLE DIELECTRIC (FIGURE 3.)

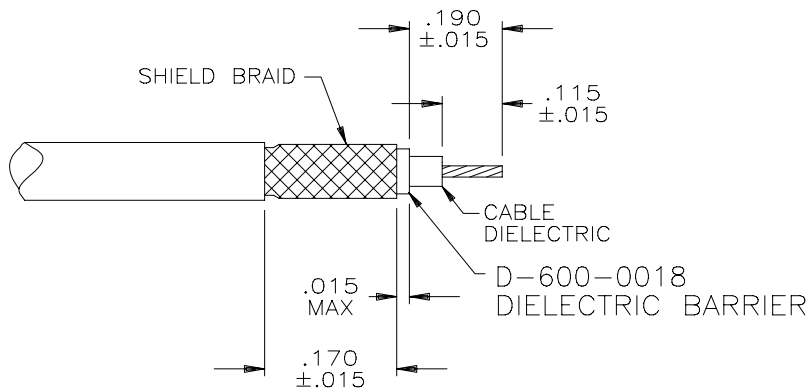

FIGURE 3.

SPECIFICATION CONTROL DRAWING

CONTACT ENGAGEMENT AND SEPARATION FORCES (OUTER SOCKET CONTACT ONLY): THE ENGAGEMENT DEPTH SHALL BE AS ENCOUNTERED IN NORMAL SERVICE. THE TEST PINS SHALL BE IN ACCORDANCE WITH MS3197 EXCEPT THE DIAMETERS SHALL BE AS SPECIFIED IN THE FOLLOWING, AND SURFACE ROUGHNESS SHALL NOT EXCEED 3 MICROINCHES. PROVISIONS FOR CLEARANCE HOLE SHALL BE PROVIDED.

TABLE III

TEST PIN DIAMETER (INCH)	MINIMUM SEPARATION FORCE (OUNCES)		MAXIMUM ENGAGEMENT FORCE (OUNCES)	
	INITIAL	AFTER CONDITIONING	INITIAL	AFTER CONDITIONING
.0635 $\begin{matrix} +.0002 \\ -.0000 \end{matrix}$	N/A	N/A	30.0	36.0
.0615 $\begin{matrix} +.0000 \\ -.0002 \end{matrix}$	2.0	1.5	N/A	N/A

DIELECTRIC WITHSTANDING VOLTAGE (APPLIED BETWEEN INNER AND OUTER CONTACT):
TEST VOLTAGE:

AT SEA LEVEL: 800 VAC. RMS.
AT 50,000 FEET: 250 VAC. RMS.

CONTACT RESISTANCE: SEE TABLE IV.

TABLE IV. CONTACT RESISTANCE

TEST CABLE	MAXIMUM VOLTAGE DROP (MILLIVOLTS)						TEST CURRENT (AMPS)	
	$25^{\circ} \begin{matrix} +3^{\circ} \\ -0^{\circ} \end{matrix} C$		$25^{\circ} \begin{matrix} +3^{\circ} \\ -0^{\circ} \end{matrix} C$ _{4/}		$125^{\circ} \begin{matrix} +3^{\circ} \\ -0^{\circ} \end{matrix} C$			
	CONTACT		CONTACT		CONTACT		CONTACT	
	INNER	OUTER	INNER	OUTER	INNER	OUTER	INNER	OUTER
M17/093 – RG 178	120	69	144	83	180	104	1.0	7.5
M17/094 – RG 179	120	44	144	53	180	66	1.0	7.5
M17/113 – RG 316	110	47	132	57	165	71	2.0	7.5
<u>RAYCHEM</u>								
5026A1311	55	54	66	65	83	81	2.0	7.5
5026D1028 <u>5/</u>	115	54	138	65	172	81	2.0	7.5
5028A1114	65	69	78	83	98	104	1.5	7.5
5030A1114	60	110	72	132	90	165	1.0	7.5
7528A1317 <u>5/</u>	135	47	162	57	203	71	1.5	7.5
7530A1118 <u>5/</u>	120	54	144	65	180	81	1.0	7.5

4/ AFTER CONDITIONING.

If this document is printed it becomes uncontrolled.
Check for the latest revision.

5/ CENTER CONDUCTOR PLATED STEEL

DOCUMENT NUMBER:

D-602-0141

CAD NAME: T17891e.DWG

SHEET 5 of 6

SPECIFICATION CONTROL DRAWING

LOW SIGNAL LEVEL CONTACT RESISTANCE (INNER CONTACT ONLY): SEE TABLE V.

TENSILE STRENGTH (INNER AND OUTER CONTACT SOLDER JOINT): SEE TABLE V.

TABLE V. LOW SIGNAL LEVEL CONTACT RESISTANCE
(INNER CONTACT ONLY) AND TENSILE STRENGTH

TEST CABLE	MAXIMUM CONTACT RESISTANCE (MILLIOHMS)		MINIMUM TENSILE STRENGTH (POUNDS)	
	INITIAL	AFTER CONDITIONING	INNER CONTACT	OUTER CONTACT
M17/093 – RG 178	120	144	3.5	10.0
M17/094 – RG 179	120	144	3.5	15.0
M17/113 – RG 316	55	66	10.0	15.0
<u>RAYCHEM</u>				
5026A1311	33	40	6.0	15.0
5026D1028 <u>5/</u>	58	70	6.0	15.0
5028A1114	45	54	6.0	15.0
5030A1114	66	80	3.5	10.0
7528A1317 <u>5/</u>	93	112	6.0	15.0
7530A1118 <u>5/</u>	120	144	3.5	15.0

5/ CENTER CONDUCTOR PLATED STEEL.

MATERIAL:	CONTACT BODY	BERYLLIUM COPPER, ALLOY 173, CONDITION H PER ASTM B196
	INNER CONTACT	BERYLLIUM COPPER, ALLOY 173, CONDITION H PER ASTM B196
	PLATING (CONTACT BODY AND INNER CONTACT)	GOLD PLATE PER MIL-G-45204 TYPE II, GRADE C 50 MICROINCHES MINIMUM OVER NICKEL PER QQ-N-290A 50 MICROINCHES MINIMUM OVER COPPER STRIKE – 40 MICROINCHES MAXIMUM
	SOLDER	Sn63 PER QQ-S-571
	FLUX	TYPE RMA PER QQ-S-571
	SHRINK TUBING	HEAT-SHRINKABLE, RADIATION-CROSSLINKED POLYVINYLIDENE FLUORIDE
	DIELECTRIC	ETFE FLUOROPOLYMER PER ASTM D3159

SHIPPING FIGURE 1 INDICATES THE ONE-PIECE ASSEMBLY. TERMINATION INSTRUCTIONS ARE TO BE SHIPPED WITH THE UNIT PACKAGE.

DOCUMENT NUMBER:

D-602-0141

If this document is printed it becomes uncontrolled.
Check for the latest revision.

CAD NAME: T17891f.DWG

SHEET 6 of 6