



## SL-630 SERIES

### SPECIFICATIONS

- ◆ **High/low liquid level monitor**
- ◆ **“Peel and stick” to the outside of a wide range of plastic containers**
- ◆ **Never comes in contact with liquid – no risk of contamination or volume displacement**
- ◆ **Proven ultrasonic technology**
- ◆ **Repeatability:  $\pm 0.1$ ” (2.54 mm)**

The Non-Invasive Sonic Eye™ SL-630 is a cost effective ultrasonic sensor for plastic containers. The sensor is designed to adhere to the outside of plastic containers with diameters from 2” (50.8mm) to 10” (254mm) with a wall thickness up to 0.25” (6.35mm) as a high/low level liquid level monitor. The sensor sticks to the outside of the container, never coming in contact with the liquid, so there is no contamination or volume displacement.

### FEATURES

- ◆ No calibration required
- ◆ Non-invasive miniature sensor designed to stick to outside of container
- ◆ Integral electronics with disposable mounting
- ◆ Effective on plastic bottles with diameters ranging from 2” (50.8 mm) to 10” (254 mm)
- ◆ Independent of color, transparency, shape and size of bottom of container
- ◆ No displacement of liquid volume
- ◆ Eliminates fluid contamination problem

### APPLICATIONS

- ◆ Chemical Analyzer
- ◆ Immuno Chemistry
- ◆ Chromatography
- ◆ Kidney Dialysis
- ◆ Clinical Chemistry
- ◆ Medical Laser System
- ◆ Hemodialysis
- ◆ Semiconductor
- ◆ Waste Management

**PERFORMANCE SPECIFICATIONS**

Parameter	Typical Value
Repeatability	± 0.1" (2.54 mm)
Response Time	200 milliseconds
Input Power	5 to 24 VDC
Leakage Current	Less than 50 µA
Output	TTL (high) – dry condition
Mounting	Reusable sensor/disposable mounting tape

Parameter	Typical Value
Protection	Transient, reverse polarity
Effective Plastic Bottle Diameter	2" (50.8 mm) to 10" (254 mm)
Wall Thickness	Up to 0.25" (6.35 mm)
Sensor Material	ULTEM® (plastic)
Temperature	-20 to 158 °F (30 to 70 °C)
Cable Length	12" (305 mm) (for longer lengths consult factory)

**MECHANICAL DIMENSIONS IN INCHES**

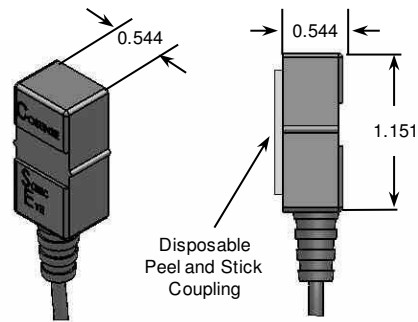

Figure 1: SL-630 series element with peel and stick disposable mounting tape.

NOTES: Clean area on container before installing. Remove backing from tape and adhere to container. Press sensor to container firmly

**WIRING DIAGRAM**

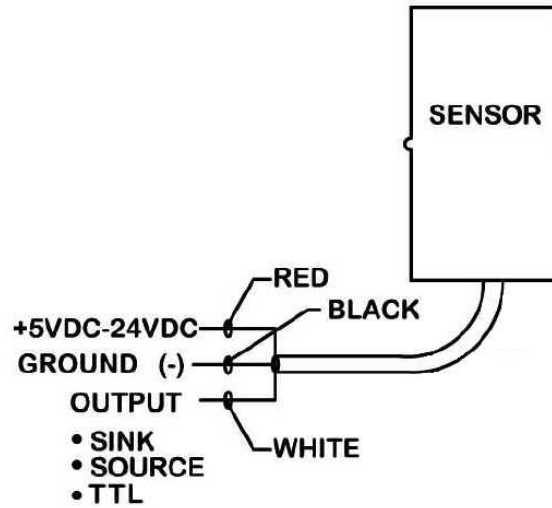

Figure 3: Wiring diagram for SL-630 series elements.

**ORDERING INFORMATION**

Input	Output	Part Number
5 – 24 VDC	TTL	SL-630-C01

**NORTH AMERICA**

Measurement Specialties, Inc.,  
 a TE Connectivity Company  
 Phone +1-800-522-6752  
 Email: [customercare.hmpt@te.com](mailto:customercare.hmpt@te.com)

**EUROPE**

MEAS Deutschland GmbH(Europe)  
 a TE Connectivity Company  
 Phone: +49-800-440-5100  
 Email: [customercare.tlse@te.com](mailto:customercare.tlse@te.com)

**ASIA**

Measurement Specialties (China), Ltd.,  
 a TE Connectivity Company  
 Phone: +86-400-820-6015  
 Email: [customercare.shzn@te.com](mailto:customercare.shzn@te.com)

**TE.com/sensorsolutions**

Measurement Specialties, Inc., a TE Connectivity company.

Accustar, American Sensor Technologies, AST, ATEXIS, DEUTSCH, IdentiCal, TruBlue, KPSI, Krystal Bond, Microfused, UltraStable, Measurement Specialties, MEAS, Schaevitz, TE Connectivity, TE, and the TE connectivity (logo) are trademarks of the TE Connectivity Ltd. family of companies. Other logos, product and company names mentioned herein may be trademarks of their respective owners.

The information given herein, including drawings, illustrations and schematics which are intended for illustration purposes only, is believed to be reliable. However, TE Connectivity makes no warranties as to its accuracy or completeness and disclaims any liability in connection with its use. TE Connectivity's obligations shall only be as set forth in TE Connectivity's Standard Terms and Conditions of Sale for this product and in no case will TE Connectivity be liable for any incidental, indirect or consequential damages arising out of the sale, resale, use or misuse of the product. Users of TE Connectivity products should make their own evaluation to determine the suitability of each such product for the specific application.