

Vertical Cavity Surface Emitting Laser in Lateral Package

OPV380

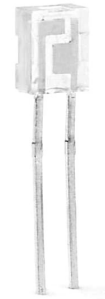

Features:

- 850 nm VCSEL technology
- High thermal stability
- Low drive current
- High output power
- Narrow beam angle

Description:

The OPV380 is a Vertical Cavity Surface Emitting Laser (VCSEL) packaged in a flat lens lateral package. VCSELs offer many advantages in sensing applications when compared to infrared LEDs. These devices require substantially lower drive currents to obtain the same amount of output power as LEDs. This feature allows VCSELs to be used in low power consumption applications such as battery operated equipment.

The flat lens packaging allows the device to be used with secondary optics to create custom beam profiles. The OPV380 is optically and spectrally compatible with Optek's standard detector products such as the OP550 series phototransistors, OP530 series photodarlington and the OP900 series photodiodes.

Applications:

- Non-contact position sensing
- Photoelectric sensors
- Optical encoders
- Light curtains

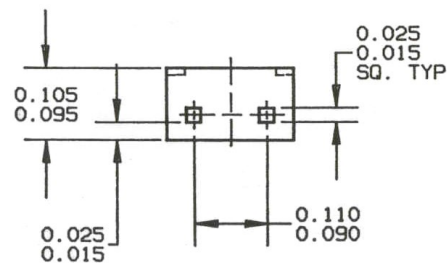
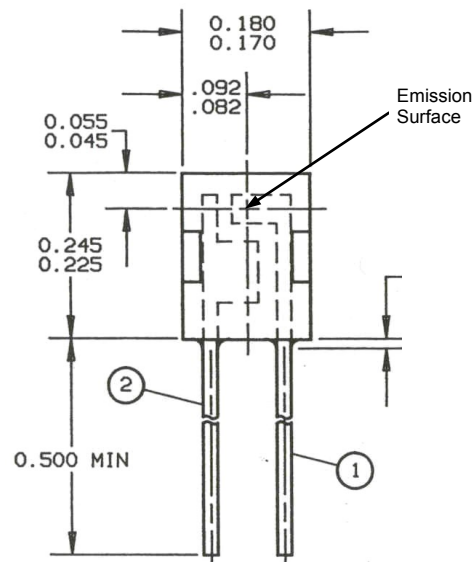

RoHS

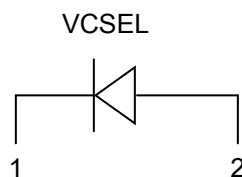

Additional laser safety information can be found on the Optek website. See application bulletin #221.

Classification is not marked on the device due to space limitations. See package outline for centerline of optical radiance. Operating devices beyond maximum rating may result in hazardous radiation exposure.

General Note

TT Electronics reserves the right to make changes in product specification without notice or liability. All information is subject to TT Electronics' own data and is considered accurate at time of going to print.

Vertical Cavity Surface Emitting Laser in Lateral Package

OPV380



Electrical Specifications

Absolute Maximum Ratings ($T_A = 25^\circ\text{C}$ unless otherwise noted)	
Storage Temperature Range	-40° to +100° C
Operating Temperature Range	0° to +85° C
Lead Soldering Temperature [1/16 inch (1.6mm) from case for 5 sec with soldering iron]	260° C ⁽¹⁾
Maximum Forward Peak Current, Continuous	12 mA
Maximum Reverse Voltage	5 V
Maximum Forward Current, pulsed (1 μ s P.W., 10% D.C.)	48 mA

Electrical Characteristics ($T_A = 25^\circ\text{C}$ unless otherwise noted)						
SYMBOL	PARAMETER	MIN	TYP	MAX	UNITS	TEST CONDITIONS
P_{OT}	Total Power Out	1.5			mW	$I_F = 7\text{ mA}$
I_{TH}	Threshold Current			3.0	mA	Note 2
V_F	Forward Voltage			2.2	V	$I_F = 7\text{ mA}$
I_R	Reverse Current			100	nA	$V_R = 5\text{ V}$
R_S	Series Resistance	20		55	ohms	Note 3
η	Slope Efficiency	0.28			mW/mA	Note 4
λ	Wavelength	840		860	nm	
$\Delta\lambda$	Optical Bandwidth			0.85	nm	
θ	Beam Divergence		20		Degrees	FWHM
$\Delta\eta/\Delta T$	Temp Coefficient of Slope Efficiency		-0.50		%/°C	(0° - 70°C), Note 4
$\Delta\lambda/\Delta T$	Temp Coefficient of Wavelength		0.06		nm/°C	(0° - 70°C)
ΔI_{TH}	Temp Variance of Threshold Current		± 1.0		mA	(0° - 70°C), Note 2
$\Delta V_F/\Delta T$	Temp Coefficient for Forward Voltage		-2.5		mV/°C	(0° - 70°C)

NOTES:

- (1) RMA flux is recommended. Solder dwell time can be increased to 10 seconds when flow soldering.
- (2) Threshold Current is based on the two line intersection method specified in Telcordia GR-468-Core. Line 1 from 4 mA to 6 mA. Line 2 from 0 mA to 0.5 mA.
- (3) Series Resistance is the slope of the Voltage-Current line from 5 to 8 mA.
- (4) Slope efficiency, is the slope of the best fit LI line from 5 mA to 8 mA with 0.25mA test intervals.

General Note

TT Electronics reserves the right to make changes in product specification without notice or liability. All information is subject to TT Electronics' own data and is considered accurate at time of going to print.

TT Electronics | Optek Technology, Inc.
 1645 Wallace Drive, Ste. 130, Carrollton, TX USA 75006 | Ph: +1 972 323 2200
www.ttelectronics.com | sensors@ttelectronics.com

Vertical Cavity Surface Emitting Laser in Lateral Package

OPV380

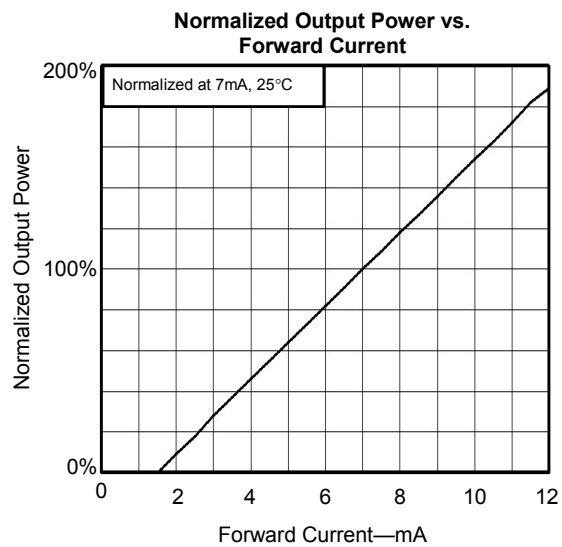
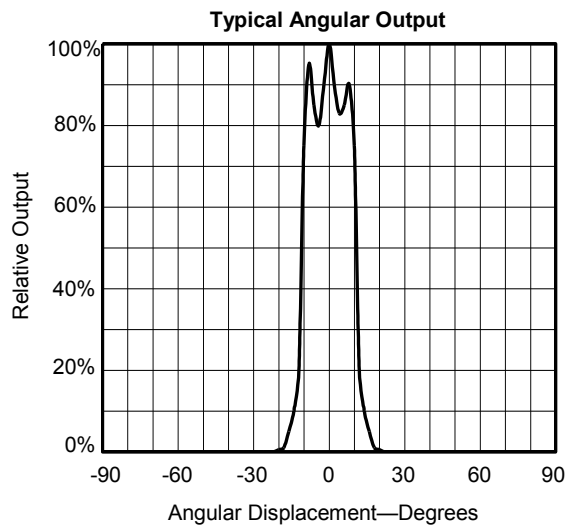

General Note
TT Electronics reserves the right to make changes in product specification without notice or liability. All information is subject to TT Electronics' own data and is considered accurate at time of going to print.

TT Electronics | Optek Technology, Inc.
1645 Wallace Drive, Ste. 130, Carrollton, TX USA 75006 | Ph: +1 972 323 2200
www.ttelectronics.com | sensors@ttelectronics.com

Vertical Cavity Surface Emitting Laser in Lateral Package

OPV380



Issue	Change Description	Approval	Date
1.0	Initial Release (Preliminary)	G. Cawley	3/30/05
1.1	Final Release	G. Cawley	5/25/05
1.2	Update Absolute Maximum Ratings chart and Electrical Characteristics.	Harry Whitford	9/11/09

General Note
TT Electronics reserves the right to make changes in product specification without notice or liability. All information is subject to TT Electronics' own data and is considered accurate at time of going to print.