

# Integrated Pressure Transducer IPT

Honeywell's Integrated Pressure Transducer (IPT) provides high accuracy pressure data in an industry standard SPI digital format. The core of the IPT is a proven Honeywell silicon piezoresistive pressure sensor with both pressure and temperature sensitive elements. The IPT is small and lightweight and can be easily integrated by the user into a wide variety of applications that require high performance in a small package. Applying the coefficients stored in the on-board EEPROM to the normalized IPT pressure and temperature output yields highly accurate and stable pressure readings over the -40 to 85°C compensated temperature range.

## APPLICATIONS:

- Air Data Computers
- Altimeters
- Cabin Air Pressure
- Engine Test Systems
- Flight Test Systems
- Meteorology
- Flow and Pressure Calibrators
- Instrumentation and Analytical Equipment
- Research and Development

0.04% FS Total Error Band, -40 to 85°C, Absolute

Small and Lightweight

Excellent Pressure Stability

±0.10% FS Total Error Band, -40 to 85°C, Gauge/Differential

ISO-9001  
ISO-14001

## FEATURES AND BENEFITS

- ▶ **High Accuracy Over a Wide Temperature Range**  
From -40 to 85°C  
±0.04% FS Total Error Band (absolute pressure),  
to ±0.10% FS Total Error Band (gauge/ differential pressure) <sup>(1)</sup>
- ▶ **Stored Correction Coefficients in EEPROM** – Ready to use; No additional pressure and temperature calibration necessary.  
**Simplifies System Design** – No additional signal compensation needed to achieve a highly accurate pressure reading.
- ▶ **Digital SPI Output**
- ▶ **Industry Standard Interface** – Ready communication between a  $\mu$ Controller/ $\mu$ Processor and the IPT.
- ▶ **Small and Versatile**
- ▶ **Volume** ~ 1 in<sup>3</sup> (16 cm<sup>3</sup>)  
**Lightweight** – Less than 10 grams.  
**Media Interface** – Handles most dry gas media.

# IPT

## DIMENSIONS

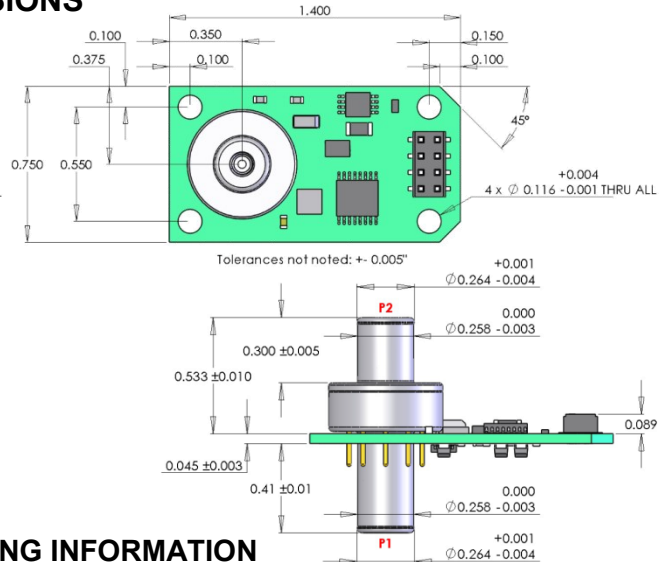
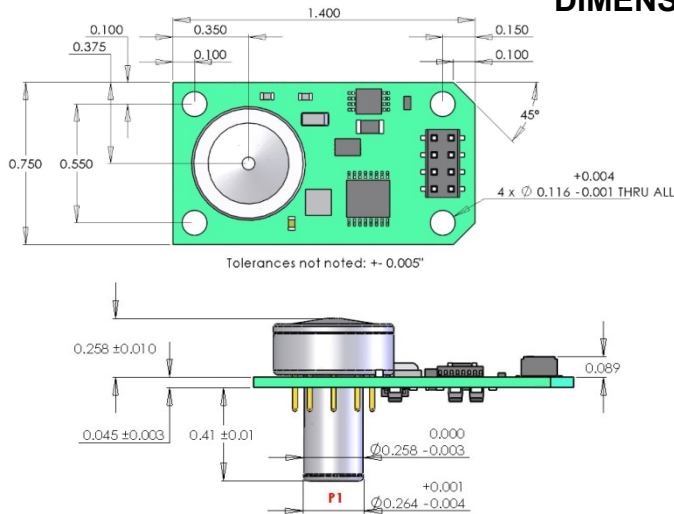

## SPECIFICATIONS

### Performance Specifications <sup>(1)</sup>

**Total Error:** (from -40 to 85°C)  
 ±0.04%FS absolute  
 ±0.10%FS gauge, differential  
 ±0.20%FS 1 psi gauge  
**Temperature Range:**  
 Operating -40 to 85°C (-40 to 185°F)  
 Storage: -55 to 125°C (-67 to 257°F)  
**Long Term Stability:**  
 0.025% FS max per year typical

### Mechanical Specifications

**Pressure Ranges and Type:**  
 See Ordering Information at right  
**Pressure Units:** PSI<sup>(2)</sup>  
**Media Compatibility:** Suitable for non-condensing, non-corrosive, and non-combustible gases.  
**Weight<sup>(3)</sup>:** ≈ 8.0 grams (absolute)  
 ≈ 9.7 grams (gauge, differential)

### Electrical Specifications

**Output:**  
 24-bit pressure value  
 16-bit temperature value  
 256 x 8 EEPROM configuration  
**Power Requirements:**  
 Supply Voltage: 4 to 12 VDC  
**Current Consumption:**  
 6 mA typical, 7.5 mA max  
**Interface:** 3.3V SPI (mode 1,1) SCLK ≤5 Mhz  
**Sample Rate:** 166 samples/second

### Environmental Features <sup>(3)</sup>

**Overpressure:** 3x FS  
**Burst Pressure:** 3x FS  
**Mechanical Shock:** DO-160E Section 7.0, Category A, Figure 7.2, Operational Standard  
**Thermal Shock:** Storage Temperature Cycling per JESD22-104, Section 5.0: -55 to +125°C  
**Vibration:** DO-160E Section 8, Category H, Aircraft Type 2, Aircraft Zones 1 & 2  
**RoHS:** Compliant

## Find out more

For more information visit us online at [www.pressuresensing.com](http://www.pressuresensing.com)  
 Customer Service Email: [quotes@honeywell.com](mailto:quotes@honeywell.com)

Honeywell reserves the right to make changes to improve reliability, function or design. Honeywell does not assume any liability arising out of the application or use of any product or circuit described herein; neither does it convey any license under its patent rights nor the rights of others.

## ORDERING INFORMATION

### IPT Integrated Pressure Transducer

#### FULL SCALE PRESSURE RANGE

	Absolute	Gauge	Differential
0001	N/A	1 PSI <sup>(1)</sup>	±1 PSI
0002	N/A	2 PSI	±2 PSI
0005	N/A	5 PSI	±5 PSI
0010	N/A	10 PSI	±10 PSI
0020	20 PSI	20 PSI	±20 PSI
0050	50 PSI	50 PSI	±50 PSI

TYPE		P1 Pressure	P2 Pressure
A	Absolute	0 (vacuum) to FS	N/A
G	Gauge	Reference to FS	Reference
D	Differential	+FS to -FS rel. to P2	+FS to -FS rel. to P1

#### DIGITAL INTERFACE VOLTAGE

33 3.3 volts

#### POWER SUPPLY

R Regulated, 4-12VDC

#### OPTIONS

A Demonstration Kit <sup>(4)</sup>

IPT 0020 A 33 R A

## CONNECTOR

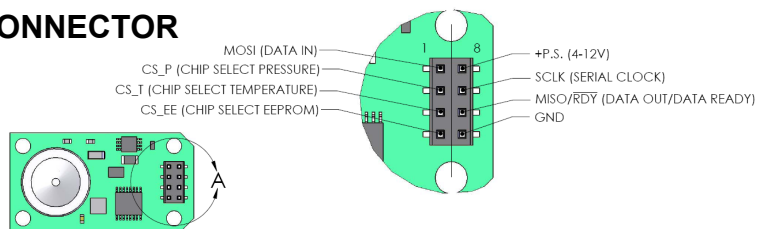

<sup>(1)</sup> Total Error is the sum of worst case linearity, repeatability, hysteresis, thermal effects, and calibration errors over the operating temperature range. Accuracy is only achieved after applying the correction coefficients and algorithm as shown in section 3.2. of Product Specification (FS = Full Scale). For total error calculations of differential units, "Full Scale" is the pressure difference between the minimum and maximum pressures. For example, full scale for a 1 psid PPT is 2 psi (-1 to +1 psi). Pressure range 1psi gauge has total error of ±0.20% FS. <sup>(2)</sup> After applying the correction coefficients stored in EEPROM, the resultant pressure reading is expressed in PSI (pounds per square inch). <sup>(3)</sup> Not including mounting hardware. <sup>(4)</sup> Demonstration kit includes RS-232 Cable, Demo Board, AC adapter, MS Windows Software, and User's Manual.

**ESD (electrostatic discharge) sensitive device.** Damage may occur when subjected to high energy ESD. Proper ESD precautions should be taken to avoid performance degradation or loss of functionality.

**EOS (electrical overstress) sensitive device.**

Damage may occur when subjected to EOS. Do not exceed specified ratings to avoid performance degradation or loss of functionality.