

# Customer Information Sheet

DRAWING No.: M20-782XXXX

SHEET 2 OF 2

IF IN DOUBT - ASK

©

NOT TO SCALE

THIRD ANGLE PROJECTION

ALL DIMENSIONS IN mm

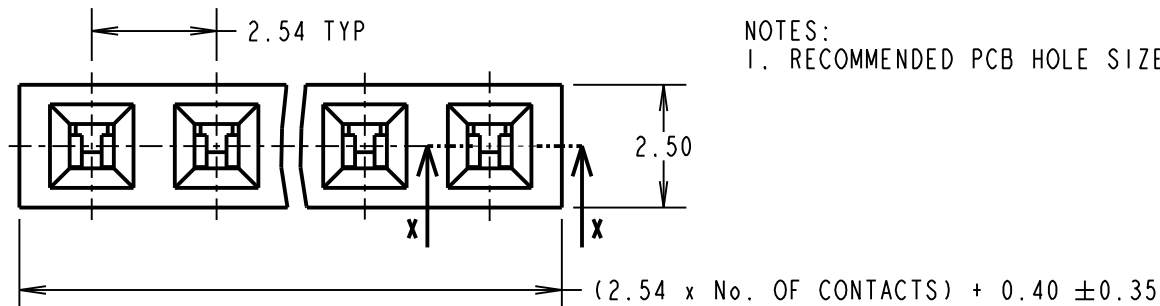

NOTES:  
1. RECOMMENDED PCB HOLE SIZE =  $\varnothing 1.00\text{mm}$ .

**SPECIFICATION:**  
**MATERIAL:**  
 MOULDING = PA9T UL94V-0, BLACK  
 CONTACTS = PHOSPHOR BRONZE  
**FINISH (OVER NICKEL):**  
 42 = GOLD FLASH ON CONTACT AREA,  
 100% TIN ON TAILS  
 46 = 100% TIN  
**ELECTRICAL:**  
 CURRENT RATING = 3A  
 VOLTAGE PROOF = 1000V AC  
 CONTACT RESISTANCE =  $20\text{m}\Omega$  MAX  
 INSULATION RESISTANCE =  $1,000\text{M}\Omega$  MIN  
**ENVIRONMENTAL:**  
 TEMPERATURE RANGE =  $-40^{\circ}\text{C}$  TO  $+105^{\circ}\text{C}$   
**MECHANICAL:**  
 INSERTION FORCE = 1.96N MAX  
 WITHDRAWAL FORCE = 0.29N MIN  
 DURABILITY = 300 OPERATIONS  
**PACKING:**  
 TUBE  
 FOR COMPLETE SPECIFICATION SEE COMPONENT SPECIFICATION C001XX (LATEST ISSUE)

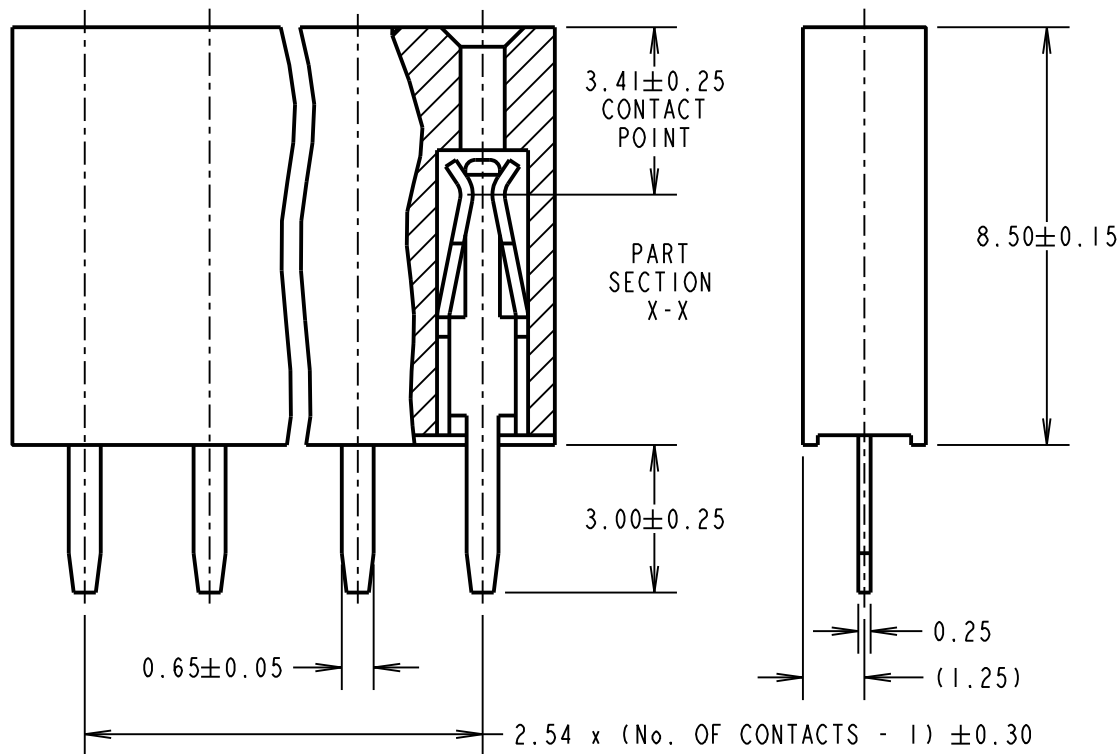

ORDER CODE:

**M20-782XXXX**

No. OF CONTACTS: \_\_\_\_\_  
02 TO 20, 25, 32, 36

FINISH: \_\_\_\_\_  
42 = SELECTIVE GOLD / 100% TIN  
46 = 100% TIN

WJP	10	01.08.17	20398
NAME	ISS.	DATE	C/NOTE
APPROVED: W. J. PRESTON			
CHECKED: M. PLESTED			
DRAWN: J. EVANS			
CUSTOMER REF.:			
ASSEMBLY DRG:			

**HARWIN**

www.harwin.com  
technical@harwin.com

THIS DRAWING AND ANY INFORMATION OR DESCRIPTIVE MATTER SET OUT HEREON ARE CONFIDENTIAL AND COPYRIGHT PROPERTY OF THE HARWIN GROUP AND MUST NOT BE DISCLOSED, LOANED, COPIED OR USED FOR MANUFACTURING, TENDERING OR FOR ANY OTHER PURPOSE WITHOUT THEIR WRITTEN PERMISSION.

**TOLERANCES**  
 X. =  $\pm 1\text{mm}$   
 X.X =  $\pm 0.50\text{mm}$   
 X.XX =  $\pm 0.10\text{mm}$   
 X.XXX =  $\pm 0.01\text{mm}$   
 ANGLES =  $\pm 5^{\circ}$   
 UNLESS STATED

**MATERIAL:**

SEE ABOVE

**FINISH:** SEE ABOVE

**S/AREA:** mm<sup>2</sup>

**TITLE:**

2.54mm PITCH SIL VERTICAL  
PC TAIL SOCKET ASSEMBLY

**DRAWING NUMBER:**

**M20-782XXXX**

SHT  
2 OF 2