

High Voltage Power Operational Amplifiers

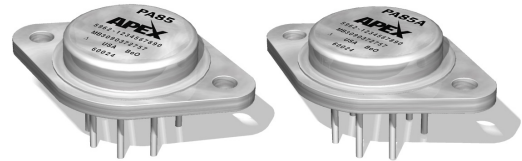

FEATURES

- High Voltage — 450V ($\pm 225V$)
- High Slew Rate — 1000V/ μs
- High Output Current — 200mA
- 500 kHz Power Bandwidth



APPLICATIONS

- High Voltage Instrumentation
- Piezo Transducer Excitation
- Programmable Power Supplies up to 430V
- Electrostatic Transducers & Deflection

DESCRIPTION

The PA85 is a high voltage, high power bandwidth MOSFET operational amplifier designed for output currents up to 200mA. Output voltages can swing up to $\pm 215V$ with a dual supply and up to +440 volts with a single supply. The safe operating area (SOA) has no second breakdown limitations and can be observed with all types of loads by choosing an appropriate current limiting resistor. High accuracy is achieved with a cascode input circuit configuration. All internal biasing is referenced to a bootstrapped zener-MOSFET current source. As a result, the PA85 features an unprecedented supply range and excellent supply rejection. The MOSFET output stage is biased on for linear operation. External compensation provides user flexibility.

This hybrid circuit utilizes thick film (cermet) resistors, ceramic capacitors and silicon semiconductor chips to maximize reliability, minimize size and give top performance. Ultrasonically bonded aluminum wires provide reliable interconnections at all operating temperatures. The 8-pin TO-3 package is hermetically sealed and electrically isolated. The use of compressible isolation washers voids the warranty.

TYPICAL CONNECTION

Figure 1: Typical Connection

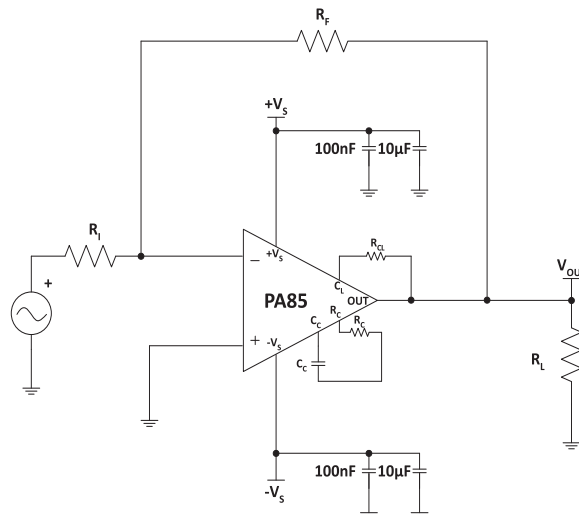

PINOUT AND DESCRIPTION TABLE

Figure 2: External Connections

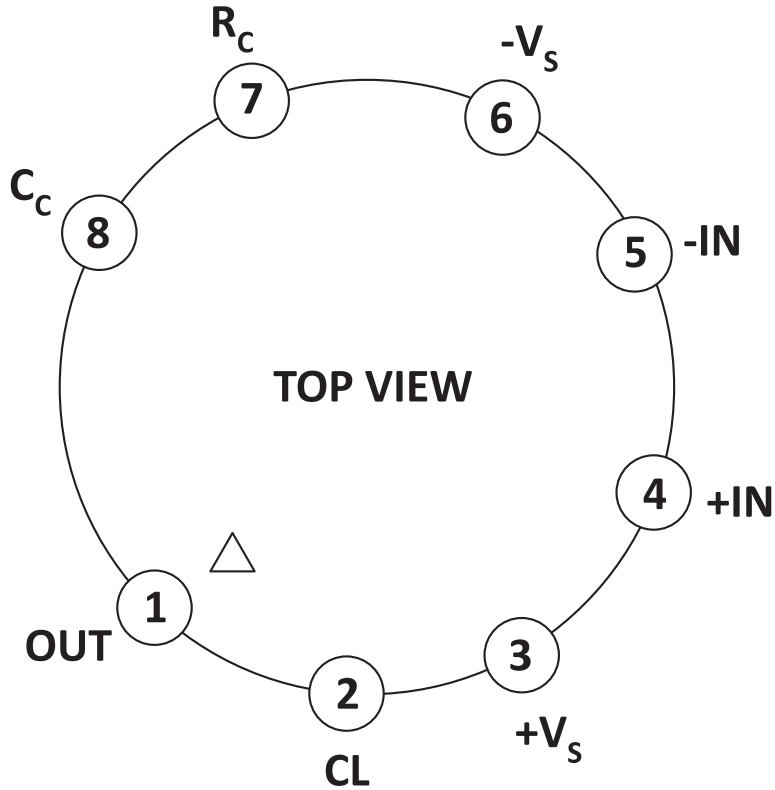

Pin Number	Name	Description
1	OUT	The output. Connect this pin to load and to the feedback resistors.
2	CL	Connect to the current limit resistor, and then the OUT pin. Output current flows into/out of this pin through R_{CL} .
3	+Vs	The positive supply rail.
4	+IN	The non-inverting input.
5	-IN	The inverting input.
6	-Vs	The negative supply rail.
7	RC	Compensation resistor connection. Select value based on Phase Compensation. See applicable section.
8	CC	Compensation capacitor connection. Select value based on Phase Compensation. See applicable section.

SPECIFICATIONS

Unless otherwise noted: $T_C = 25^\circ\text{C}$, compensation = $C_C = 68\text{pF}$, $R_C = 100\ \Omega$. DC input specifications are \pm value given. Power supply voltage is typical rating.

Absolute Maximum Ratings

Parameter	Symbol	Min	Max	Units
Supply Voltage, total	$+V_S$ to $-V_S$		450	V
Output Current, continuous within SOA	I_O		200	mA
Power Dissipation, continuous @ $T_C = 25^\circ\text{C}$	P_D		30	W
Input Voltage, differential	V_{IN} (Diff)	-25	+25	V
Input Voltage, common mode	V_{cm}	$-V_S$	$+V_S$	V
Temperature, pin solder, 10s max.			350	$^\circ\text{C}$
Temperature, junction ¹	T_J		150	$^\circ\text{C}$
Temperature Range, storage		-65	+150	$^\circ\text{C}$
Operating Temperature Range, case	T_C	-55	+125	$^\circ\text{C}$

1. Long term operation at the maximum junction temperature will result in reduced product life. Derate internal power dissipation to achieve high MTTF. Ratings apply only to output transistors. An additional 10W may be dissipated due to quiescent power.

The PA85 is constructed from MOSFET transistors. ESD handling procedures must be observed. The internal substrate contains beryllia (BeO). Do not break the seal. If accidentally broken, do not crush, machine, or subject to temperatures in excess of 850°C to avoid generating toxic fumes.

CAUTION

INPUT

Parameter	Test Conditions	PA85			PA85A			Units
		Min	Typ	Max	Min	Typ	Max	
Offset Voltage, initial			0.5	2		0.25	0.5	mV
Offset Voltage vs. temperature	Full temp range		10	30		5	10	$\mu\text{V}/^\circ\text{C}$
Offset Voltage vs. supply			3	10		*	*	$\mu\text{V}/\text{V}$
Offset Voltage vs. time			75			*		$\mu\text{V}/\sqrt{\text{kh}}$
Bias Current, initial ¹			5	50		3	10	μA
Bias Current vs. supply			0.01			*		$\mu\text{A}/\text{V}$
Offset Current, initial ¹			10	100		3	30	μA
Input Impedance, DC			10^{11}			*		Ω
Input Capacitance			4			*		pF
Common Mode Voltage Range ²		$\pm V_S - 15$			*			V
Common Mode Rejection, DC	$V_{\text{CM}} = \pm 90\text{V}$	90	110		*	*		dB
Noise	100 kHz BW, $R_S = 1\text{K}\Omega$, $C_C = 10\text{pf}$		1			*		μV_{rms}

1. Doubles for every 10°C of temperature increase.
2. $+V_S$ and $-V_S$ denote the positive and negative power supply rail respectively.

GAIN

Parameter	Test Conditions	PA85			PA85A			Units
		Min	Typ	Max	Min	Typ	Max	
Open Loop, @ 15 Hz	$R_L = 2\text{K}\Omega$, $C_C = \text{Open}$	96	111		*	*		dB
Gain Bandwidth Product @ 1 MHz	$R_L = 2\text{K}\Omega$, $C_C = 3.3\text{pf}$		100			*		MHz
Power Bandwidth	$C_C = 10\text{pf}$		300			*		kHz
	$C_C = 3.3\text{pf}$		500			*		kHz
Phase Margin	Full temp range		60			*		°

OUTPUT

Parameter	Test Conditions	PA85			PA85A			Units
		Min	Typ	Max	Min	Typ	Max	
Voltage Swing ¹	$I_O = \pm 200\text{mA}$	$\pm V_S - 10$	$\pm V_S - 6.5$		*	*		V
Voltage Swing ¹	$I_O = \pm 75\text{mA}$	$\pm V_S - 8.5$	$\pm V_S - 6.0$		*	*		V
Voltage Swing ¹	$I_O = \pm 20\text{mA}$	$\pm V_S - 8.0$	$\pm V_S - 5.5$		*	*		V
Current, continuous	$T_C = 85^\circ\text{C}$	± 200			*			mA
Slew Rate, $A_V = 20$	$C_C = 10\text{pf}$		400			*		V/ μs
Slew Rate, $A_V = 100$	$C_C = \text{open}$		1000		700	*		V/ μs
Capacitive Load, $A_V = +1$	Full temp range	470			*			pf
Settling Time to 0.1%	$C_C = 10\text{pf}$, 2V step		1			*		μs
Resistance, no load	$R_{CL} = 0$		50			*		Ω

1. $+V_S$ and $-V_S$ denote the positive and negative power supply rail respectively.

POWER SUPPLY

Parameter	Test Conditions	PA85			PA85A			Units
		Min	Typ	Max	Min	Typ	Max	
Voltage ¹	Full temp range	± 15	± 150	± 225	*	*	*	V
Current, quiescent			21	25		*	*	mA

1. Derate max supply rating 0.625 V/ $^\circ\text{C}$ below 25 $^\circ\text{C}$ case. No derating needed above 25 $^\circ\text{C}$ case.

THERMAL

Parameter	Test Conditions	PA85			PA85A			Units
		Min	Typ	Max	Min	Typ	Max	
Resistance, AC, junction to case ¹	Full temp range, $F > 60\text{ Hz}$			2.5			*	$^\circ\text{C}/\text{W}$
Resistance, DC, junction to case	Full temp range, $F < 60\text{ Hz}$			4.2			*	$^\circ\text{C}/\text{W}$
Resistance, junction to air	Full temp range		30			*		$^\circ\text{C}/\text{W}$
Temperature Range, case	Meets full range specifications	-25		+85	*		*	$^\circ\text{C}$

1. Rating applies if the output current alternates between both output transistors at a rate faster than 60 Hz.

Note: * The specification of PA85A is identical to the specification for PA85 in applicable column to the left.

TYPICAL PERFORMANCE GRAPHS

Figure 3: Power Derating

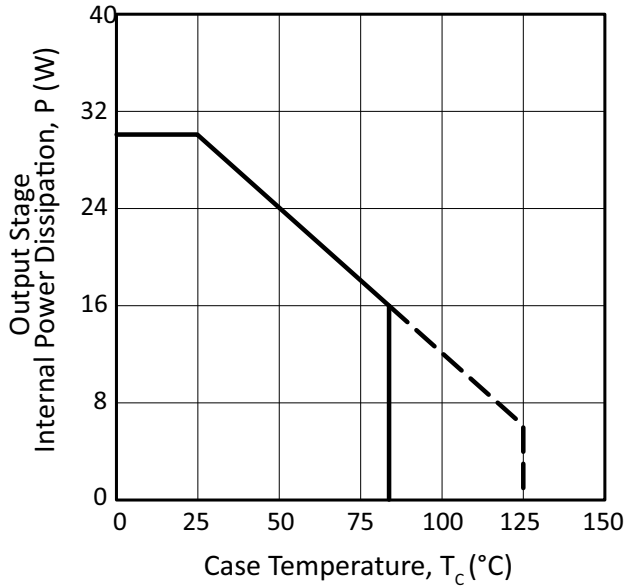

Figure 4: Quiescent Current

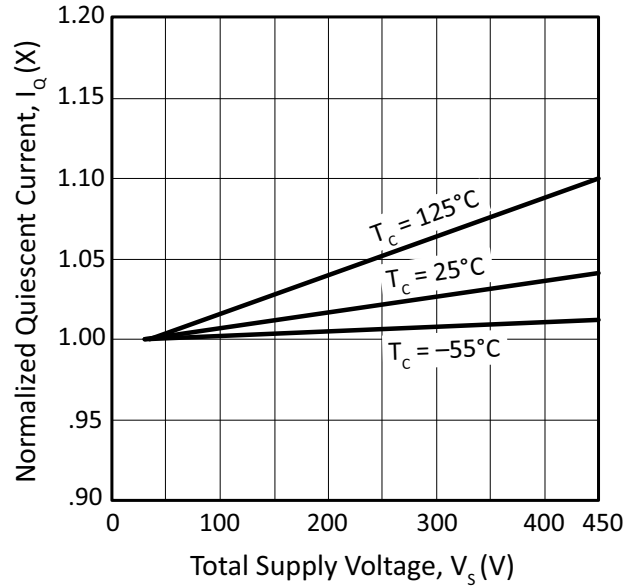

Figure 5: Small Signal Response

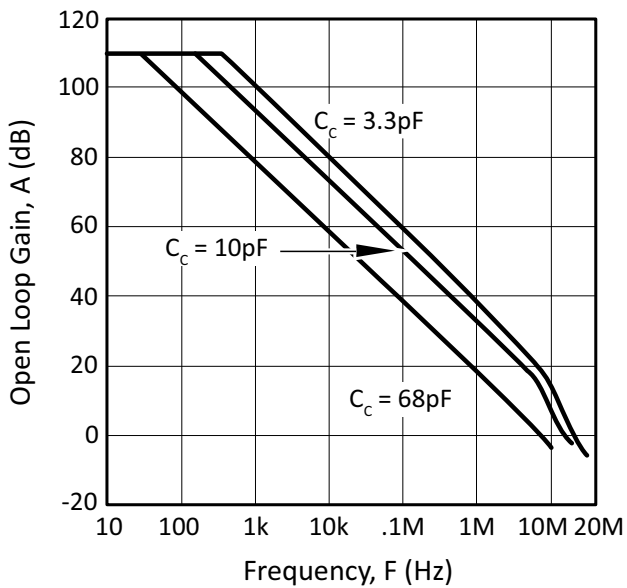

Figure 6: Phase Response

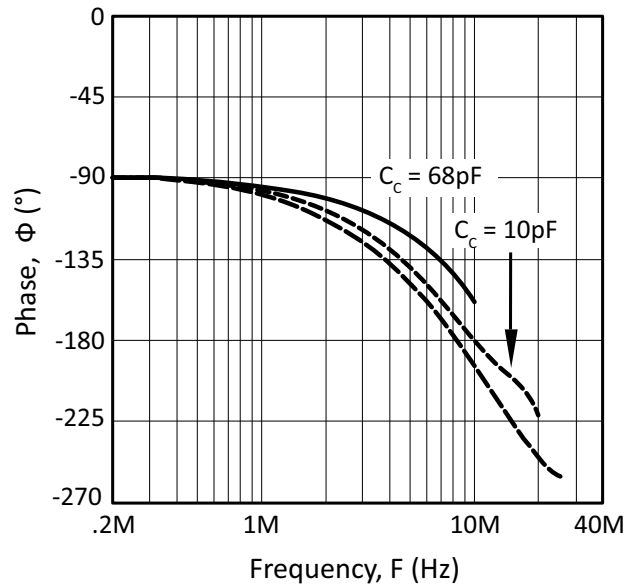

Figure 7: Output Voltage Swing

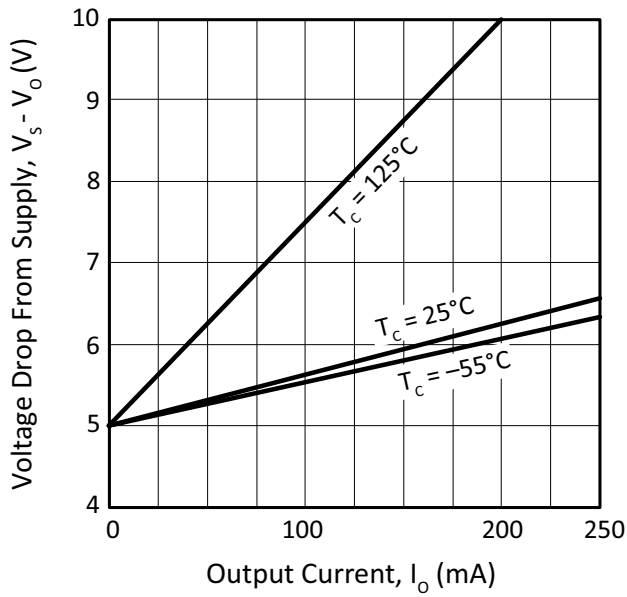

Figure 8: Power Response

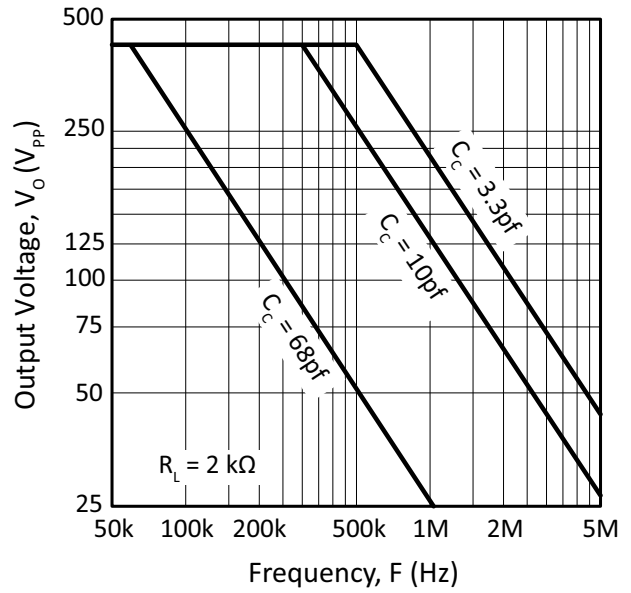

Figure 9: Slew Rate

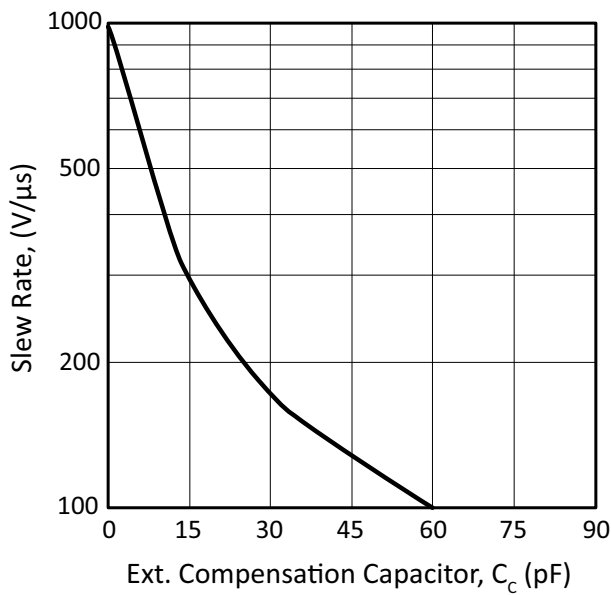

Figure 10: Harmonic Distortion

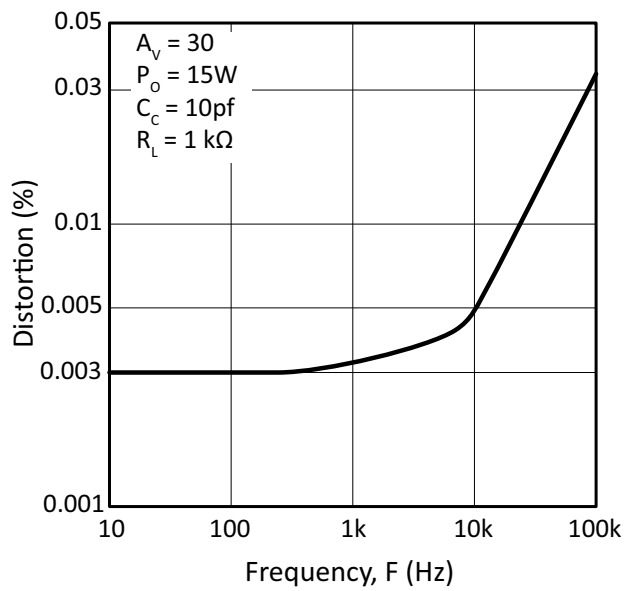

Figure 11: Input Noise Voltage

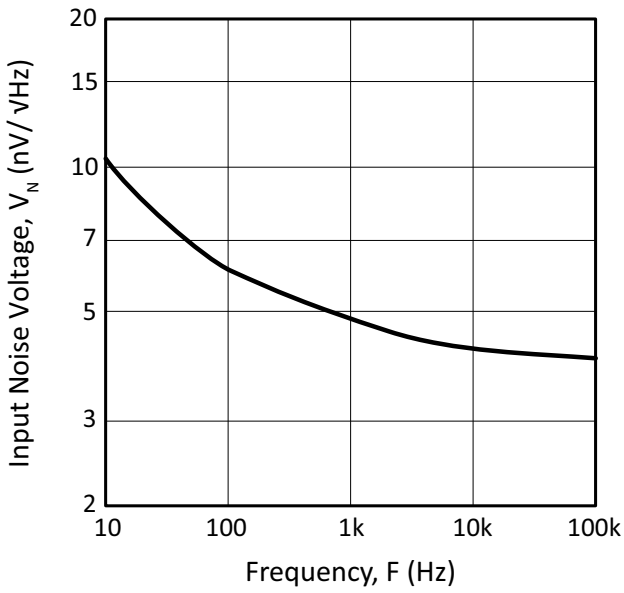

Figure 12: Common Mode Rejection

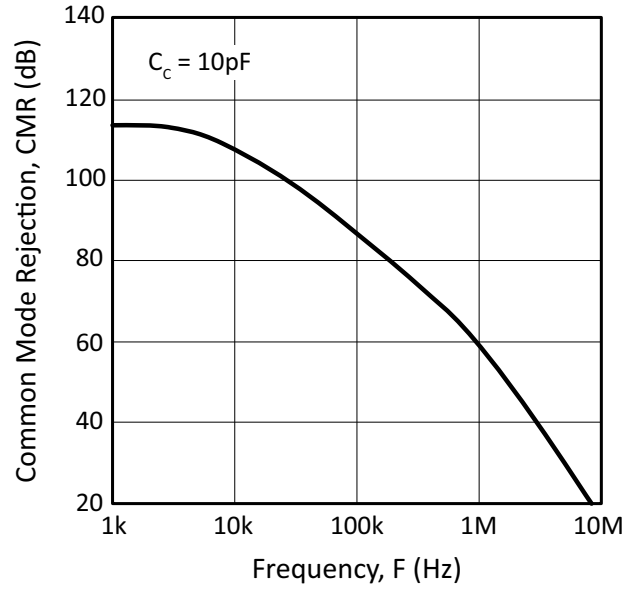

Figure 13: Power Supply Rejection

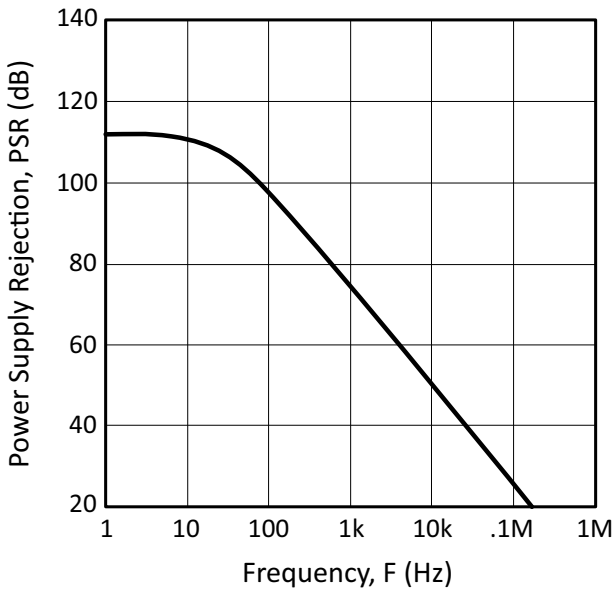
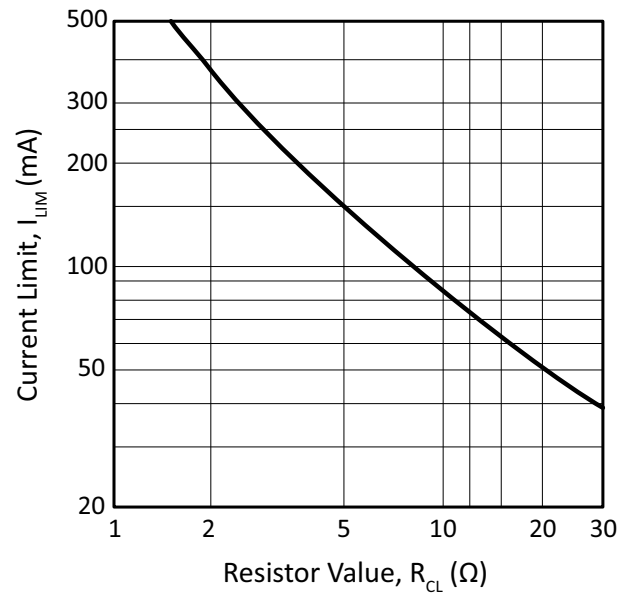

Figure 14: Current Limit



SAFE OPERATING AREA (SOA)

The safe operating area curves define the maximum additional internal power dissipation the amplifier can tolerate when it produces the necessary output to drive an external load. This is not the same as the absolute maximum internal power dissipation listed elsewhere in the specification since the quiescent power dissipation is significant compared to the total.

The MOSFET output stage of this power operational amplifier has two distinct limitations:

1. The current handling capability of the MOSFET geometry and the wire bonds.
2. The junction temperature of the output MOSFETs.

Note: The output stage is protected against transient flyback. However, for protection against sustained, high energy flyback, external fast-recovery diodes should be used.

Figure 15: SOA

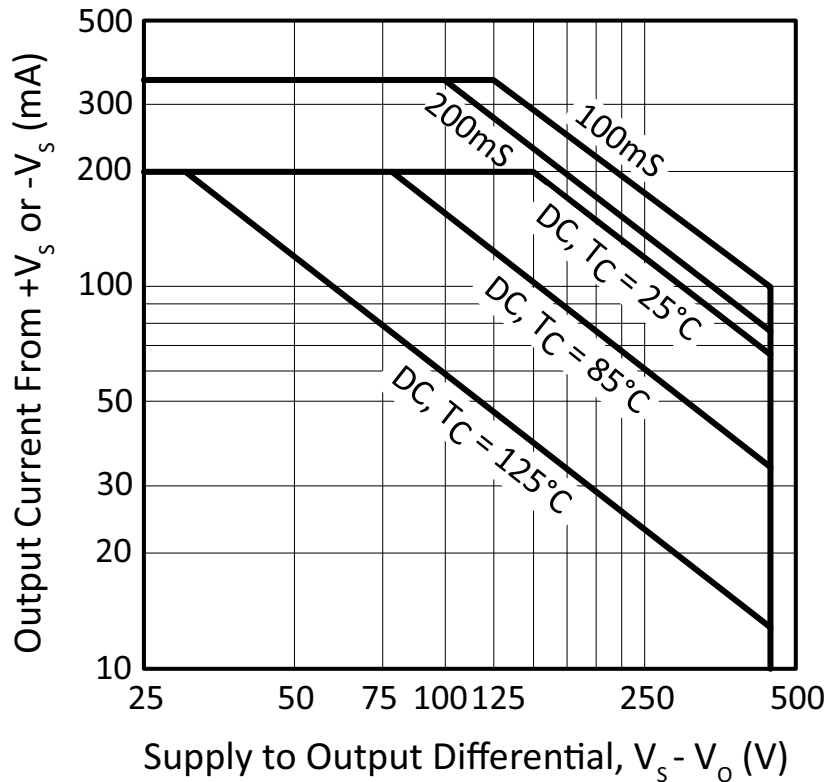

GENERAL

Please read Application Note 1 “General Operating Considerations” which covers stability, supplies, heat sinking, mounting, current limit, SOA interpretation, and specification interpretation. Visit www.apexanalog.com for Apex Microtechnology’s complete Application Notes library, Technical Seminar Workbook, and Evaluation Kits.

TYPICAL APPLICATION

Dynamic focusing is the active correction of focusing voltage as a beam traverses the face of a CRT. This is necessary in high resolution flat face monitors since the distance between cathode and screen varies as the beam moves from the center of the screen to the edges. PA85 lends itself well to this function since it can be connected as a summing amplifier with inputs from the nominal focus potential and the dynamic correction. The nominal might be derived from a potentiometer, or perhaps automatic focusing circuitry might be used to generate this potential. The dynamic correction is generated from the sweep voltages by calculating the distance of the beam from the center of the display.

Figure 16: Typical Application

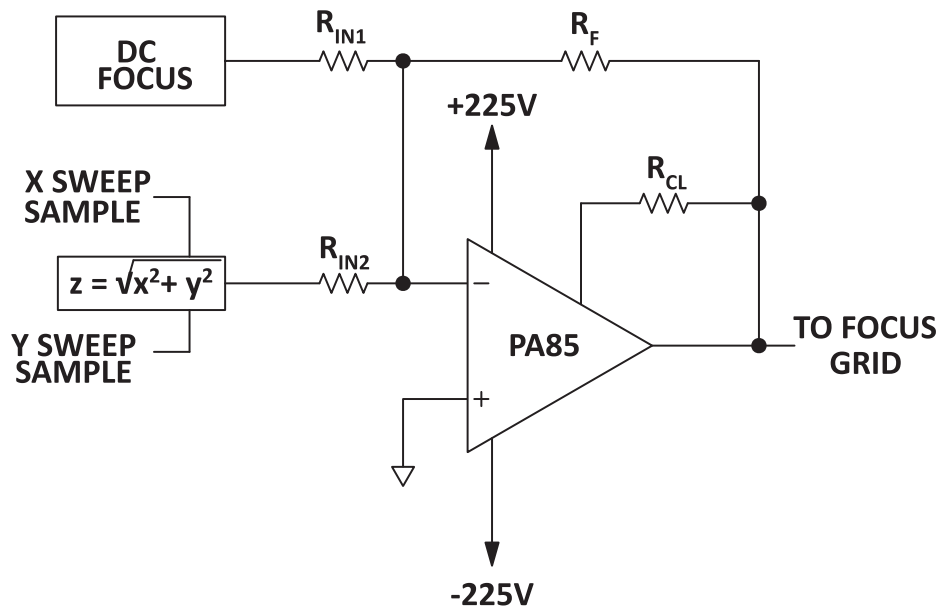

PHASE COMPENSATION

Gain	C _C *	R _C
1	68pF	100 Ω
20	10pF	330 Ω
100	3.3pF	0 Ω

*C_C rated for full supply voltage.

CURRENT LIMIT

For proper operation, the current limit resistor (R_{CL}) must be connected as shown in the typical connection diagram. The minimum value is 1.4 ohm, however for optimum reliability the resistor value should be set as high as possible. The value is calculated as follows; with the maximum practical value of 30 ohms.

$$R_{CL}(\Omega) = \frac{0.7V}{I_{LIM} - 0.016(A)}$$

INPUT PROTECTION

Although the PA85 can withstand differential voltages up to $\pm 25V$, additional external protection is recommended. Since the PA85 is a high speed amplifier, low leakage, low capacitance JFETs connected as diodes are recommended (e.g. 2N4416, Q1-Q4 in Figure 17). The differential input voltage will be clamped to $\pm 1.4V$. This is sufficient overdrive to produce maximum power bandwidth.

Figure 17: Overvoltage Protection

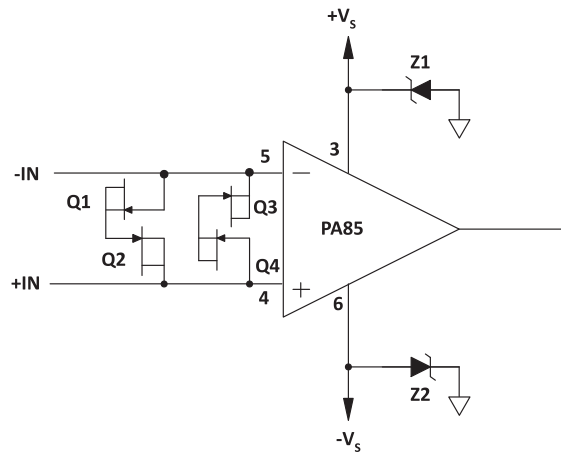

POWER SUPPLY PROTECTION

Unidirectional zener diode transient suppressors are recommended as protection on the supply pins. The zeners clamp transients to voltages within the power supply rating and also clamp power supply reversals to ground. Whether the zeners are used or not, the system power supply should be evaluated for transient performance including power-on overshoot and power-off polarity reversals as well as line regulation.

Conditions which can cause open circuits or polarity reversals on either power supply rail should be avoided or protected against. Reversals or opens on the negative supply rail is known to induce input stage failure. Unidirectional transzorbis prevent this, and it is desirable that they be both electrically and physically as close to the amplifier as possible.

STABILITY

The PA85 is externally compensated and performance can be tailored to the application. Use the graphs of small signal response and power response as a guide. The compensation capacitor C_C must be rated at 500V working voltage. An NPO capacitor is recommended. The compensation network $C_C R_C$ must be mounted closely to the amplifier pins 7 and 8 to avoid spurious oscillation.

PACKAGE OPTIONS

PACKAGE STYLE CE

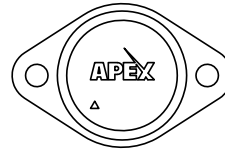
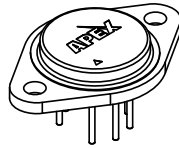

Ordinate dimensions for CAD layout

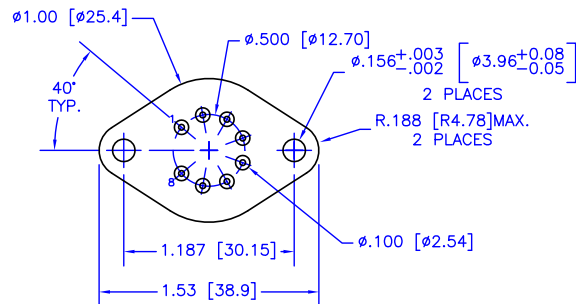
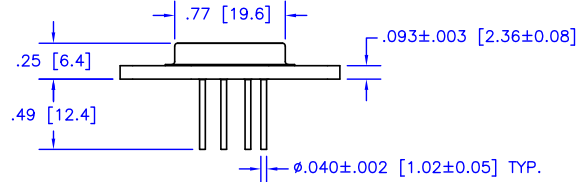
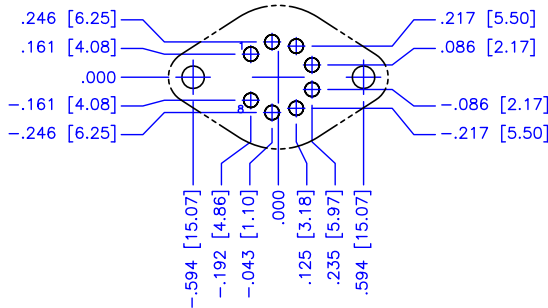

NOTES:

1. Dimensions are inches & [mm].
2. Triangle printed on lid denotes pin 1.
3. Header flatness within pin circle is .0005" TIR, max.
4. Header flatness between mounting holes is .0015" TIR, max.
5. Standard pin material: Solderable nickel-plated Alloy 52.
6. Header material: Nickel-plated cold-rolled steel.
7. Welded hermetic package seal
8. Isolation: 500 VDC any pin to case.
9. Package weight: .53 oz [15 g]

NEED TECHNICAL HELP? CONTACT APEX SUPPORT!

For all Apex Microtechnology product questions and inquiries, call toll free 800-546-2739 in North America. For inquiries via email, please contact apex.support@apexanalog.com. International customers can also request support by contacting their local Apex Microtechnology Sales Representative. To find the one nearest to you, go to www.apexanalog.com

IMPORTANT NOTICE

Apex Microtechnology, Inc. has made every effort to insure the accuracy of the content contained in this document. However, the information is subject to change without notice and is provided "AS IS" without warranty of any kind (expressed or implied). Apex Microtechnology reserves the right to make changes without further notice to any specifications or products mentioned herein to improve reliability. This document is the property of Apex Microtechnology and by furnishing this information, Apex Microtechnology grants no license, expressed or implied under any patents, mask work rights, copyrights, trademarks, trade secrets or other intellectual property rights. Apex Microtechnology owns the copyrights associated with the information contained herein and gives consent for copies to be made of the information only for use within your organization with respect to Apex Microtechnology integrated circuits or other products of Apex Microtechnology. This consent does not extend to other copying such as copying for general distribution, advertising or promotional purposes, or for creating any work for resale.

APEX MICROTECHNOLOGY PRODUCTS ARE NOT DESIGNED, AUTHORIZED OR WARRANTED TO BE SUITABLE FOR USE IN PRODUCTS USED FOR LIFE SUPPORT, AUTOMOTIVE SAFETY, SECURITY DEVICES, OR OTHER CRITICAL APPLICATIONS. PRODUCTS IN SUCH APPLICATIONS ARE UNDERSTOOD TO BE FULLY AT THE CUSTOMER OR THE CUSTOMER'S RISK.

Apex Microtechnology, Apex and Apex Precision Power are trademarks of Apex Microtechnology, Inc. All other corporate names noted herein may be trademarks of their respective holders.