

CS5258-1

8.0 A LDO 5-Pin Adjustable Linear Regulator

This new very low dropout regulator is designed to power the next generation of advanced microprocessors. To achieve very low dropout, the internal pass transistor is powered separately from the control circuitry. Furthermore, with the control and power inputs tied together, this device can be used in single supply configuration and still offer a better dropout voltage than conventional PNP–NPN based LDO regulators. In this mode the dropout is determined by the minimum control voltage.

It is supplied in a five–terminal TO–220 package, which allows for the implementation of a remote–sense pin permitting very accurate regulation of output voltage directly at the load, where it counts, rather than at the regulator. This remote sensing feature virtually eliminates output voltage variations due to load changes and resistive voltage drops. Typical load regulation measured at the sense pin is 1.0 mV for an output voltage of 2.5 V with a load step of 10 mA to 8.0 A.

The very fast transient loop response easily meets the needs of the latest microprocessors. In addition, a small capacitor on the Adjust pin will further improve the transient capabilities.

Internal protection circuitry provides for “bust–proof” operation, similar to three–terminal regulators. This circuitry, which includes overcurrent, short circuit, supply sequencing and overtemperature protection, will self protect the regulator under all fault conditions.

The CS5258–1 is ideal for generating a secondary 2.0–2.5 V low voltage supply on a motherboard where both 5.0 V and 3.3 V are already available.

Features

- 1.25 V to 5.0 V V_{OUT} at 8.0 A
- V_{POWER} Dropout < 0.4 V @ 8.0 A
- $V_{CONTROL}$ Dropout < 1.15 V @ 8.0 A
- 1.5% Trimmed Reference
- Fast Transient Response
- Remote Voltage Sensing
- Thermal Shutdown
- Current Limit
- Short Circuit Protection
- Backwards Compatible with 3–Pin Regulators



ON Semiconductor®

<http://onsemi.com>



Tab = V_{OUT}
Pin 1. V_{SENSE}
2. Adjust
3. V_{OUT}
4. $V_{CONTROL}$
5. V_{POWER}

TO-220
FIVE LEAD
T SUFFIX
CASE 314D

MARKING DIAGRAM



A = Assembly Location
WL, L = Wafer Lot
YY, Y = Year
WW, W = Work Week

ORDERING INFORMATION

Device	Package	Shipping
CS5258–1GT5	TO–220 FIVE LEAD	50 Units/Rail

CS5258-1

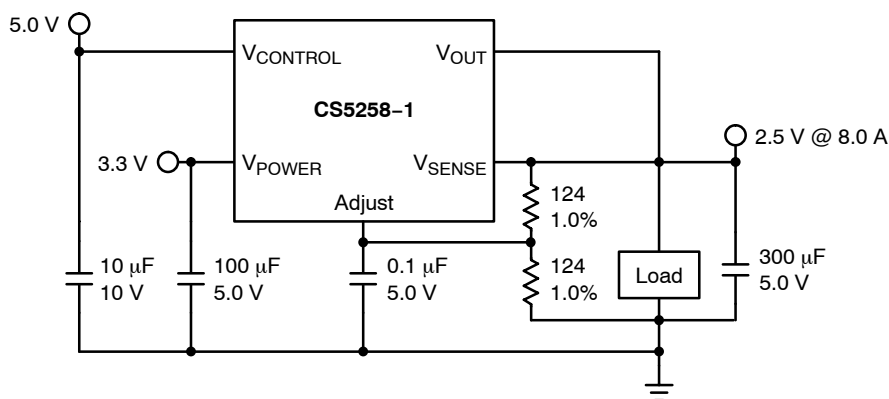

Figure 1. Application Diagram

MAXIMUM RATINGS*

Rating	Value	Unit
V _{POWER} Input Voltage	6.0	V
V _{CONTROL} Input Voltage	13	V
Operating Junction Temperature Range, T _J	0 to 150	°C
Storage Temperature Range	-65 to +150	°C
ESD Damage Threshold	2.0	kV
Lead Temperature Soldering:	Wave Solder (through hole styles only) Note 1	260 peak

1. 10 second maximum.

*The maximum package power dissipation must be observed.

ELECTRICAL CHARACTERISTICS (0°C ≤ T_A ≤ 70°C; 0°C ≤ T_J ≤ 150°C; V_{SENSE} = V_{OUT} and V_{ADJ} = 0 V; unless otherwise specified.)

Characteristic	Test Conditions	Min	Typ	Max	Unit
CS5258-1					
Reference Voltage	V _{CONTROL} = 2.75 V to 12 V, V _{POWER} = 2.15 V to 5.5 V, 10 mA ≤ I _{OUT} ≤ 8.0 A	1.234 (-1.5%)	1.253	1.272 (+1.5%)	V
Line Regulation	V _{CONTROL} = 2.5 V to 12 V, V _{POWER} = 1.75 V to 5.5 V, I _{OUT} = 10 mA	-	0.02	0.2	%
Load Regulation (Note 2)	V _{CONTROL} = 2.75 V, V _{POWER} = 2.15 V, I _{OUT} = 10 mA to 8.0 A, with Remote Sense	-	0.04	0.2	%
Minimum Load Current (Note 3)	V _{CONTROL} = 5.0 V, V _{POWER} = 3.3 V, ΔV _{OUT} = +1.0%	-	5.0	10	mA
Control Pin Current (Note 4)	V _{CONTROL} = 2.75 V, V _{POWER} = 2.15 V, I _{OUT} = 100 mA	-	6.0	10	mA
	V _{CONTROL} = 2.75 V, V _{POWER} = 2.15 V, I _{OUT} = 4.0 A	-	30	60	mA
	V _{CONTROL} = 2.75 V, V _{POWER} = 1.75 V, I _{OUT} = 4.0 A	-	33	70	mA
	V _{CONTROL} = 2.75 V, V _{POWER} = 2.15 V, I _{OUT} = 8.0 A	-	80	180	mA
Adjust Pin Current	V _{CONTROL} = 2.75 V, V _{POWER} = 2.15 V, I _{OUT} = 10 mA	-	60	120	µA
Current Limit	V _{CONTROL} = 2.75 V, V _{POWER} = 2.15 V, ΔV _{OUT} = -1.5%	8.1	10	-	A
Short Circuit Current	V _{CONTROL} = 2.75 V, V _{POWER} = 2.15 V, V _{OUT} = 0 V	6.0	9.0	-	A

2. This parameter is guaranteed by design and is not 100% production tested.

3. The minimum load current is the minimum current required to maintain regulation. Normally the current in the resistor divider used to set the output voltage is selected to meet the minimum load current requirement.

4. The V_{CONTROL} pin current is the drive current required for the output transistor. This current will track output current with roughly a 1:100 ratio. The minimum value is equal to the quiescent current of the device.

CS5258-1

ELECTRICAL CHARACTERISTICS (continued) ($0^{\circ}\text{C} \leq T_A \leq 70^{\circ}\text{C}$; $0^{\circ}\text{C} \leq T_J \leq 150^{\circ}\text{C}$; $V_{\text{SENSE}} = V_{\text{OUT}}$ and $V_{\text{ADJ}} = 0\text{ V}$; unless otherwise specified.)

Characteristic	Test Conditions	Min	Typ	Max	Unit
CS5258-1					
Ripple Rejection (Note 5)	$V_{\text{CONTROL}} = V_{\text{POWER}} = 3.25\text{ V Avg}$ $V_{\text{RIPPLE}} = 1.0\text{ V}_{\text{P-P}} @ 120\text{ Hz}$, $I_{\text{OUT}} = 4.0\text{ A}$, $C_{\text{ADJ}} = 0.1\text{ }\mu\text{F}$	60	80	-	dB
Thermal Regulation	30 ms Pulse, $T_A = 25^{\circ}\text{C}$	-	0.002	-	%/W
V_{CONTROL} Dropout Voltage (Minimum $V_{\text{CONTROL}} - V_{\text{OUT}}$) (Note 6)	$V_{\text{POWER}} = 2.15\text{ V}$, $I_{\text{OUT}} = 100\text{ mA}$	-	1.00	1.15	V
	$V_{\text{POWER}} = 2.15\text{ V}$, $I_{\text{OUT}} = 1.0\text{ A}$	-	1.00	1.15	V
	$V_{\text{POWER}} = 2.15\text{ V}$, $I_{\text{OUT}} = 2.75\text{ A}$	-	1.00	1.15	V
	$V_{\text{POWER}} = 2.15\text{ V}$, $I_{\text{OUT}} = 4.0\text{ mA}$	-	1.00	1.15	V
	$V_{\text{POWER}} = 2.15\text{ V}$, $I_{\text{OUT}} = 8.0\text{ A}$	-	1.15	1.30	V
V_{POWER} Dropout Voltage (Minimum $V_{\text{POWER}} - V_{\text{OUT}}$) (Note 6)	$V_{\text{CONTROL}} = 2.75\text{ V}$, $I_{\text{OUT}} = 100\text{ mA}$	-	0.10	0.15	V
	$V_{\text{CONTROL}} = 2.75\text{ V}$, $I_{\text{OUT}} = 1.0\text{ A}$	-	0.15	0.20	V
	$V_{\text{CONTROL}} = 2.75\text{ V}$, $I_{\text{OUT}} = 2.75\text{ A}$	-	0.20	0.30	V
	$V_{\text{CONTROL}} = 2.75\text{ V}$, $I_{\text{OUT}} = 4.0\text{ mA}$	-	0.26	0.40	V
	$V_{\text{CONTROL}} = 2.75\text{ V}$, $I_{\text{OUT}} = 8.0\text{ A}$	-	0.40	0.70	V
RMS Output Noise	Freq = 10 Hz to 10 kHz, $T_A = 25^{\circ}\text{C}$	-	0.003	-	% V_{OUT}
Temperature Stability	-	-	0.5	-	%
Thermal Shutdown (Note 7)	-	150	180	210	$^{\circ}\text{C}$
Thermal Shutdown Hysteresis	-	-	25	-	$^{\circ}\text{C}$
V_{CONTROL} Supply Only Output Current	$V_{\text{CONTROL}} = 13\text{ V}$, V_{POWER} Not Connected, $V_{\text{ADJ}} = V_{\text{OUT}} = V_{\text{SENSE}} = 0\text{ V}$	-	-	50	mA
V_{POWER} Supply Only Output Current	$V_{\text{POWER}} = 6.0\text{ V}$, V_{CONTROL} Not Connected, $V_{\text{ADJ}} = V_{\text{OUT}} = V_{\text{SENSE}} = 0\text{ V}$	-	0.1	1.0	mA

- This parameter is guaranteed by design and is not 100% production tested.
- Dropout is defined as either minimum control voltage (V_{CONTROL}) or minimum power voltage (V_{POWER}) to output voltage differential required to maintain 1.5% regulation at a particular load.
- This parameter is guaranteed by design, but not parametrically tested in production. However, a 100% thermal shutdown functional test is performed on each part.

PACKAGE PIN DESCRIPTION

PACKAGE PIN #	PIN SYMBOL	FUNCTION
TO-220		
1	V_{SENSE}	This Kelvin sense pin allows for remote sensing of the output voltage at the load for improved regulation. It is internally connected to the positive input of the voltage sensing error amplifier.
2	Adjust	This pin is connected to the low side of the internally trimmed 1.5% bandgap reference voltage and carries a bias current of about 50 μA . A resistor divider from Adjust to V_{OUT} and from Adjust to ground sets the output voltage. Also, transient response can be improved by adding a small bypass capacitor from this pin to ground.
3	V_{OUT}	This pin is connected to the emitter of the power pass transistor and provides a regulated voltage capable of sourcing 8.0 A of current.
4	V_{CONTROL}	This is the supply voltage for the regulator control circuitry. For the device to regulate, this voltage should be between 1.0 V and 1.3 V (depending on the output current) greater than the output voltage. The control pin current will be about 1.0% of the power pin output current.
5	V_{POWER}	This is the power input voltage. This pin is physically connected to the collector of the power pass transistor. For the device to regulate, this voltage should be between 0.1 V and 0.7 V greater than the output voltage depending on the output current. The output load current of 8.0 A is supplied through this pin.

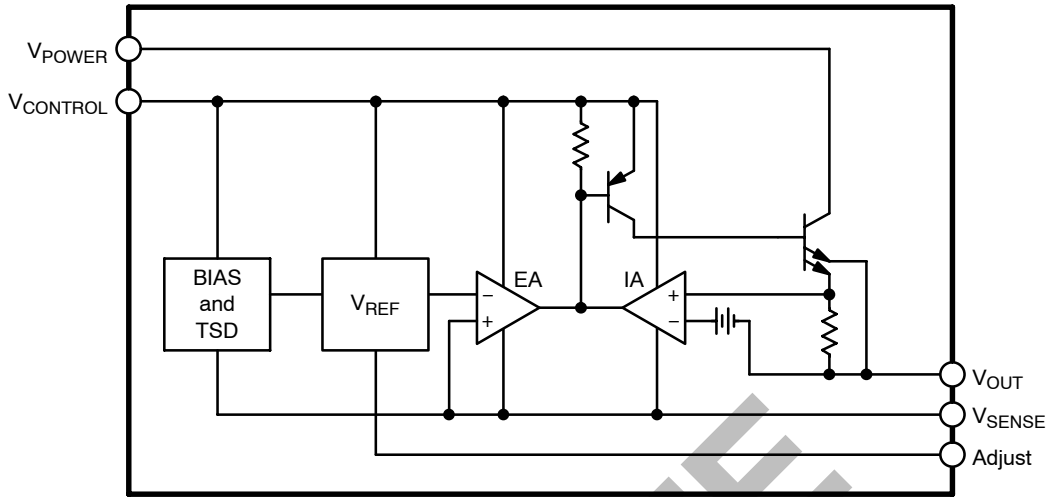

Figure 2. Block Diagram

TYPICAL PERFORMANCE CHARACTERISTICS

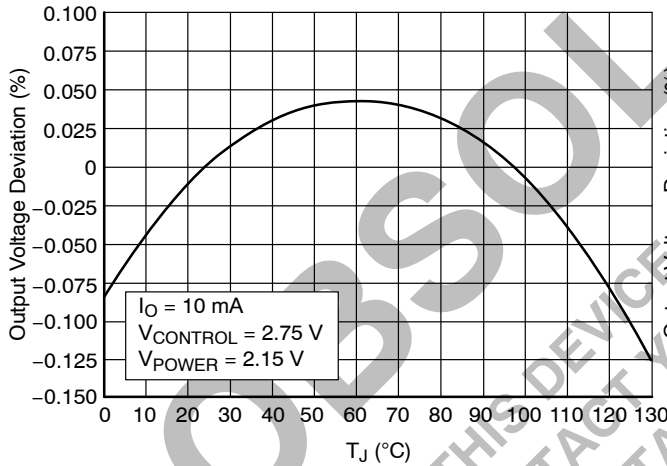

Figure 3. Reference Voltage vs Temperature

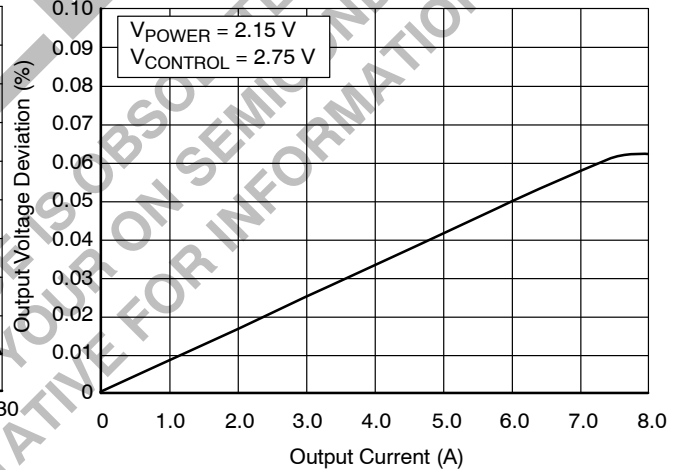

Figure 4. Reference Voltage vs Temperature

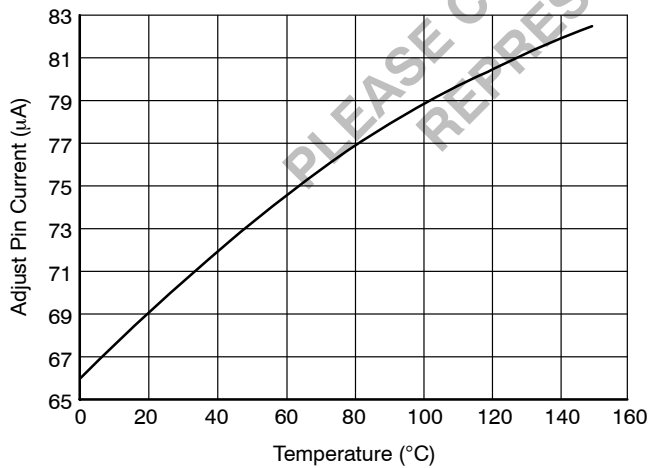

Figure 5. Adjust Pin Current vs Temperature

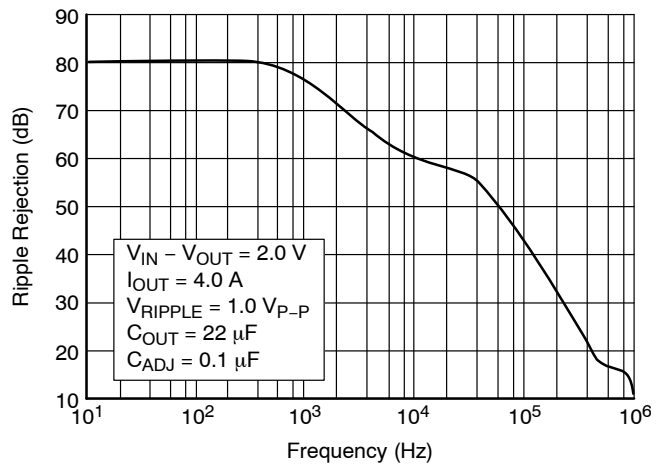

Figure 6. Ripple Rejection vs Frequency

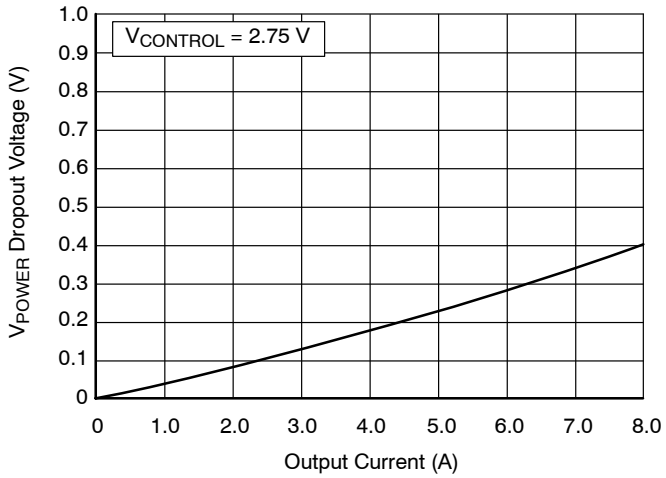

Figure 7. V_{POWER} Dropout Voltage vs I_{OUT}

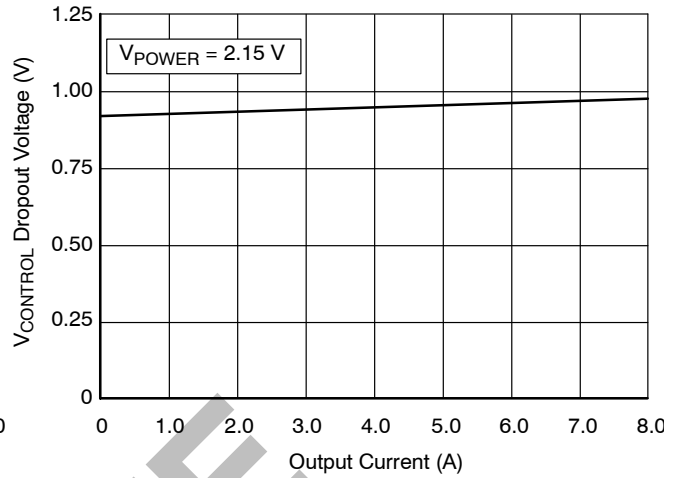

Figure 8. $V_{CONTROL}$ Dropout vs I_{OUT}

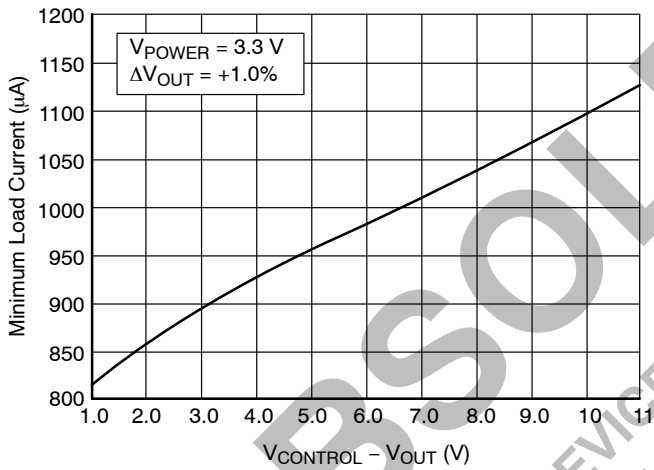

Figure 9. Minimum Load Current vs $V_{CONTROL} - V_{OUT}$

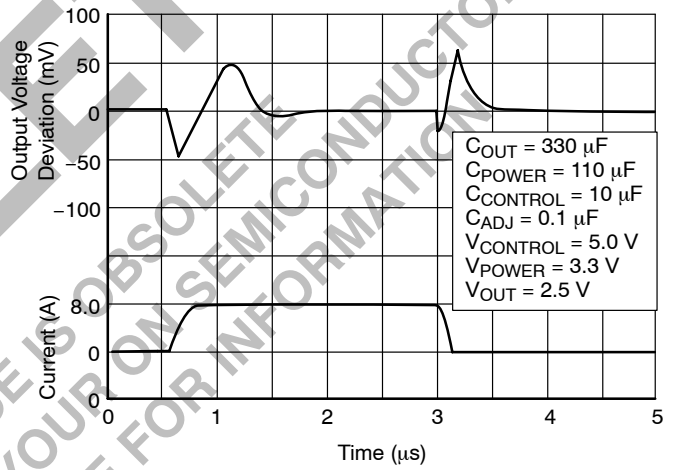

Figure 10. Current Step Transient Response

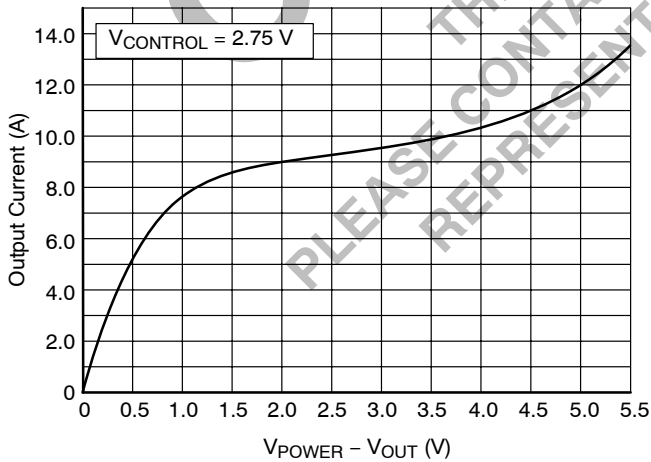

Figure 11. Short Circuit Current vs $V_{POWER} - V_{OUT}$

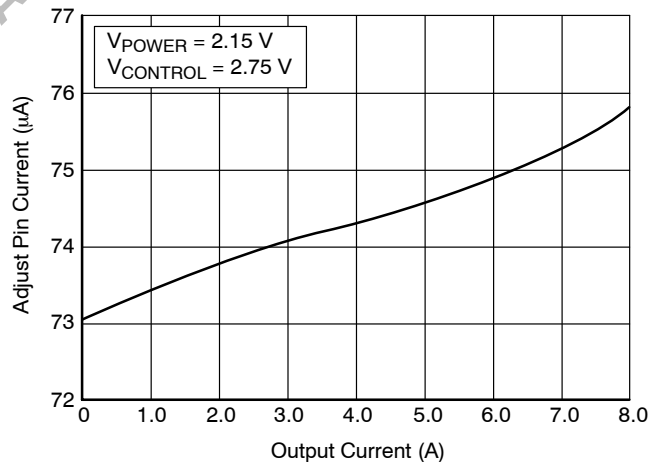
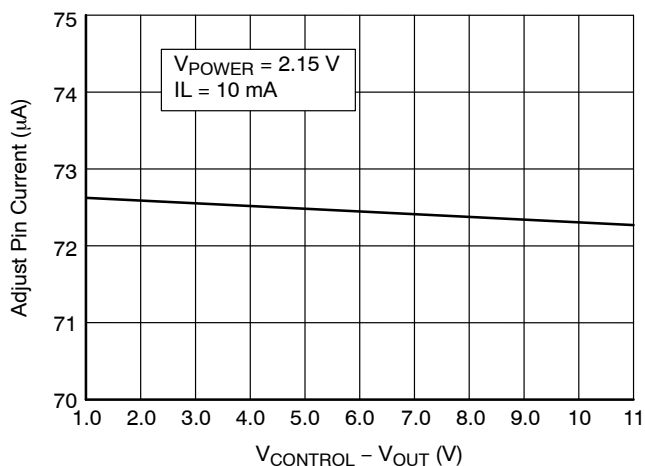
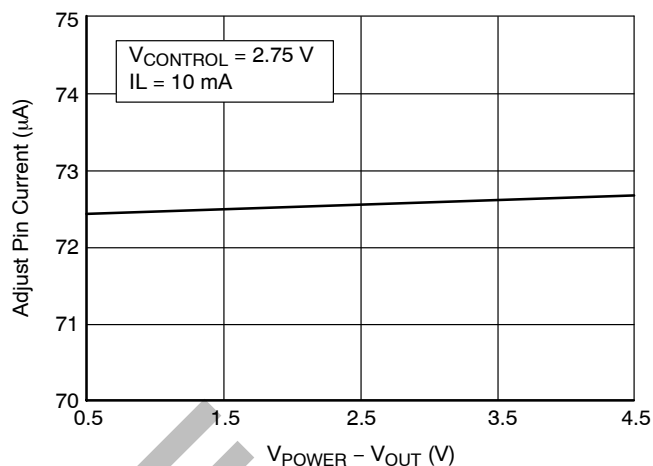
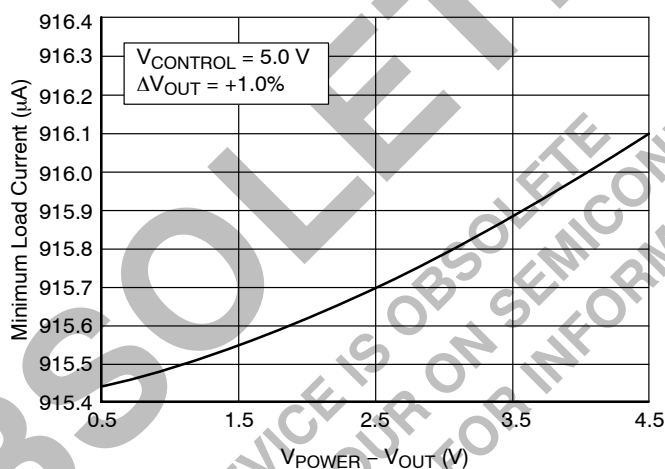

Figure 12. Adjust Pin Current vs Output Current

Figure 13. Adjust Pin Current vs $V_{CONTROL} - V_{OUT}$ Figure 14. Adjust Pin Current vs $V_{POWER} - V_{OUT}$ Figure 15. Minimum Load Current vs $V_{POWER} - V_{OUT}$

APPLICATIONS NOTES

THEORY OF OPERATION

The CS5258-1 linear regulator provides adjustable voltages from 1.25 V to 5.0 V at currents up to 8.0 A. The regulator is protected against short circuits, and includes a thermal shutdown circuit with hysteresis. The output, which is current limited, consists of a PNP-NPN transistor pair and requires an output capacitor for stability. A detailed procedure for selecting this capacitor is included in the Stability Considerations section.

V_{POWER} Function

The CS5258-1 utilizes a two supply approach to maximize efficiency. The collector of the power device is brought out to the V_{POWER} pin to minimize internal power dissipation under high current loads. $V_{CONTROL}$ provides power for the control circuitry and the drive for the output NPN transistor. $V_{CONTROL}$ should be at least 1.0 V greater than the output voltage. Special care has been taken to ensure

that there are no supply sequencing problems. The output voltage will not turn on until both supplies are operating. If the control voltage comes up first, the output current will be typically limited to about 3.0 mA until the power input voltage comes up. If the power input voltage comes up first the output will not turn on at all until the control voltage comes up. The output can never come up unregulated.

The CS5258-1 can also be used as a single supply device with the control and power inputs tied together. In this mode, the dropout will be determined by the minimum control voltage.

Output Voltage Sensing

The CS5258-1 five terminal linear regulator includes a dedicated V_{SENSE} function. This allows for true Kelvin sensing of the output voltage. This feature can virtually eliminate errors in the output voltage due to load regulation. Regulation will be optimized at the point where the sense pin is tied to the output.

DESIGN GUIDELINES

Adjustable Operation

This LDO adjustable regulator has an output voltage range of 1.25 V to 5.0 V. An external resistor divider sets the output voltage as shown in Figure 16. The regulator's voltage sensing error amplifier maintains a fixed 1.253V reference between the output pin and the adjust pin.

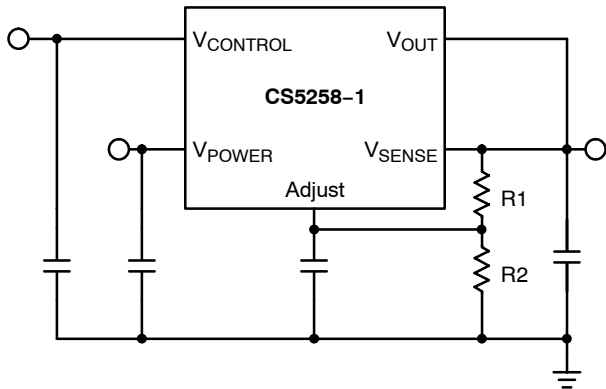

Figure 16. An External Resistor Divider Sets the Value of V_{OUT} . The 1.253 V Reference Voltage Drops Across R1.

A resistor divider network R1 and R2 causes a fixed current to flow to ground. This current creates a voltage across R2 that adds to the 1.253 V across R1 and sets the overall output voltage. The adjust pin current (typically 50 μ A) also flows through R2 and adds a small error that should be taken into account if precise adjustment of V_{OUT} is necessary. The output voltage is set according to the formula:

$$V_{OUT} = 1.253 \text{ V} \times \frac{R1 + R2}{R1} + R2 \times I_{ADJ}$$

The term $I_{ADJ} \times R2$ represents the error added by the adjust pin current.

R1 is chosen so that the minimum load current is a least 10 mA. R1 and R2 should be of the same composition for best tracking over temperature. The divider resistors should be located as close to the load as possible.

While not required, a bypass capacitor connected between the adjust pin and ground will improve transient response and ripple rejection. A 0.1 μ F tantalum capacitor is recommended for "first cut" design. Value and type may be varied to optimize performance vs. price.

Other Adjustable Operation Considerations

The CS5258-1 linear regulator has an absolute maximum specification of 6.0 V for the voltage difference between V_{IN} and V_{OUT} . However, the IC may be used to regulate voltages in excess of 6.0 V. The two main considerations in such a design are the sequencing of power supplies and short circuit capability.

Power supply sequencing should be such that the $V_{CONTROL}$ supply is brought up coincidentally with or

before the V_{POWER} supply. This allows the IC to begin charging the output capacitor as soon as the V_{POWER} to V_{OUT} differential is large enough that the pass transistor conducts. As V_{POWER} increases, the pass transistor will remain in dropout, and current is passed to the load until V_{OUT} is in regulation. Further increase in the supply voltage brings the pass transistor out of dropout. In this manner, any output voltage less than 13 V may be regulated, provided the V_{POWER} to V_{OUT} differential is less than 6.0 V. In the case where $V_{CONTROL}$ and V_{POWER} are shorted, there is no theoretical limit to the regulated voltage as long as the V_{POWER} to V_{OUT} differential of 6.0 V is not exceeded.

There is a possibility of damaging the IC when $V_{POWER} - V_{IN}$ is greater than 6.0 V if a short circuit occurs. Short circuit conditions will result in the immediate operation of the pass transistor outside of its safe operating area. Overvoltage stresses will then cause destruction of the pass transistor before overcurrent or thermal shutdown circuitry can become active. Additional circuitry may be required to clamp the V_{POWER} to V_{OUT} differential to less than 6.0 V if fail safe operation is required. One possible clamp circuit is illustrated in Figure 17; however, the design of clamp circuitry must be done on an application by application basis. Care must be taken to ensure the clamp actually protects the design. Components used in the clamp design must be able to withstand the short circuit condition indefinitely while protecting the IC.

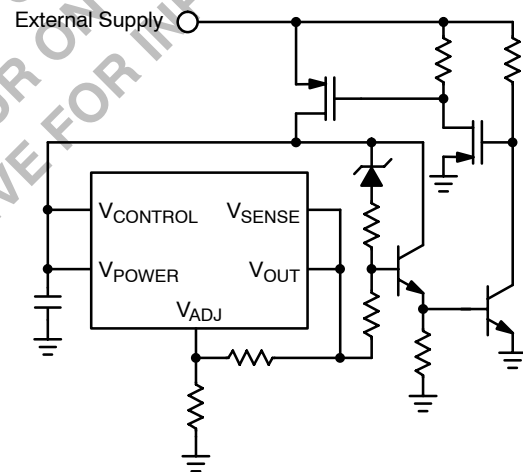

Figure 17. Example Clamp Circuitry for $V_{POWER} - V_{OUT} > 6.0 \text{ V}$

Stability Considerations

The output compensation capacitor helps determine three main characteristics of a linear regulator: start-up delay, load transient response, and loop stability.

The capacitor value and type is based on cost, availability, size and temperature constraints. A tantalum or aluminum electrolytic capacitor is best, since a film or ceramic capacitor with almost zero ESR can cause instability. The aluminum electrolytic capacitor is the least expensive

solution. However, when the circuit operates at low temperatures, both the value and ESR of the capacitor will vary considerably. The capacitor manufacturer's data sheet provides this information.

A 300 μF tantalum capacitor will work for most applications, but with high current regulators such as the CS5258-1 the transient response and stability improve with higher values of capacitor. The majority of applications for this regulator involve large changes in load current so the output capacitor must supply the instantaneous load current. The ESR of the output capacitor causes an immediate drop in output voltage given by:

$$\Delta V = \Delta I \times \text{ESR}$$

For microprocessor applications it is customary to use an output capacitor network consisting of several tantalum and ceramic capacitors in parallel. This reduces the overall ESR and reduces the instantaneous output voltage drop under transient load conditions. The output capacitor network should be as close to the load as possible for the best results.

Protection Diodes

When large external capacitors are used with a linear regulator it is sometimes necessary to add protection diodes. If the input voltage of the regulator gets shorted, the output capacitor will discharge into the output of the regulator. The discharge current depends on the value of the capacitor, the output voltage, and the rate at which V_{CONTROL} drops. In the CS5258-1 regulator, the discharge path is through a large junction and protection diodes are not usually needed. If the regulator is used with large values of output capacitance and the input voltage is instantaneously shorted to ground, damage can occur. In this case, a diode connected as shown in Figure 18 is recommended. Use of the diode has the added benefit of bleeding V_{OUT} to ground if V_{CONTROL} is shorted. This prevents an unregulated output from causing system damage.

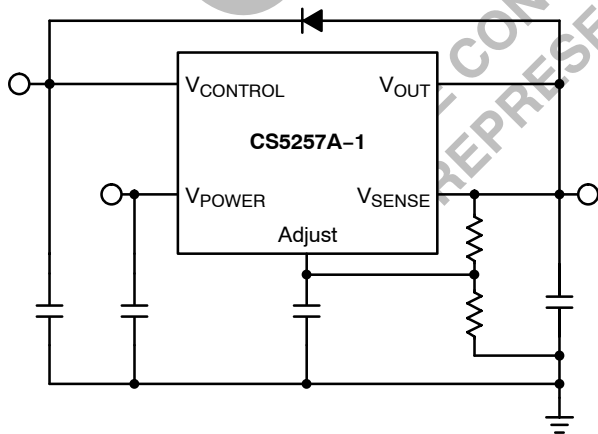

Figure 18. Diode Protection Against V_{CONTROL} Short Circuit Conditions

A rule of thumb useful in determining if a protection diode is required is to solve for current

$$I = \frac{C \times V}{T}$$

where:

I is the current flow out of the load capacitance when V_{CONTROL} is shorted,

C is the value of load capacitance,

V is the output voltage, and

T is the time duration required for V_{CONTROL} to transition from high to being shorted.

If the calculated current is greater than or equal to the typical short circuit current value provided in the specifications, serious thought should be given to the use of a protection diode.

Current Limit

The internal current limit circuit limits the output current under excessive load conditions.

Short Circuit Protection

The device includes short circuit protection circuitry that clamps the output current at approximately two amperes less than its current limit value. This provides for a current foldback function, which reduces power dissipation even further under a direct shorted load.

Thermal Shutdown

The thermal shutdown circuitry is guaranteed by design to activate above a die junction temperature of approximately 150°C and to shut down the regulator output. This circuitry has 25°C of typical hysteresis, thereby allowing the regulator to recover from a thermal fault automatically.

Calculating Power Dissipation and Heat Sink Requirements

High power regulators such as the CS5258-1 family usually operate at high junction temperatures. Therefore, it is important to calculate the power dissipation and junction temperatures accurately to ensure that an adequate heat sink is used. Since the package tab is connected to V_{OUT} on the CS5258-1, electrical isolation may be required for some applications. Also, as with all high power packages, thermal compound is necessary to ensure proper heat flow. For added safety, this high current LDO includes an internal thermal shutdown circuit.

The thermal characteristics of an IC depend on the following four factors: junction temperature, ambient temperature, die power dissipation, and the thermal resistance from the die junction to ambient air. The maximum junction temperature can be determined by:

$$T_{\text{J(max)}} = T_{\text{A(max)}} + \text{PD(max)} \times R_{\theta\text{JA}}$$

The maximum ambient temperature and the power dissipation are determined by the design while the maximum junction temperature and the thermal resistance depend on the manufacturer and the package type. The maximum power dissipation for a regulator is:

$$PD_{(max)} = (V_{IN(max)} - V_{OUT(min)})I_{OUT(max)} + V_{IN(max)} \times I_{IN(max)}$$

A heat sink effectively increases the surface area of the package to improve the flow of heat away from the IC and into the surrounding air. Each material in the heat flow path between the IC and the outside environment has a thermal resistance which is measured in degrees per watt. Like series electrical resistances, these thermal resistances are summed to determine the total thermal resistance between the die junction and the surrounding air, $R_{\theta JA}$. This total thermal resistance is comprised of three components. These resistive terms are measured from junction to case ($R_{\theta JC}$), case to heat sink ($R_{\theta CS}$), and heat sink to ambient air ($R_{\theta SA}$). The equation is:

$$R_{\theta JA} = R_{\theta JC} + R_{\theta CS} + R_{\theta SA}$$

The value for $R_{\theta JC}$ is 1.4°C/watt for the CS5258-1 in the TO-220 package. For a high current regulator such as the CS5258-1 the majority of heat is generated in the power transistor section. The value for $R_{\theta SA}$ depends on the heat sink type, while the $R_{\theta CS}$ depends on factors such as package type, heat sink interface (is an insulator and thermal grease used?), and the contact area between the heat sink and the package. Once these calculations are complete, the maximum permissible value of $R_{\theta JA}$ can be calculated and the proper heat sink selected. For further discussion on heat sink selection, see our application note "Thermal Management," document number AND8036/D, available through the Literature Distribution Center or via our website at <http://www.onsemi.com>.

OBSOLETE
 THIS DEVICE IS OBSOLETE
 PLEASE CONTACT YOUR ON SEMICONDUCTOR
 REPRESENTATIVE FOR INFORMATION

CS5258-1

PACKAGE DIMENSIONS

TO-220
FIVE LEAD
T SUFFIX
CASE 314D-04
ISSUE E

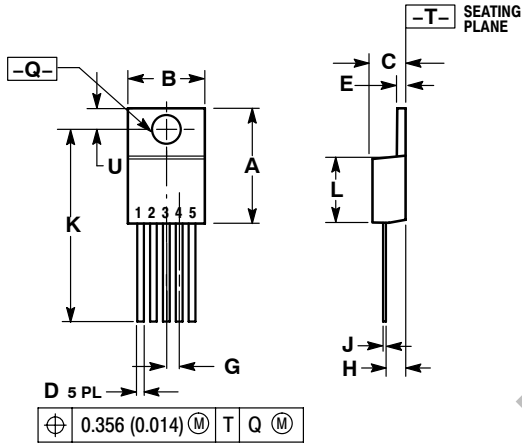

NOTES:

1. DIMENSIONING AND TOLERANCING PER ANSI Y14.5M, 1982.
2. CONTROLLING DIMENSION: INCH.
3. DIMENSION D DOES NOT INCLUDE INTERCONNECT BAR (DAMBAR) PROTRUSION. DIMENSION D INCLUDING PROTRUSION SHALL NOT EXCEED 10.92 (0.043) MAXIMUM.

DIM	INCHES		MILLIMETERS	
	MIN	MAX	MIN	MAX
A	0.572	0.613	14.529	15.570
B	0.390	0.415	9.906	10.541
C	0.170	0.180	4.318	4.572
D	0.025	0.038	0.635	0.965
E	0.048	0.055	1.219	1.397
G	0.067 BSC		1.702 BSC	
H	0.087	0.112	2.210	2.845
J	0.015	0.025	0.381	0.635
K	0.990	1.045	25.146	26.543
L	0.320	0.365	8.128	9.271
Q	0.140	0.153	3.556	3.886
U	0.105	0.117	2.667	2.972

PACKAGE THERMAL DATA

Parameter		TO-220 Five Lead	Unit
R _{θJC}	Typical	1.4	°C/W
R _{θJA}	Typical	50	°C/W

ON Semiconductor and  are registered trademarks of Semiconductor Components Industries, LLC (SCILLC). SCILLC reserves the right to make changes without further notice to any products herein. SCILLC makes no warranty, representation or guarantee regarding the suitability of its products for any particular purpose, nor does SCILLC assume any liability arising out of the application or use of any product or circuit, and specifically disclaims any and all liability, including without limitation special, consequential or incidental damages. "Typical" parameters which may be provided in SCILLC data sheets and/or specifications can and do vary in different applications and actual performance may vary over time. All operating parameters, including "Typicals" must be validated for each customer application by customer's technical experts. SCILLC does not convey any license under its patent rights nor the rights of others. SCILLC products are not designed, intended, or authorized for use as components in systems intended for surgical implant into the body, or other applications intended to support or sustain life, or for any other application in which the failure of the SCILLC product could create a situation where personal injury or death may occur. Should Buyer purchase or use SCILLC products for any such unintended or unauthorized application, Buyer shall indemnify and hold SCILLC and its officers, employees, subsidiaries, affiliates, and distributors harmless against all claims, costs, damages, and expenses, and reasonable attorney fees arising out of, directly or indirectly, any claim of personal injury or death associated with such unintended or unauthorized use, even if such claim alleges that SCILLC was negligent regarding the design or manufacture of the part. SCILLC is an Equal Opportunity/Affirmative Action Employer. This literature is subject to all applicable copyright laws and is not for resale in any manner.

PUBLICATION ORDERING INFORMATION

LITERATURE FULFILLMENT:
Literature Distribution Center for ON Semiconductor
P.O. Box 5163, Denver, Colorado 80217 USA
Phone: 303-675-2175 or 800-344-3860 Toll Free USA/Canada
Fax: 303-675-2176 or 800-344-3867 Toll Free USA/Canada
Email: orderlit@onsemi.com

N. American Technical Support: 800-282-9855 Toll Free
USA/Canada
Europe, Middle East and Africa Technical Support:
Phone: 421 33 790 2910
Japan Customer Focus Center
Phone: 81-3-5773-3850

ON Semiconductor Website: www.onsemi.com
Order Literature: <http://www.onsemi.com/orderlit>
For additional information, please contact your local Sales Representative