

Switching Power Supply Type SPD 60W DIN rail mounting

CARLO GAVAZZI



- Universal AC input full range
- Installation on DIN rail 7.5 or 15mm
- Short circuit protection
- Overload protection
- Class 2 output
- High efficiency
- LED indicator for DC power ON
- Power Ok output
- CE, TUV approved and cULus Listed

Product Description

The Switching power supplies and compact dimensions and performance are a must. designed to be used in all automation application where the installation is on a DIN rail

Ordering Key

SP D 24 60 1 B

Model _____
 Mounting (D = Din rail) _____
 Output voltage _____
 Output power _____
 Input Type _____
 Optional features _____

Input type: 1= single phase

Approvals



Optional Features

Description	Code
Spring connectors	B

Output Performances

Model	Rated output Voltage (VDC)	Output Power (W)	Output Current (A)	Voltage Trim Range		DC ON green LED at start up DC LOW red LED after start up		Typical Efficiency
				Min. VDC	Max. VDC	Min. VDC	Max. VDC	
SPD05	5	50	10.0	5	5.5	3.5	4.5	79%
SPD12	12	60	5.0	12	14	9.0	10.8	86%
SPD24	24	60	2.5	24	28	18	21.6	89%
SPD48	48	60	1.25	48	55	37	43	89%

Output Data

Line regulation	± 0.5%	Rated continuous loading	5V Model	10A @ 5VDC/9.0A @ 5.5VDC	
Load regulation	± 0.5%		12V Model	5A @ 12VDC/4.25A @ 14VDC	
Minimum load (A)	0	24V Model	2.5A @ 24VDC/2.1A @ 28VDC	Reverse voltage	
Turn on time (full resistive load)	1000ms max	48V Model	1.25A @ 48VDC/1.08A @ 55VDC		
Transient recovery time	2ms	Capacitor load	7000µF		
Ripple and noise	50mVpp		Voltage rise time at full resistive load	150ms max	
Output voltage accuracy	± 1%				
Temperature coefficient	± 0.03%/°C				
Hold up time	Vi= 115VAC 20ms Vi= 230VAC 30ms				
Voltage fall time (I _{0nom})	150ms max				

Input Data

Rated input voltage	100 - 240VAC		Power dissipation		
Voltage range			(Vi : 230VAC, lo nom)	5V Model	12.5W
AC	85 - 264VAC		12V Model	9.0W	
DC	90 - 375VDC		24V Model	8.8W	
Rated input current			48V Model	7.8W	
(Vi : 115VAC, lo nom) Typ.	1060mA		Frequency range	47- 63Hz	
Max.	1500mA		Leakage current		
Inrush current			Input-Output	0.25mA	
Vi= 115VAC	20A		Input-FG	3.5mA	
Vi= 230VAC	40A				

Controls and Protections

Overload	110 – 150%		Over voltage protection	VDC	
Input fuse	T2A/250VAC internal ¹⁾			Min.	Max.
Output short circuit	Fold forward		5V Model	6.0	6.8
Power ready output (Rdy)			12V Model	15	16.5
(only SPD 24) On threshold	Vout > 19,2V ± 2%		24V Model	30	33
Off threshold	Vout < 19,1V ± 2%		48V Model	60	66
			Internal surge voltage protection	Varistor	
			(IEC 61000-4-5)		

¹⁾ Fuse not replaceable by user

General Data (@ nominal line, full load, 25°C)

Ambient temperature	-40°C to 71°C		MTBF (Bellcore issue 6 @ 40°C, GB)		
Derating (>61°C to +71°C)	2.5%/°C		5V Model	498000 Hours	
Ambient humidity	20 ~ 95%RH		12V Model	504000 Hours	
Storage	-40°C to +85°C		24V Model	520000 Hours	
Protection degree	IP20		48V Model	531000 Hours	
Cooling	Free air convection		Case material	Plastic: PC, UL94-V0	
Insulation voltage			Pollution degree	2	
Input-Output	3.000VAC/4242VDC min		Altitude	2000m	
Input-FG	1.500VAC/2121VDC min		Dimensions LxWxD mm(inch)	90(3.60)x40.5(1.59)x114(4.49)	
Insulation resistance I/O	100MΩ min (@ 500VDC)		Weight	340g	

Norms and Standards

Vibration resistance	meet IEC 60068-2-6 (Mounting by rail: 10-500Hz, 2G, along X, Y, Z each Axis, 60 min for each Axis)	CE	EN 61000-6-3, EN 55022 Class B, EN 61000-3-2, EN 61000-3-3, EN 61000-6-2, EN 55024, EN 61000-4-2 Level 4, EN 61000-4-3 Level 3, EN 61000-4-4 Level 4, EN 61000-4-5 L-Level 3, L/N-FG Level 4, EN 61000-4-6 Level 3, EN 61000-4-8 Level 4, EN 61000-4-11, ENV 50204 Level 2, EN 61204-3
Shock resistance	meet IEC 60068-2-27 (15G, 11ms, 3 Axis, 6 faces, 3 times for each face)		
UL / cUL	UL508 listed, UL60950-1, UL1310 Class 2 Power (only 5V, 12V w/o Class 2) Recognized, ISA 12.12.01 (Class 1, Division 2, Groups A, B, C and D)		
TUV	EN 60950-1, CB scheme EN 61558-1, EN 61558-2-17 (meet EN 60204)		
CCC	GB4943, GB9254, GB17625.1		

Block Diagrams

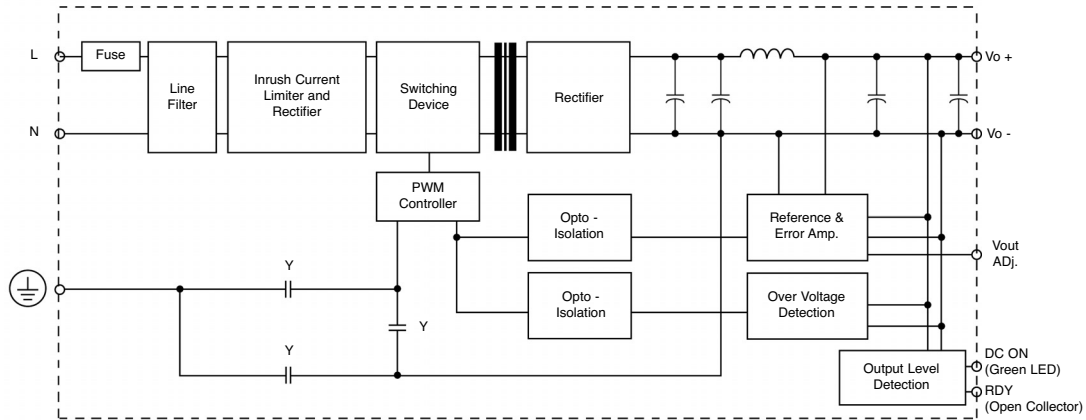

Pin Assignment and Front Controls

Pin No.	Designation	Description
1	RDY	DC OK, output for relay (only on SPD 24)
2	+	Positive output terminal
3	+	Positive output terminal
4	-	Negative output terminal
5	-	Negative output terminal
6	GND	Ground terminal to minimise High frequency emissions
7	L	Phase input (no polarity with DC input)
8	N	Neutral input (no polarity with DC input)
Pot1	Vout ADJ.	Trimmer for fine output voltage adjustment
L1	DC ON	DC output ready LED

Output Rdy Wiring Diagram

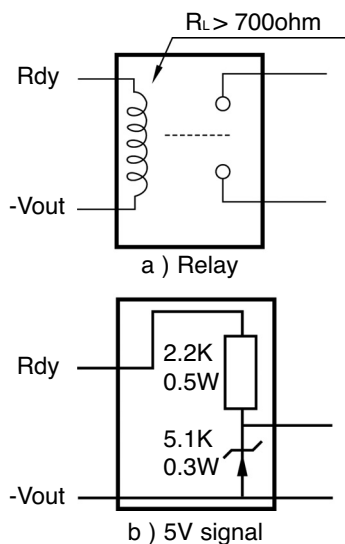

Derating Diagram

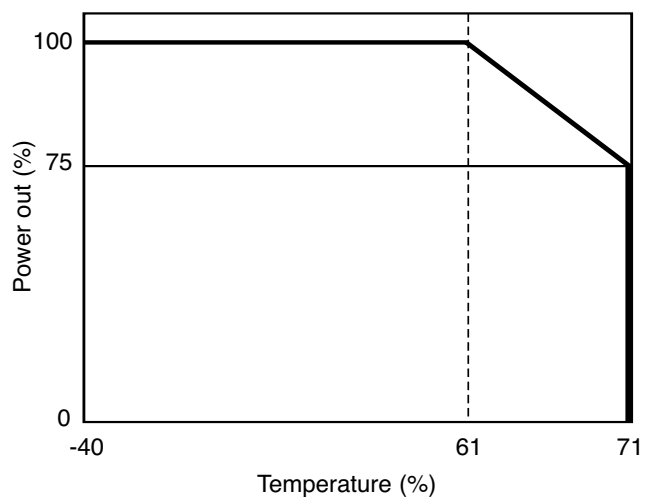

Typ. Current Limited Curve

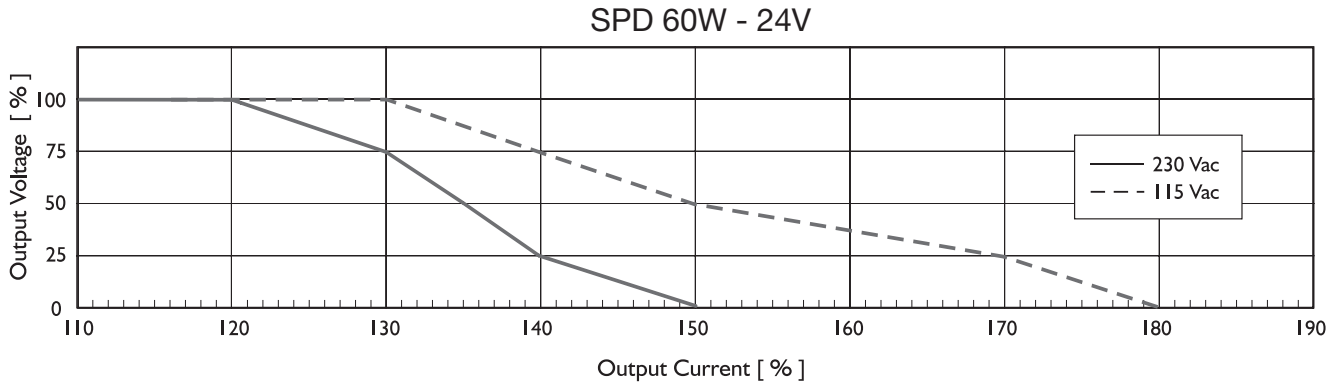

Mechanical Drawings mm (inches)

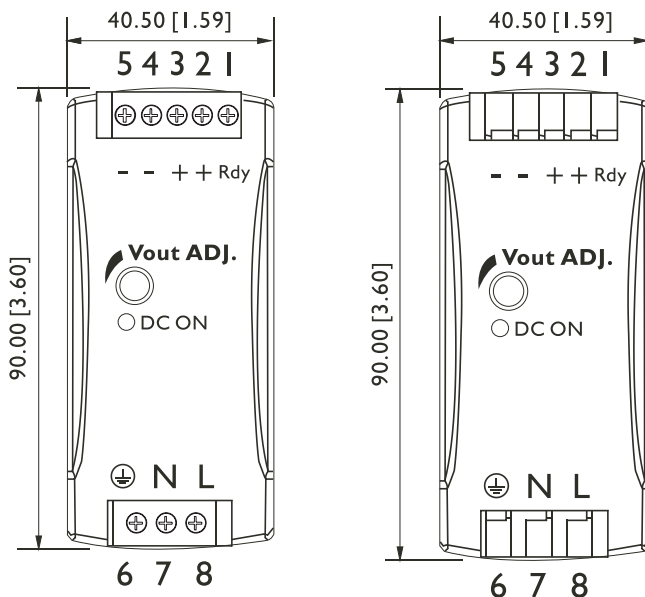

Typ. Efficiency Curve

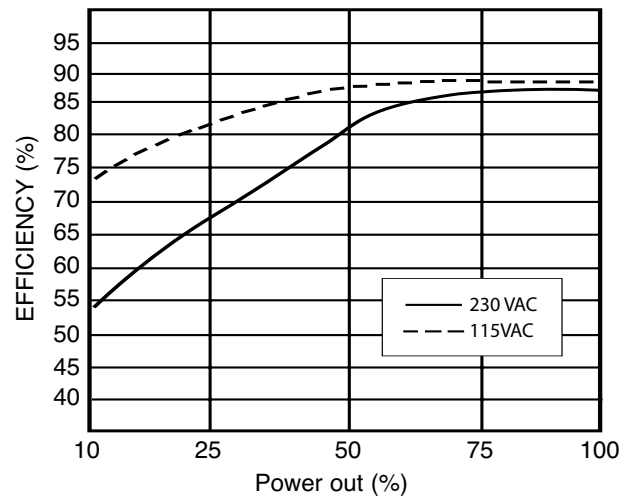

Installation

Ventilation and cooling	Normal convection All sides 25mm free space for cooling is recommended
Connector size range	AWG24-14 (0.2~2mm ²) flexible/solid cable, 10mm stripping at cable and recommends use copper conductors only, 60/75°C
Spring terminal	
Screw terminal	AWG26-12 (0.2~2.5mm ²) flexible/solid cable, connector can withstand torque at max 0,56Nm (5 lbs-in). 4~5 mm stripping at cable and recommends use copper conductors only, 60/75°C
Max. torque for terminal	
Input terminals	0.56Nm (5.0lb-in)
Output terminals	0.56Nm (5.0lb-in)
General tolerances mm(in.)	
0.00 (0.00) ÷ 30.00 (1.18)	±0.30 (0.01)
30.00 (1.18) ÷ 120.00 (4.72)	±0.50 (0.02)