

32 MHz 32-bit RX MCUs, 50 DMIPS, up to 512 Kbytes of flash memory,
USB 2.0 full-speed host/function/OTG, up to 6 comms channels,
12-bit A/D, 8-bit D/A, RTC

Features

■ 32-bit RX CPU core

- 32 MHz maximum operating frequency
Capable of 50 DMIPS when operating at 32 MHz
- Accumulator handles 64-bit results (for a single instruction) from 32-bit × 32-bit operations
- Multiplication and division unit handles 32-bit × 32-bit operations (multiplication instructions take one CPU clock cycle)
- Fast interrupt
- CISC Harvard architecture with five-stage pipeline
- Variable-length instruction format, ultra-compact code
- On-chip debugging circuit

■ Low power consumption functions

- Operation from a single 1.8 to 3.6 V supply
- Three low power consumption modes
- Supply current
High-speed operating mode: 0.11 mA/MHz
Software standby mode: 0.44 μA
- Recovery time from software standby mode: 4.8 μs

■ On-chip flash memory for code, no wait states

- Operation at 32 MHz, read cycle of 31.25 ns
- No wait states for reading at full CPU speed
- 16 to 512 Kbyte capacities
- Programmable at 1.8 V
- For instructions and operands

■ On-chip data flash memory

- 8 Kbytes
1,000,000 Erase/Write cycles (typ.)
- BGO (Background Operation)

■ On-chip SRAM, no wait states

- 8 to 64 Kbyte capacities

■ Data transfer controller (DTC)

- Four transfer modes
- Transfer can be set for each interrupt source.

■ Event link controller (ELC)

- Module operation can be initiated by event signals without going through interrupts.
- Link operation between modules is possible while the CPU is sleeping.

■ Reset and power supply voltage management

- Six types including Power-On Reset (POR)
- Low voltage detection (LVD) with voltage settings

■ Clock functions

- External clock input frequency: Up to 20 MHz
- Main clock oscillator frequency: 1 to 20 MHz
- Sub-clock oscillator frequency: 32.768 kHz
- PLL circuit input: 4 to 8 MHz
- Low-speed on-chip oscillator: 4 MHz
- High-speed on-chip oscillator: 32 MHz±1% (-20 to 85°C)
- IWDT-dedicated on-chip oscillator: 15 kHz
- Generate a dedicated 32.768-kHz clock for the RTC
- On-chip clock frequency accuracy measurement circuit (CAC)

■ Realtime clock (RTC)

- 30-second, leap year, and error adjustment functions
- Calendar count mode or binary count mode selectable
- Capable of initiating exit from software standby mode

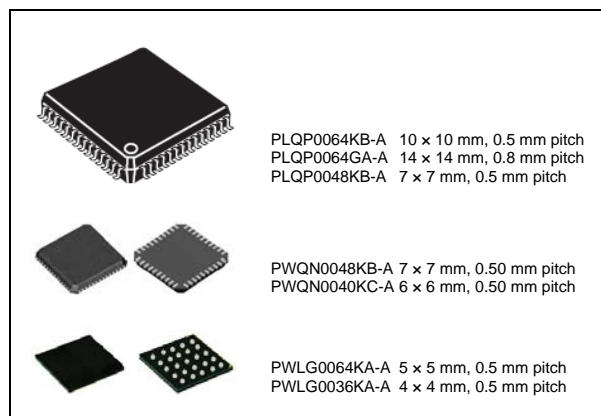

■ Independent watchdog timer (IWDT)

- 15-kHz on-chip oscillator produces a dedicated clock signal to drive IWDT operation.

■ On-chip functions for IEC 60730 compliance

- Clock frequency accuracy measurement circuit, IWDT, functions to assist in RAM testing, etc.

■ Up to six channels for communication

- USB: USB 2.0 host (32 Kbyte or more ROM)/function/On-The-Go (OTG) (one channel), full-speed = 12 Mbps, low-speed = 1.5 Mbps, isochronous transfer, and BC (Battery Charger) supported
- SCI: Asynchronous mode, clock synchronous mode, smart card interface (up to three channels)
- I²C bus interface: Transfer at up to 400 kbps, capable of SMBus operation (one channel)
- RSPI: Up to 16 Mbps (one channel)

■ Up to 8 extended-function timers

- 16-bit MTU: Input capture/output compare, complementary PWM output, phase counting mode (six channels)
- 16-bit CMT (two channels)

■ 12-bit A/D converter

- Up to 14 channels
- 1.0 μs minimum conversion speed
- Double trigger (data duplication) function for motor control

■ 8-bit D/A converter

- Two channels (for 64 pins only)

■ Temperature sensor

■ General I/O ports

- 5-V tolerant, open drain, input pull-up

■ Multi-function pin controller (MPC)

- Multiple I/O pins can be selected for peripheral functions.

■ Unique ID

- 32-byte ID code for the MCU

■ Operating temperature range

- -40 to +85°C
- -40 to +105°C

1. Overview

1.1 Outline of Specifications

Table 1.1 lists the specifications, and Table 1.2 gives a comparison of the functions of the products in different packages.

Table 1.1 is for products with the greatest number of functions, so the number of peripheral modules and channels will differ in accordance with the package type. For details, see Table 1.2, Comparison of Functions for Different Packages.

Table 1.1 Outline of Specifications (1/3)

Classification	Module/Function	Description
CPU	CPU	<ul style="list-style-type: none"> Maximum operating frequency: 32 MHz 32-bit RX CPU Minimum instruction execution time: One instruction per clock cycle Address space: 4-Gbyte linear Register set <ul style="list-style-type: none"> General purpose: Sixteen 32-bit registers Control: Eight 32-bit registers Accumulator: One 64-bit register Basic instructions: 73 DSP instructions: 9 Addressing modes: 10 Data arrangement <ul style="list-style-type: none"> Instructions: Little endian Data: Selectable as little endian or big endian On-chip 32-bit multiplier: 32-bit × 32-bit → 64-bit On-chip divider: 32-bit ÷ 32-bit → 32 bits Barrel shifter: 32 bits
Memory	ROM	<ul style="list-style-type: none"> Capacity: 16 K /32 K /64 K /96 K /128 K /256 K /384 K /512 Kbytes 32 MHz, no-wait memory access Programming/erasing method: <ul style="list-style-type: none"> Serial programming (asynchronous serial communication/USB communication), self-programming
	RAM	<ul style="list-style-type: none"> Capacity: 8 K /10 K /16 K /32 K /64 Kbytes 32 MHz, no-wait memory access
	E2 DataFlash	<ul style="list-style-type: none"> Capacity: 8 Kbytes Number of erase/write cycles: 1,000,000 (typ)
MCU operating mode		Single-chip mode
Clock	Clock generation circuit	<ul style="list-style-type: none"> Main clock oscillator, sub-clock oscillator, low-speed on-chip oscillator, high-speed on-chip oscillator, PLL frequency synthesizer, and IWDT-dedicated on-chip oscillator Oscillation stop detection: Available Clock frequency accuracy measurement circuit (CAC) Independent settings for the system clock (ICLK), peripheral module clock (PCLK), and FlashIF clock (FCLK) <ul style="list-style-type: none"> The CPU and system sections such as other bus masters run in synchronization with the system clock (ICLK): 32 MHz (at max.) Peripheral modules run in synchronization with the PCLK: 32 MHz (at max.) The flash peripheral circuit runs in synchronization with the FCLK: 32 MHz (at max.) The ICLK frequency can only be set to FCLK, PCLKB, or PCLKD multiplied by n (n: 1, 2, 4, 8, 16, 32, 64).
Resets		RES# pin reset, power-on reset, voltage monitoring reset, independent watchdog timer reset, and software reset
Voltage detection	Voltage detection circuit (LVDAa)	<ul style="list-style-type: none"> When the voltage on VCC falls below the voltage detection level, an internal reset or internal interrupt is generated. Voltage detection circuit 1 is capable of selecting the detection voltage from 10 levels Voltage detection circuit 2 is capable of selecting the detection voltage from 4 levels
Low power consumption	Low power consumption functions	<ul style="list-style-type: none"> Module stop function Three low power consumption modes <ul style="list-style-type: none"> Sleep mode, deep sleep mode, and software standby mode
	Function for lower operating power consumption	<ul style="list-style-type: none"> Operating power control modes <ul style="list-style-type: none"> High-speed operating mode, middle-speed operating mode, and low-speed operating mode
Interrupt	Interrupt controller (ICUb)	<ul style="list-style-type: none"> Interrupt vectors: 82 External interrupts: 9 (NMI, IRQ0 to IRQ7 pins) Non-maskable interrupts: 4 (NMI pin, voltage monitoring 1 interrupt, voltage monitoring 2 interrupt, and IWDT interrupt) 16 levels specifiable for the order of priority

Table 1.1 Outline of Specifications (2/3)

Classification	Module/Function	Description
DMA	Data transfer controller (DTCa)	<ul style="list-style-type: none"> Transfer modes: Normal transfer, repeat transfer, and block transfer Activation sources: Interrupts Chain transfer function
I/O ports	General I/O ports	64-pin /48-pin /40-pin /36-pin <ul style="list-style-type: none"> I/O: 46/30/24/20 Input: 2/2/1/1 Pull-up resistors: 38/24/19/16 Open-drain outputs: 34/24/19/16 5-V tolerance: 4/4/4/4
	Event link controller (ELC)	<ul style="list-style-type: none"> Event signals of 35 types can be directly connected to the module Operations of timer modules are selectable at event input Capable of event link operation for port B
	Multi-function pin controller (MPC)	Capable of selecting the input/output function from multiple pins
Timers	Multi-function timer pulse unit 2 (MTU2a)	<ul style="list-style-type: none"> (16 bits × 6 channels) × 1 unit Time bases for the six 16-bit timer channels can be provided via up to 16 pulse-input/output lines and three pulse-input lines Select from among eight or seven counter-input clock signals for each channel (PCLK/1, PCLK/4, PCLK/16, PCLK/64, PCLK/256, PCLK/1024, MTCLKA, MTCLKB, MTCLKC, MTCLKD) other than channel 5, for which only four signals are available. Input capture function 21 output compare/input capture registers Pulse output mode Complementary PWM output mode Reset-synchronized PWM mode Phase counting mode Capable of generating conversion start triggers for the A/D converter
	Port output enable 2 (POE2a)	Controls the high-impedance state of the MTU's waveform output pins
	Compare match timer (CMT)	<ul style="list-style-type: none"> (16 bits × 2 channels) × 1 unit Select from among four clock signals (PCLK/8, PCLK/32, PCLK/128, PCLK/512)
	Independent watchdog timer (IWDTa)	<ul style="list-style-type: none"> 14 bits × 1 channel Count clock: Dedicated low-speed on-chip oscillator for the IWDT Frequency divided by 1, 16, 32, 64, 128, or 256
	Realtime clock (RTCA)	<ul style="list-style-type: none"> Clock source: Sub-clock Calendar count mode or binary count mode selectable Interrupts: Alarm interrupt, periodic interrupt, and carry interrupt
Communication functions	Serial communications interfaces (SC1e, SC1f)	<ul style="list-style-type: none"> 3 channels (channel 1, 5: SC1e, channel 12: SC1f) Serial communications modes: Asynchronous, clock synchronous, and smart card interface On-chip baud rate generator allows selection of the desired bit rate Choice of LSB first or MSB first transfer Average transfer rate clock can be input from MTU2 timers Simple I²C Simple SPI Master/slave mode supported (SC1f only) Start frame and information frame are included (SC1f only) Start-bit detection in asynchronous mode: Low level or falling edge is selectable
	I ² C bus interface (RIIC)	<ul style="list-style-type: none"> 1 channel Communications formats: I²C bus format/SMBus format Master mode or slave mode selectable Supports fast mode
	Serial peripheral interface (RSPI)	<ul style="list-style-type: none"> 1 channel Transfer facility Using the MOSI (master out, slave in), MISO (master in, slave out), SSL (slave select), and RSPI clock (RSPCK) signals enables serial transfer through SPI operation (four lines) or clock-synchronous operation (three lines) Capable of handling serial transfer as a master or slave Data formats Choice of LSB first or MSB first transfer The number of bits in each transfer can be changed to 8, 9, 10, 11, 12, 13, 14, 15, 16, 20, 24, or 32 bits. 128-bit buffers for transmission and reception Up to four frames can be transmitted or received in a single transfer operation (with each frame having up to 32 bits) Double buffers for both transmission and reception

Table 1.1 Outline of Specifications (3/3)

Classification	Module/Function	Description
Communication function	USB 2.0 host/function module (USBc)	<ul style="list-style-type: none"> • USB Device Controller (UDC) and transceiver for USB 2.0 are incorporated. • Host (32-Kbyte or more ROM)/function module: 1 port • Compliant with USB version 2.0 • Transfer speed: Full-speed (12 Mbps), low-speed (1.5 Mbps) • OTG (On-The-Go) is supported. • Isochronous transfer is supported. • BC (Battery Charger) is supported.
12-bit A/D converter (S12ADb)		<ul style="list-style-type: none"> • 1 unit (1 unit × 14 channels) • 12-bit resolution • Minimum conversion time: 1.0 μs per channel when the ADCLK is operating at 32 MHz • Operating modes <ul style="list-style-type: none"> • Scan mode (single scan mode, continuous scan mode, and group scan mode) • Double trigger mode (duplication of A/D conversion data) • A/D conversion start conditions <ul style="list-style-type: none"> • A software trigger, a trigger from a timer (MTU), an external trigger signal, or ELC
Temperature sensor (TEMPSA)		<ul style="list-style-type: none"> • 1 channel • The voltage of the temperature is converted into a digital value by the 12-bit A/D converter.
D/A converter (DA)		<ul style="list-style-type: none"> • 2 channels • 8-bit resolution • Output voltage: 0 V to VCC
CRC calculator (CRC)		<ul style="list-style-type: none"> • CRC code generation for arbitrary amounts of data in 8-bit units • Select any of three generating polynomials: <ul style="list-style-type: none"> • $X^8 + X^2 + X + 1$, $X^{16} + X^{15} + X^2 + 1$, or $X^{16} + X^{12} + X^5 + 1$ • Generation of CRC codes for use with LSB first or MSB first communications is selectable.
Data operation circuit (DOC)		Comparison, addition, and subtraction of 16-bit data
Unique ID		32-byte ID code for the MCU
Power supply voltages/Operating frequencies		VCC = 1.8 to 2.4 V: 8 MHz, VCC = 2.4 to 2.7 V: 16 MHz, VCC = 2.7 to 3.6 V: 32 MHz
Supply current		3.2 mA at 32 MHz (typ.)
Operating temperature range		D version: -40 to +85°C, G version: -40 to +105°C
Packages		64-pin LQFP (PLQP0064KB-A) 10 × 10 mm, 0.5 mm pitch 64-pin LQFP (PLQP0064GA-A) 14 × 14 mm, 0.8 mm pitch 64-pin WFLGA (PWLG0064KA-A) 5 × 5 mm, 0.5 mm pitch 48-pin LQFP (PLQP0048KB-A) 7 × 7 mm, 0.5 mm pitch 48-pin HWQFN (PWQN0048KB-A) 7 × 7 mm, 0.5 mm pitch 40-pin HWQFN (PWQN0040KC-A) 6 × 6 mm, 0.50 mm pitch 36-pin WFLGA (PWLG0036KA-A) 4 × 4 mm, 0.5 mm pitch
On-chip debugging system		E1 emulator (FINE interface)

Table 1.2 Comparison of Functions for Different Packages

Module/Functions		RX111 Group			
		64 Pins	48 Pins	40 Pins	36 Pins
Interrupts	External interrupts	NMI, IRQ0 to IRQ7			
DMA	Data transfer controller	Supported			
Timers	Multi-function timer pulse unit 2	6 channels (MTU0 to MTU5)			
	Port output enable 2	POE0# to POE3#, POE8#		POE0#, POE2#, POE3#, POE8#	
	Compare match timer	2 channels x 1 unit			
	Realtime clock	Supported		Not supported	
	Independent watchdog timer	Supported			
Communication functions	Serial communications interfaces [simple I ² C, simple SPI]	2 channels (SCI1, SCI5)			
	Serial communications interface [simple I ² C, simple SPI]	1 channel (SCI12)			
	I ² C bus interface	1 channel			
	Serial peripheral interface	1 channel	1 channel (SSLA1 and SSLA3 are not supported)		1 channel (SSLA1 to SSLA3 are not supported)
	USB 2.0 host/function module (USBc)	1 channel (Host/Function/ OTG)	1 channel (Host/Function)		
12-bit A/D converter (including high-precision channels)		14 channels (6 channels)	10 channels (4 channels)	8 channels (3 channels)	7 channels (2 channels)
D/A converter		2 channels	Not supported		
Temperature sensor		Supported			
CRC calculator		Supported			
Event link controller		Supported			
Packages		64-pin LQFP 64-pin LQFP 64-pin WFLGA	48-pin LQFP 48-pin HWQFN	40-pin HWQFN	36-pin WFLGA

1.2 List of Products

Table 1.3 is a list of products, and Figure 1.1 shows how to read the product part no., memory capacity, and package type.

Table 1.3 List of Products (1/2)

Group	Part No.	Orderable Part No.	Package	ROM Capacity	RAM Capacity	E2 DataFlash	Maximum Operating Frequency	Operating Temperature
RX111	R5F51118AGFM	R5F51118AGFM#3A	PLQP0064KB-A	512 Kbytes	64 Kbytes	8 Kbytes	32 MHz	-40 to +105°C
	R5F51118AGFK	R5F51118AGFK#3A	PLQP0064GA-A					
	R5F51118AGFL	R5F51118AGFL#3A	PLQP0048KB-A					
	R5F51118AGNE	R5F51118AGNE#UA	PWQN0048KB-A					
	R5F51117AGFM	R5F51117AGFM#3A	PLQP0064KB-A	384 Kbytes				
	R5F51117AGFK	R5F51117AGFK#3A	PLQP0064GA-A					
	R5F51117AGFL	R5F51117AGFL#3A	PLQP0048KB-A					
	R5F51117AGNE	R5F51117AGNE#UA	PWQN0048KB-A					
	R5F51116AGFM	R5F51116AGFM#3A	PLQP0064KB-A	256 Kbytes	32 Kbytes			
	R5F51116AGFK	R5F51116AGFK#3A	PLQP0064GA-A					
	R5F51116AGFL	R5F51116AGFL#3A	PLQP0048KB-A					
	R5F51116AGNE	R5F51116AGNE#UA	PWQN0048KB-A					
	R5F51115AGFM	R5F51115AGFM#3A	PLQP0064KB-A	128 Kbytes	16 Kbytes			
	R5F51115AGFK	R5F51115AGFK#3A	PLQP0064GA-A					
	R5F51115AGFL	R5F51115AGFL#3A	PLQP0048KB-A					
	R5F51115AGNE	R5F51115AGNE#UA	PWQN0048KB-A					
	R5F51114AGFM	R5F51114AGFM#3A	PLQP0064KB-A	96 Kbytes				
	R5F51114AGFK	R5F51114AGFK#3A	PLQP0064GA-A					
	R5F51114AGFL	R5F51114AGFL#3A	PLQP0048KB-A					
	R5F51114AGNE	R5F51114AGNE#UA	PWQN0048KB-A					
	R5F51113AGFM	R5F51113AGFM#3A	PLQP0064KB-A	64 Kbytes	10 Kbytes			
	R5F51113AGFK	R5F51113AGFK#3A	PLQP0064GA-A					
	R5F51113AGFL	R5F51113AGFL#3A	PLQP0048KB-A					
	R5F51113AGNE	R5F51113AGNE#UA	PWQN0048KB-A					
	R5F51113AGNF	R5F51113AGNF#UA	PWQN0040KC-A					
	R5F51111AGFM	R5F51111AGFM#3A	PLQP0064KB-A	32 Kbytes				
	R5F51111AGFK	R5F51111AGFK#3A	PLQP0064GA-A					
	R5F51111AGFL	R5F51111AGFL#3A	PLQP0048KB-A					
R5F51111AGNE	R5F51111AGNE#UA	PWQN0048KB-A						
R5F51111AGNF	R5F51111AGNF#UA	PWQN0040KC-A						
R5F5111JAGFM	R5F5111JAGFM#3A	PLQP0064KB-A	16 Kbytes	8 Kbytes				
R5F5111JAGFK	R5F5111JAGFK#3A	PLQP0064GA-A						
R5F5111JAGFL	R5F5111JAGFL#3A	PLQP0048KB-A						
R5F5111JAGNE	R5F5111JAGNE#UA	PWQN0048KB-A						
R5F5111JAGNF	R5F5111JAGNF#UA	PWQN0040KC-A						

Table 1.3 List of Products (2/2)

Group	Part No.	Orderable Part No.	Package	ROM Capacity	RAM Capacity	E2 DataFlash	Maximum Operating Frequency	Operating Temperature
RX111	R5F51118ADFM	R5F51118ADFM#3A	PLQP0064KB-A	512 Kbytes	64 Kbytes	8 Kbytes	32 MHz	-40 to +85°C
	R5F51118ADFK	R5F51118ADFK#3A	PLQP0064GA-A					
	R5F51118ADLF	R5F51118ADLF#UA	PWLG0064KA-A					
	R5F51118ADFL	R5F51118ADFL#3A	PLQP0048KB-A					
	R5F51118ADNE	R5F51118ADNE#UA	PWQN0048KB-A					
	R5F51117ADFM	R5F51117ADFM#3A	PLQP0064KB-A	384 Kbytes				
	R5F51117ADFK	R5F51117ADFK#3A	PLQP0064GA-A					
	R5F51117ADLF	R5F51117ADLF#UA	PWLG0064KA-A					
	R5F51117ADFL	R5F51117ADFL#3A	PLQP0048KB-A					
	R5F51117ADNE	R5F51117ADNE#UA	PWQN0048KB-A					
	R5F51116ADFM	R5F51116ADFM#3A	PLQP0064KB-A	256 Kbytes	32 Kbytes			
	R5F51116ADFK	R5F51116ADFK#3A	PLQP0064GA-A					
	R5F51116ADLF	R5F51116ADLF#UA	PWLG0064KA-A					
	R5F51116ADFL	R5F51116ADFL#3A	PLQP0048KB-A					
	R5F51116ADNE	R5F51116ADNE#UA	PWQN0048KB-A					
	R5F51115ADFM	R5F51115ADFM#3A	PLQP0064KB-A	128 Kbytes	16 Kbytes			
	R5F51115ADFK	R5F51115ADFK#3A	PLQP0064GA-A					
	R5F51115ADLF	R5F51115ADLF#UA	PWLG0064KA-A					
	R5F51115ADFL	R5F51115ADFL#3A	PLQP0048KB-A					
	R5F51115ADNE	R5F51115ADNE#UA	PWQN0048KA-A					
	R5F51114ADFM	R5F51114ADFM#3A	PLQP0064KB-A	96 Kbytes				
	R5F51114ADFK	R5F51114ADFK#3A	PLQP0064GA-A					
	R5F51114ADLF	R5F51114ADLF#UA	PWLG0064KA-A					
	R5F51114ADFL	R5F51114ADFL#3A	PLQP0048KB-A					
	R5F51114ADNE	R5F51114ADNE#UA	PWQN0048KB-A					
	R5F51113ADFM	R5F51113ADFM#3A	PLQP0064KB-A	64 Kbytes	10 Kbytes			
	R5F51113ADFK	R5F51113ADFK#3A	PLQP0064GA-A					
	R5F51113ADLF	R5F51113ADLF#UA	PWLG0064KA-A					
	R5F51113ADFL	R5F51113ADFL#3A	PLQP0048KB-A					
	R5F51113ADNE	R5F51113ADNE#UA	PWQN0048KB-A					
	R5F51113ADLM	R5F51113ADLM#UA	PWLG0036KA-A					
	R5F51113ADNF	R5F51113ADNF#UA	PWQN0040KC-A					
R5F51111ADFM	R5F51111ADFM#3A	PLQP0064KB-A	32 Kbytes					
R5F51111ADFK	R5F51111ADFK#3A	PLQP0064GA-A						
R5F51111ADLF	R5F51111ADLF#UA	PWLG0064KA-A						
R5F51111ADFL	R5F51111ADFL#3A	PLQP0048KB-A						
R5F51111ADNE	R5F51111ADNE#UA	PWQN0048KB-A						
R5F51111ADLM	R5F51111ADLM#UA	PWLG0036KA-A						
R5F51111ADNF	R5F51111ADNF#UA	PWQN0040KC-A						
R5F5111JADFM	R5F5111JADFM#3A	PLQP0064KB-A	16 Kbytes	8 Kbytes				
R5F5111JADFK	R5F5111JADFK#3A	PLQP0064GA-A						
R5F5111JADLF	R5F5111JADLF#UA	PWLG0064KA-A						
R5F5111JADFL	R5F5111JADFL#3A	PLQP0048KB-A						
R5F5111JADNE	R5F5111JADNE#UA	PWQN0048KB-A						
R5F5111JADLM	R5F5111JADLM#UA	PWLG0036KA-A						
R5F5111JADNF	R5F5111JADNF#UA	PWQN0040KC-A						

Note: • Orderable part numbers are current as of when this manual was published. Please make sure to refer to the relevant product page on the Renesas website for the latest part numbers.

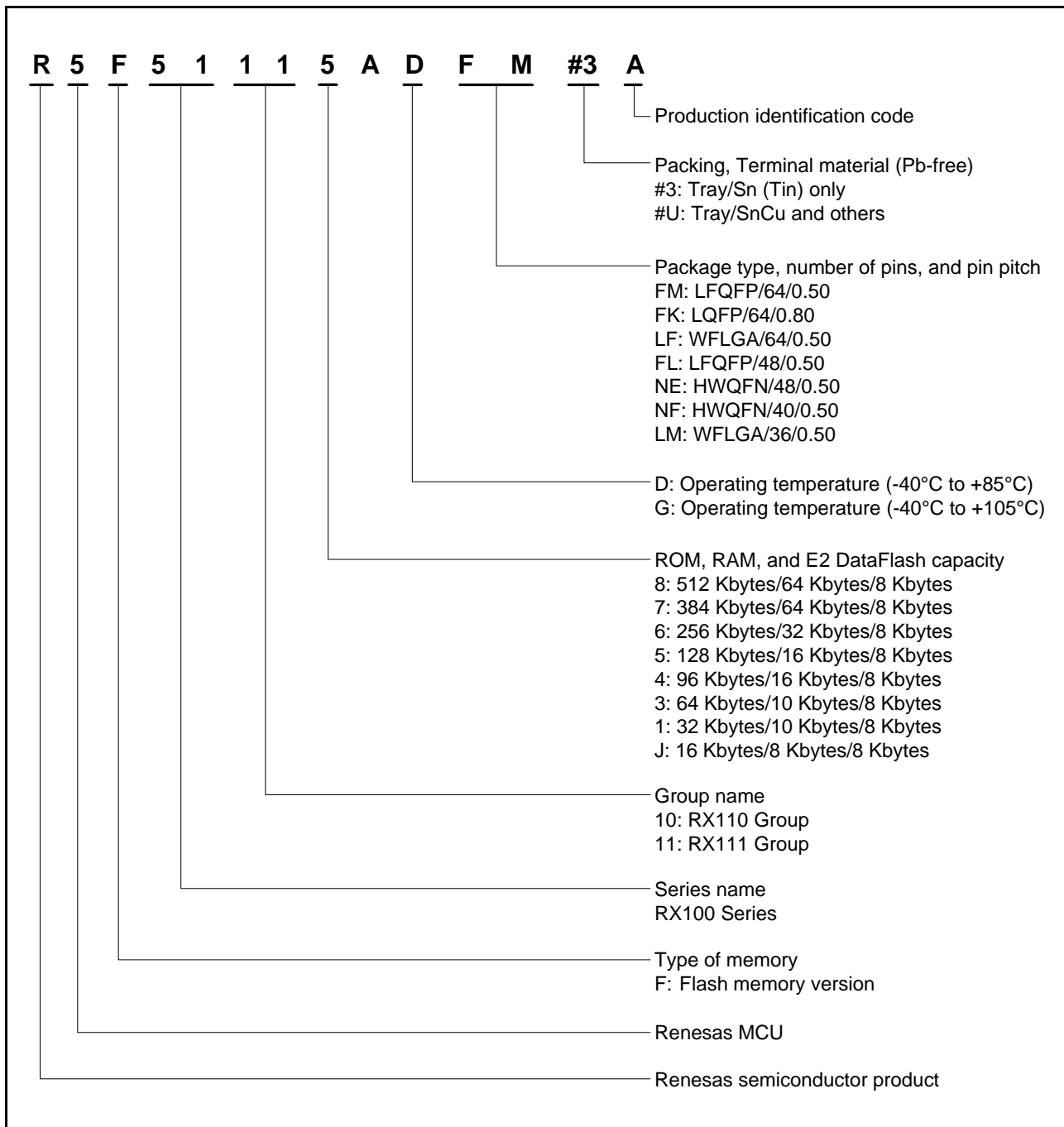

Figure 1.1 How to Read the Product Part No., Memory Capacity, and Package Type

1.3 Block Diagram

Figure 1.2 shows a block diagram.

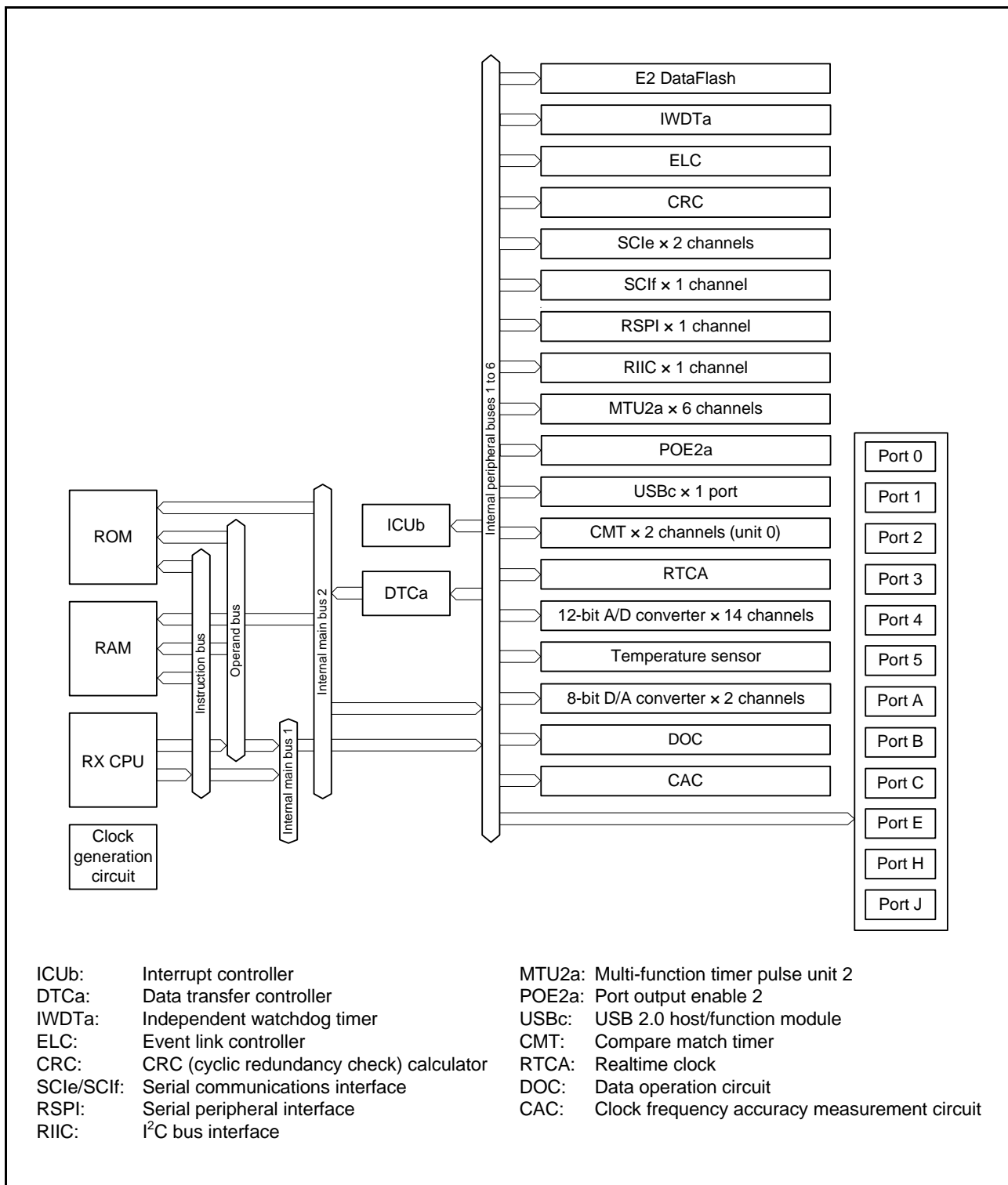

Figure 1.2 Block Diagram

1.4 Pin Functions

Table 1.4 lists the pin functions.

Table 1.4 Pin Functions (1/3)

Classifications	Pin Name	I/O	Description
Power supply	VCC	Input	Power supply pin. Connect it to the system power supply.
	VCL	—	Connect this pin to the VSS pin via the 4.7 μ F smoothing capacitor used to stabilize the internal power supply. Place the capacitor close to the pin.
	VSS	Input	Ground pin. Connect it to the system power supply (0 V).
	VCC_USB	Input	Power supply pin for USB. Connect this pin to VCC.
	VSS_USB	Input	Ground pin for USB. Connect this pin to VSS.
Analog power supply	AVCC0	Input	Analog voltage supply pin for the 12-bit A/D converter. Connect this pin to VCC when not using the 12-bit A/D converter.
	AVSS0	Input	Analog ground pin for the 12-bit A/D converter. Connect this pin to VSS when not using the 12-bit A/D converter.
	VREFH0	Input	Analog reference voltage supply pin for the 12-bit A/D converter. Connect this pin to VCC when not using the 12-bit A/D converter.
	VREFL0	Input	Analog reference ground pin for the 12-bit A/D converter. Connect this pin to VSS when not using the 12-bit A/D converter.
Clock	XTAL	Output/ Input *1	Pins for connecting a crystal. An external clock can be input through the XTAL pin.
	EXTAL	Input	
	XCIN	Input	Input/output pins for the sub-clock oscillator. Connect a crystal between XCIN and XCOU.
	XCOU	Output	
	CLKOUT	Output	Clock output pin.
Operating mode control	MD	Input	Pin for setting the operating mode. The signal levels on this pin must not be changed during operation.
	UB#	Input	Pin used for boot mode (USB interface).
	UPSEL	Input	Pin used for boot mode (USB interface).
System control	RES#	Input	Reset pin. This MCU enters the reset state when this signal goes low.
CAC	CACREF	Input	Input pin for the clock frequency accuracy measurement circuit.
On-chip emulator	FINED	I/O	FINE interface pin.
LVD	CMPA2	Input	Detection target voltage pin for voltage detection 2
Interrupts	NMI	Input	Non-maskable interrupt request pin.
	IRQ0 to IRQ7	Input	Interrupt request pins.
Multi-function timer pulse unit 2	MTIOC0A, MTIOC0B MTIOC0C, MTIOC0D	I/O	The TGRA0 to TGRD0 input capture input/output compare output/PWM output pins.
	MTIOC1A, MTIOC1B	I/O	The TGRA1 and TGRB1 input capture input/output compare output/PWM output pins.
	MTIOC2A, MTIOC2B	I/O	The TGRA2 and TGRB2 input capture input/output compare output/PWM output pins.
	MTIOC3A, MTIOC3B MTIOC3C, MTIOC3D	I/O	The TGRA3 to TGRD3 input capture input/output compare output/PWM output pins.
	MTIOC4A, MTIOC4B MTIOC4C, MTIOC4D	I/O	The TGRA4 to TGRD4 input capture input/output compare output/PWM output pins.
	MTIC5U, MTIC5V, MTIC5W	Input	The TGRU5, TGRV5, and TGRW5 input capture input/external pulse input pins.
	MTCLKA, MTCLKB, MTCLKC, MTCLKD	Input	Input pins for the external clock.
Port output enable 2	POE0# to POE3#, POE8#	Input	Input pins for request signals to place the MTU pins in the high impedance state.

Table 1.4 Pin Functions (2/3)

Classifications	Pin Name	I/O	Description	
Realtime clock	RTCOUT	Output	Output pin for the 1-Hz/64-Hz clock.	
Serial communications interface (SC1e)	• Asynchronous mode/clock synchronous mode			
	SCK1, SCK5	I/O	Input/output pins for the clock.	
	RXD1, RXD5	Input	Input pins for received data.	
	TXD1, TXD5	Output	Output pins for transmitted data.	
	CTS1#, CTS5#	Input	Input pins for controlling the start of transmission and reception.	
	RTS1#, RTS5#	Output	Output pins for controlling the start of transmission and reception.	
Serial communications interface (SC1e)	• Simple I ² C mode			
	SSCL1, SSCL5	I/O	Input/output pins for the I ² C clock.	
	SSDA1, SSDA5	I/O	Input/output pins for the I ² C data.	
	• Simple SPI mode			
	SCK1, SCK5	I/O	Input/output pins for the clock.	
	SMISO1, SMISO5	I/O	Input/output pins for slave transmit data.	
	SMOSI1, SMOSI5	I/O	Input/output pins for master transmit data.	
	SS1#, SS5#	Input	Chip-select input pins.	
Serial communications interface (SC1f)	• Asynchronous mode/clock synchronous mode			
	SCK12	I/O	Input/output pin for the clock.	
	RXD12	Input	Input pin for receiving data.	
	TXD12	Output	Output pin for transmitting data.	
	CTS12#	Input	Input pin for controlling the start of transmission and reception.	
	RTS12#	Output	Output pin for controlling the start of transmission and reception.	
	• Simple I ² C mode			
	SSCL12	I/O	Input/output pin for the I ² C clock.	
	SSDA12	I/O	Input/output pin for the I ² C data.	
	• Simple SPI mode			
	SCK12	I/O	Input/output pin for the clock.	
	SMISO12	I/O	Input/output pin for slave transmit data.	
	SMOSI12	I/O	Input/output pin for master transmit data.	
	SS12#	Input	Chip-select input pin.	
	• Extended serial mode			
	RXDX12	Input	Input pin for data reception by SC1f.	
	TXDX12	Output	Output pin for data transmission by SC1f.	
	SIOX12	I/O	Input/output pin for data reception or transmission by SC1f.	
	I ² C bus interface	SCL0	I/O	Input/output pin for I ² C bus interface clocks. Bus can be directly driven by the N-channel open drain output.
		SDA0	I/O	Input/output pin for I ² C bus interface data. Bus can be directly driven by the N-channel open drain output.
Serial peripheral interface	RSPCKA	I/O	Input/output pin for the RSPI clock.	
	MOSIA	I/O	Input/output pin for transmitting data from the RSPI master.	
	MISOA	I/O	Input/output pin for transmitting data from the RSPI slave.	
	SSLA0	I/O	Input/output pin to select the slave for the RSPI.	
	SSLA1 to SSLA3	Output	Output pins to select the slave for the RSPI.	

Table 1.4 Pin Functions (3/3)

Classifications	Pin Name	I/O	Description
USB 2.0 host/ function module	USB0_DP	I/O	D+ I/O pin of the USB on-chip transceiver.
	USB0_DM	I/O	D- I/O pin of the USB on-chip transceiver.
	USB0_VBUS	Input	USB cable connection monitor pin.
	USB0_EXICEN	Output	Low-power control signal for the OTG chip.
	USB0_VBUSEN	Output	VBUS (5 V) supply enable signal for the OTG chip.
	USB0_OVRCURA, USB0_OVRCURB	Input	External overcurrent detection pins.
	USB0_ID	Input	Mini-AB connector ID input pin during operation in OTG mode.
12-bit A/D converter	AN000 to AN004, AN006, AN008 to AN015	Input	Input pins for the analog signals to be processed by the A/D converter.
	ADTRG0#	Input	Input pin for the external trigger signals that start the A/D conversion.
D/A converter	DA0, DA1	Output	Output pins for the analog signals to be processed by the D/A converter.
I/O ports	P03, P05	I/O	2-bit input/output pins.
	P14 to P17	I/O	4-bit input/output pins.
	P26, P27	I/O	2-bit input/output pins.
	P30 to P32, P35	I/O	4-bit input/output pins (P35 input pin).
	P40 to P44, P46	I/O	6-bit input/output pins.
	P54, P55	I/O	2-bit input/output pins.
	PA0, PA1, PA3, PA4, PA6	I/O	5-bit input/output pins.
	PB0, PB1, PB3, PB5 to PB7	I/O	6-bit input/output pins.
	PC0 to PC7	I/O	8-bit input/output pins.
	PE0 to PE7	I/O	8-bit input/output pins.
	PH7	Input	1-bit input pin.
	PJ6, PJ7	I/O	2-bit input/output pins.

Note 1. For external clock input.

1.5 Pin Assignments

Figure 1.3 to Figure 1.7 show the pin assignments. Table 1.5 to Table 1.9 show the lists of pins and pin functions.

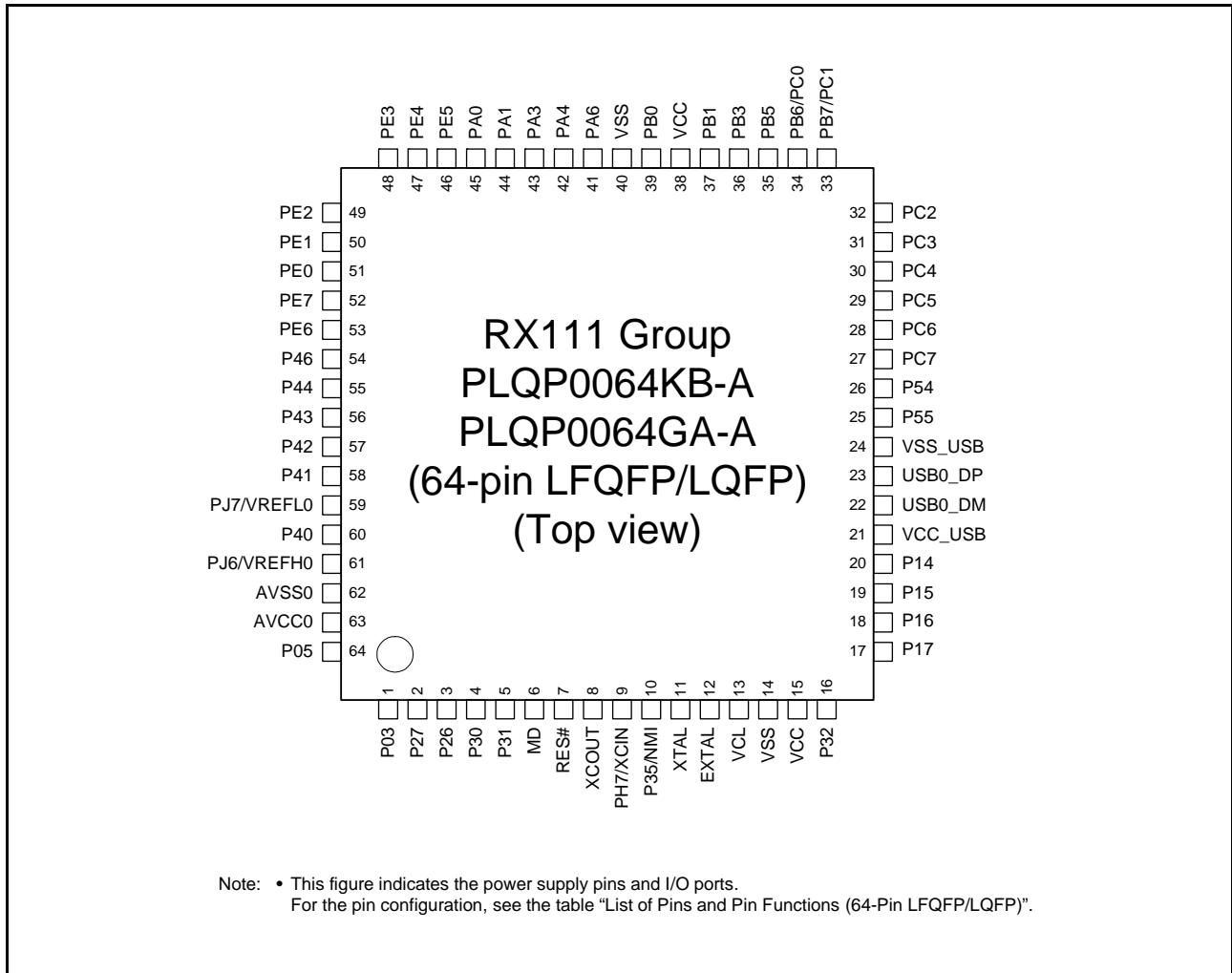

Figure 1.3 Pin Assignments of the 64-Pin LQFP/LQFP

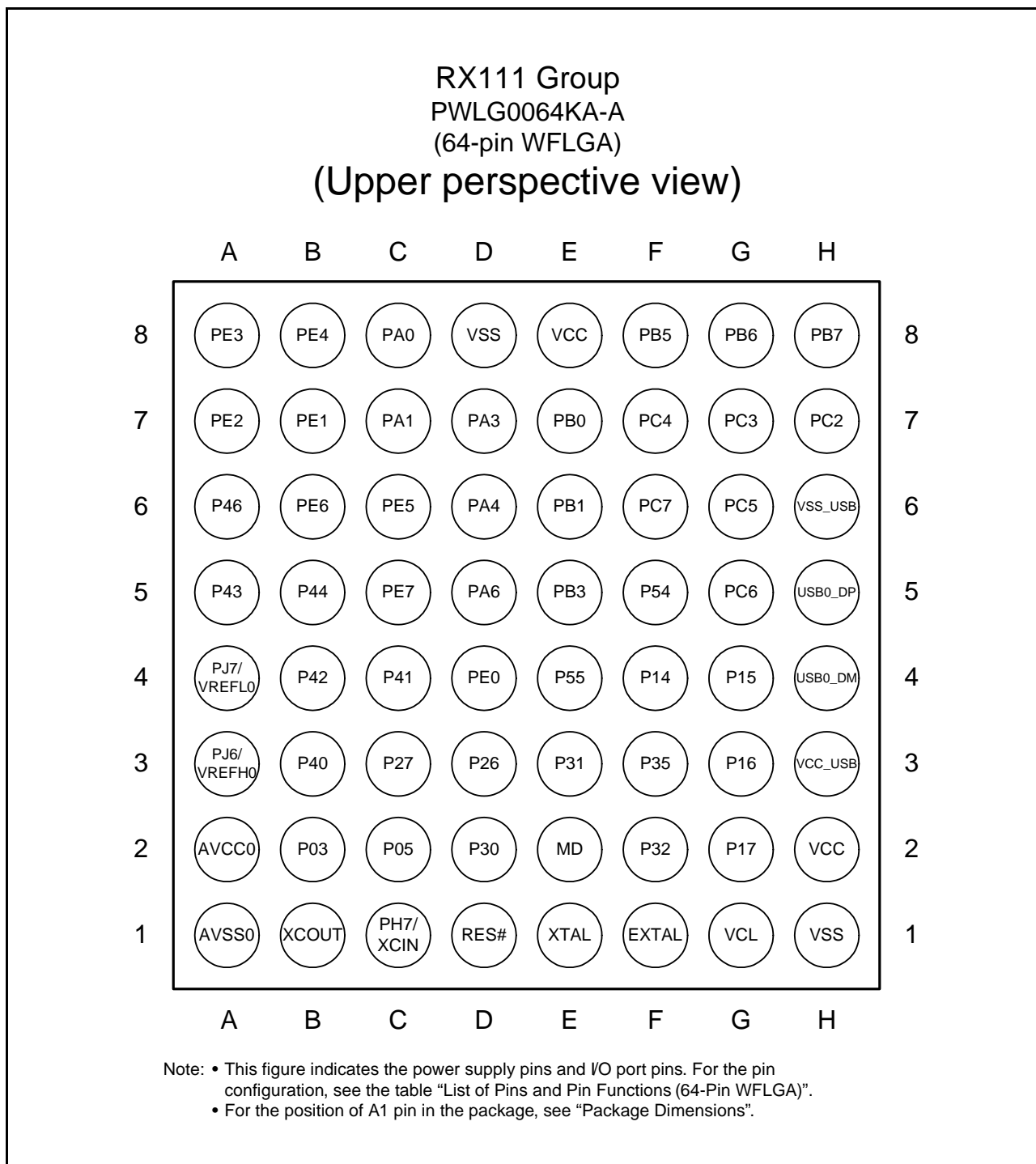
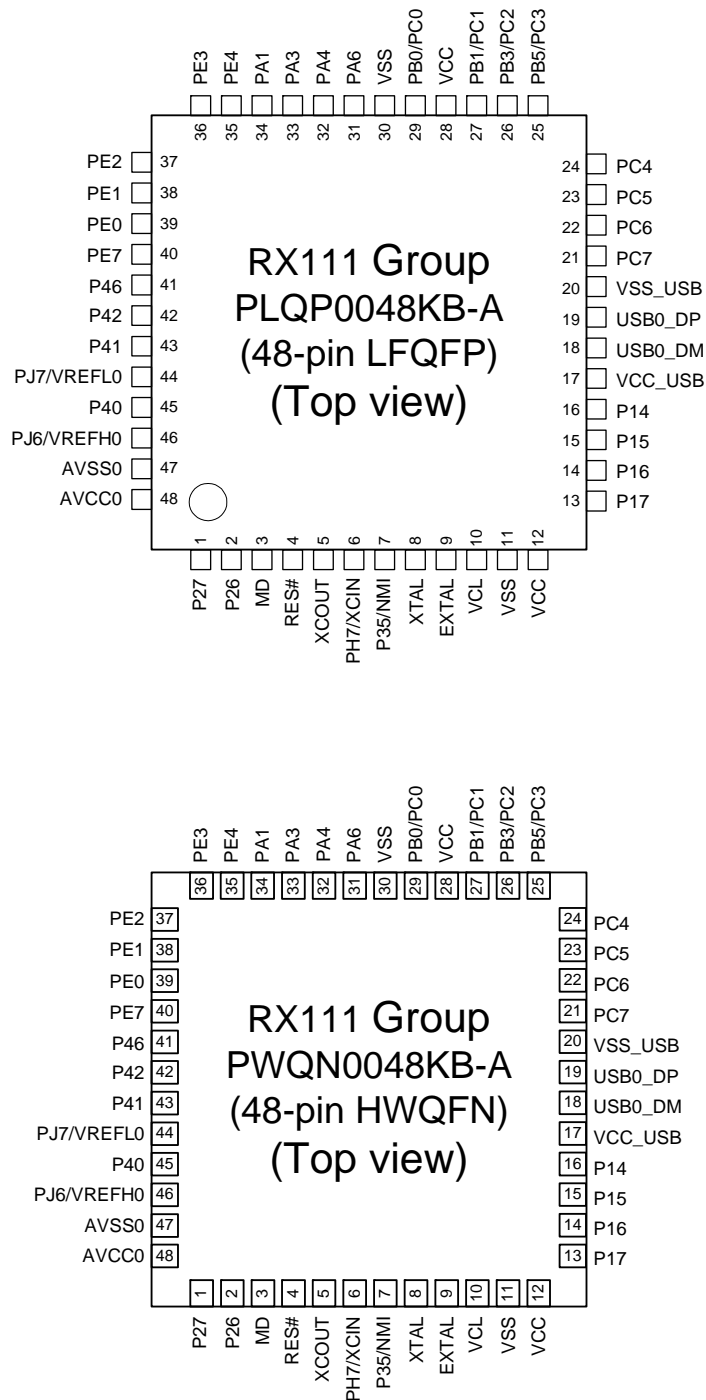

Figure 1.4 Pin Assignments of the 64-Pin WFLGA



- Note:
- This figure indicates the power supply pins and I/O port pins.
For the pin configuration, see the table "List of Pins and Pin Functions (48-Pin LQFP/HWQFN)".
 - It is recommended that the exposed die pad of HWQFN should be connected to VSS.

Figure 1.5 Pin Assignments of the 48-Pin LQFP/HWQFN

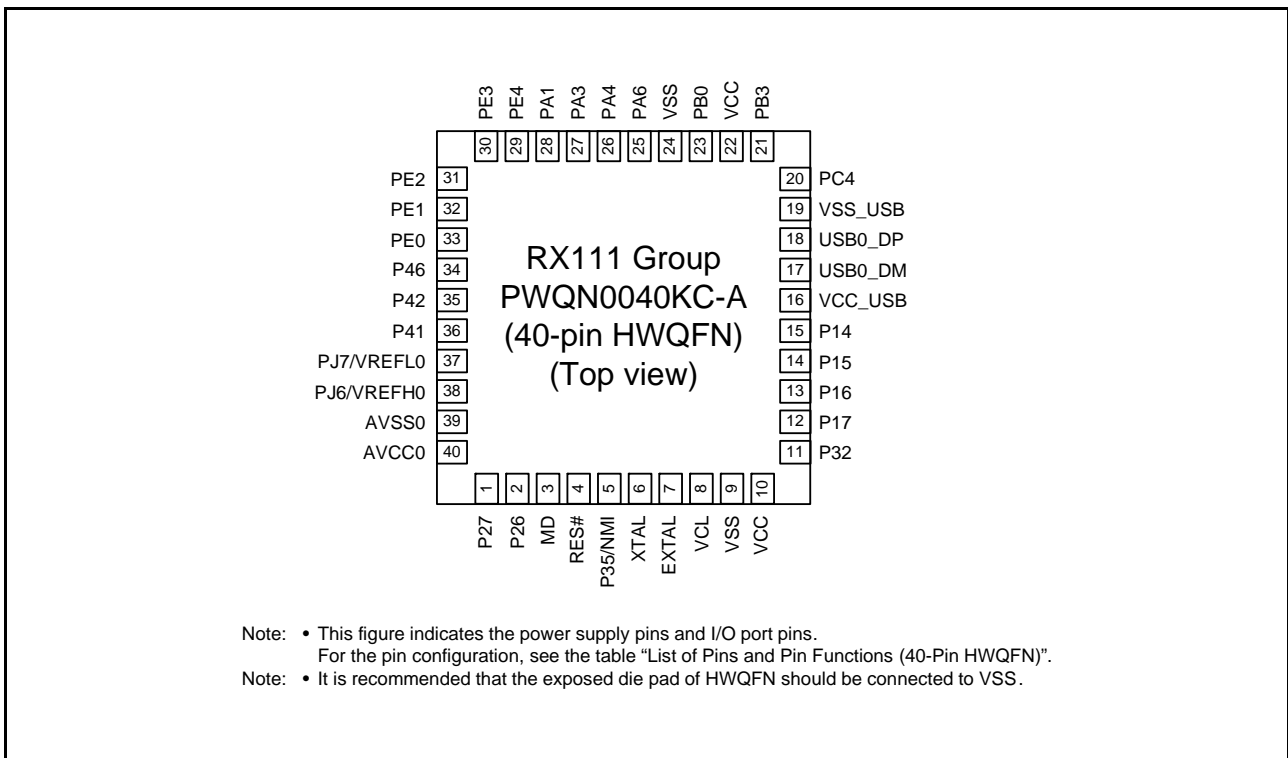

Figure 1.6 Pin Assignments of the 40-Pin HWQFN



Figure 1.7 Pin Assignments of the 36-Pin WFLGA

Table 1.5 List of Pins and Pin Functions (64-Pin LQFP/LQFP) (1/2)

Pin No.	Power Supply, Clock, System Control	I/O Port	Timers (MTU, POE, RTC)	Communication (SCle, SCIf, RSPI, RIIC, USB)	Others
1		P03			DA0
2		P27	MTIOC2B	SCK1/SCK12	IRQ3/CMPA2/ CACREF/ADTRG0#
3		P26	MTIOC2A	TXD1/SMOS1/SSDA1/USB0_VBUSEN	
4		P30	MTIOC4B/POE8#	RXD1/SMISO1/SSCL1	IRQ0
5		P31	MTIOC4D	CTS1#/RTS1#/SS1#	IRQ1
6	MD				FINED
7	RES#				
8	XCOUT				
9	XCIN	PH7			
10	UPSEL	P35			NMI
11	XTAL				
12	EXTAL				
13	VCL				
14	VSS				
15	VCC				
16		P32	MTIOC0C/RTCOUT		IRQ2
17		P17	MTIOC0C/MTIOC3A/ MTIOC3B/POE8#	SCK1/MISOA/SDA0/RXD12/RXD12/ SMISO12/SSCL12	IRQ7
18		P16	MTIOC3C/MTIOC3D/ RTCOUT	TXD1/SMOS1/SSDA1/MOSIA/SCL0/ USB0_VBUS/USB0_VBUSEN/ USB0_OVRCURB	IRQ6/ADTRG0#
19		P15	MTIOC0B/MTCLKB	RXD1/SMISO1/SSCL1/RSPCKA	IRQ5/CLKOUT
20	UB#	P14	MTIOC0A/MTIOC3A/ MTCLKA	CTS1#/RTS1#/SS1#/SSLA0/TXD12/ TXD12/SIOX12/SMOS112/SSDA12/ USB0_OVRCURA	IRQ4
21	VCC_USB				
22				USB0_DM	
23				USB0_DP	
24	VSS_USB				
25		P55	MTIOC4D		
26		P54	MTIOC4B		
27		PC7	MTIOC3A/MTCLKB	TXD1/SMOS1/SSDA1/MISOA/ USB0_OVRCURB	CACREF
28		PC6	MTIOC3C/MTCLKA	RXD1/SMISO1/SSCL1/MOSIA/ USB0_EXICEN	
29		PC5	MTIOC3B/MTCLKD	SCK1/RSPCKA/USB0_ID	
30		PC4	MTIOC3D/MTCLKC/POE0#	SCK5/SSLA0/USB0_VBUS*/ USB0_VBUSEN	IRQ2/CLKOUT
31		PC3	MTIOC4D	TXD5/SMOS5/SSDA5	
32		PC2	MTIOC4B	RXD5/SMISO5/SSCL5/SSLA3	
33		PB7/PC1	MTIOC3B		
34		PB6/PC0	MTIOC3D		
35		PB5	MTIOC2A/MTIOC1B/POE1#		
36		PB3	MTIOC0A/MTIOC3B/ MTIOC4A/POE3#	USB0_OVRCURA	
37		PB1	MTIOC0C/MTIOC4C		IRQ4
38	VCC				
39		PB0	MTIC5W/MTIOC0C/ RTCOUT	SCL0/RSPCKA	IRQ2/ADTRG0#
40	VSS				
41		PA6	MTIC5V/MTCLKB/MTIOC2A/ POE2#	CTS5#/RTS5#/SS5#/SDA0/MOSIA	IRQ3

Table 1.5 List of Pins and Pin Functions (64-Pin LQFP/LQFP) (2/2)

Pin No.	Power Supply, Clock, System Control	I/O Port	Timers (MTU, POE, RTC)	Communication (SCle, SCIf, RSPI, RIIC, USB)	Others
42		PA4	MTIC5U/MTCLKA/MTIOC2B	TXD5/SMOSI5/SSDA5/SSLA0	IRQ5
43		PA3	MTIOC0D/MTCLKD/MTIOC1B/POE0#	RXD5/SMISO5/SSCL5/MISOA	IRQ6
44		PA1	MTIOC0B/MTCLKC/RTCOUT	SCK5/SSLA2	
45		PA0	MTIOC4A	SSLA1	CACREF
46		PE5	MTIOC4C/MTIOC2B		IRQ5/AN013
47		PE4	MTIOC4D/MTIOC1A/MTIOC3A	MOSIA	IRQ4/AN012
48		PE3	MTIOC0A/MTIOC1B/MTIOC4B/POE8#	CTS12#/RTS12#/SS12#/RSPCKA	IRQ3/AN011
49		PE2	MTIOC4A	RXD12/RXDX12/SMISO12/SSCL12	IRQ7/AN010
50		PE1	MTIOC4C	TXD12/TXDX12/SIOX12/SMOSI12/SSDA12	IRQ1/AN009
51		PE0	MTIOC2A/POE3#	SCK12	IRQ0/AN008
52		PE7			IRQ7/AN015
53		PE6			IRQ6/AN014
54		P46*2			AN006
55		P44*2			AN004
56		P43*2			AN003
57		P42*2			AN002
58		P41*2			AN001
59	VREFL0	PJ7*2			
60		P40*2			AN000
61	VREFH0	PJ6*2			
62	AVSS0				
63	AVCC0				
64		P05			DA1

Note 1. Not 5 V tolerant.

Note 2. The power source of the I/O buffer for these pins is AVCC0.

Table 1.6 List of Pins and Pin Functions (64-Pin WFLGA) (1/2)

Pin No.	Power Supply, Clock, System Control	I/O Port	Timers (MTU, POE, RTC)	Communication (SCIE, SCIf, RSPI, RIIC, USB)	Others
A1	AVSS0				
A2	AVCC0				
A3	VREFH0	PJ6*2			
A4	VREFL0	PJ7*2			
A5		P43*2			AN003
A6		P46*2			AN006
A7		PE2	MTIOC4A	RXD12/RXDX12/SMISO12/SSCL12	IRQ7/AN010
A8		PE3	MTIOC0A/MTIOC1B/ MTIOC4B/POE8#	CTS12#/RTS12#/SS12#/RSPCKA	IRQ3/AN011
B1	XCOUT				
B2		P03			DA0
B3		P40*2			AN000
B4		P42*2			AN002
B5		P44*2			AN004
B6		PE6			IRQ6/AN014
B7		PE1	MTIOC4C	TXD12/TXDX12/SIOX12/SMOSI12/ SSDA12	IRQ1/AN009
B8		PE4	MTIOC1A/MTIOC3A/ MTIOC4D	MOSIA	IRQ4/AN012
C1	XCIN	PH7			
C2		P05			DA1
C3		P27	MTIOC2B	SCK1/SCK12	IRQ3/MPA2/CACREF/ ADTRG0#
C4		P41*2			AN001
C5		PE7			IRQ7/AN015
C6		PE5	MTIOC2B/MTIOC4C		IRQ5/AN013
C7		PA1	MTIOC0B/MTCLKC/ RTCOUT	SCK5/SSLA2	
C8		PA0	MTIOC4A	SSLA1	CACREF
D1	RES#				
D2		P30	MTIOC4B/POE8#	RXD1/SMISO1/SSCL1	IRQ0
D3		P26	MTIOC2A	TXD1/SMOSI1/SSDA1/ USB0_VBUSEN	
D4		PE0	MTIOC2A/POE3#	SCK12	IRQ0/AN008
D5		PA6	MTIC5V/MTIOC2A/MTCLKB/ POE2#	CTS5#/RTS5#/SS5#/SDA0/MOSIA	IRQ3
D6		PA4	MTIC5U/MTIOC2B/MTCLKA	TXD5/SMOSI5/SSDA5/SSLA0	IRQ5
D7		PA3	MTIOC0D/MTCLKD/ MTIOC1B/POE0#	RXD5/SMISO5/SSCL5/MISOA	IRQ6
D8	VSS				
E1	XTAL				
E2	MD				FINED
E3		P31	MTIOC4D	CTS1#/RTS1#/SS1#	IRQ1
E4		P55	MTIOC4D		
E5		PB3	MTIOC0A/MTIOC3B/ MTIOC4A/POE3#	USB0_OVRCURA	
E6		PB1	MTIOC0C/MTIOC4C		IRQ4
E7		PB0	MTIC5W/MTIOC0C/ RTCOUT	SCL0/RSPCKA	IRQ2/ADTRG0#
E8	VCC				
F1	EXTAL				

Table 1.6 List of Pins and Pin Functions (64-Pin WFLGA) (2/2)

Pin No.	Power Supply, Clock, System Control	I/O Port	Timers (MTU, POE, RTC)	Communication (SCIE, SCIF, RSPI, RIIC, USB)	Others
F2		P32	MTIOC0C/RTCOU		IRQ2
F3	UPSEL	P35			NMI
F4	UB#	P14	MTIOC0A/MTIOC3A/MTCLKA	CTS1#/RTS1#/SS1#/TXD12/TXD12/SIOX12/SMOSI12/SSDA12/SSLA0/USB0_OVRCURA	IRQ4
F5		P54	MTIOC4B		
F6		PC7	MTIOC3A/MTCLKB	TXD1/SMOSI1/SSDA1/MISOA/USB0_OVRCURB	CACREF
F7		PC4	MTCLKC/MTIOC3D/POE0#	SCK5/SSLA0/USB0_VBUSEN/USB0_VBUS*1	IRQ2/CLKOUT
F8		PB5	MTIOC1B/MTIOC2A/POE1#		
G1	VCL				
G2		P17	MTIOC0C/MTIOC3A/MTIOC3B/POE8#	SCK1/MISOA/SDA0/RXD12/RDX12/SMISO12/SSCL12	IRQ7
G3		P16	MTIOC3C/MTIOC3D/RTCOU	TXD1/SMOSI1/SSDA1/SCL0/MOSIA/USB0_VBUSEN/USB0_OVRCURB/USB0_VBUS	IRQ6/ADTRG0#
G4		P15	MTIOC0B/MTCLKB	RXD1/SMISO1/SSCL1/RSPCKA	IRQ5/CLKOUT
G5		PC6	MTIOC3C/MTCLKA	RXD1/SMISO1/SSCL1/MOSIA/USB0_EXICEN	
G6		PC5	MTIOC3B/MTCLKD	SCK1/RSPCKA/USB0_ID	
G7		PC3	MTIOC4D	TXD5/SMOSI5/SSDA5	
G8		PB6/PC0	MTIOC3D		
H1	VSS				
H2	VCC				
H3	VCC_USB				
H4				USB0_DM	
H5				USB0_DP	
H6	VSS_USB				
H7		PC2	MTIOC4B	RXD5/SMISO5/SSCL5/SSLA3	
H8		PB7/PC1	MTIOC3B		

Note 1. Not 5 V tolerant.

Note 2. The power source of the I/O buffer for these pins is AVCC0.

Table 1.7 List of Pins and Pin Functions (48-Pin LQFP/HWQFN) (1/2)

Pin No.	Power Supply, Clock, System Control	I/O Port	Timers (MTU, POE, RTC)	Communication (SCle, SCIf, RSPI, RIIC, USB)	Others
1		P27	MTIOC2B	SCK1/SCK12	IRQ3/CMPA2/ CACREF/ADTRG0#
2		P26	MTIOC2A	TXD1/SMOSI1/SSDA1/USB0_VBUSEN	
3	MD				FINED
4	RES#				
5	XCOUT				
6	XCIN	PH7			
7	UPSEL	P35			NMI
8	XTAL				
9	EXTAL				
10	VCL				
11	VSS				
12	VCC				
13		P17	MTIOC0C/MTIOC3A/ MTIOC3B/POE8#	SCK1/MISOA/SDA0/RXD12/RDX12/ SMISO12/SSCL12	IRQ7
14		P16	MTIOC3C/MTIOC3D/ RTCOUT	TXD1/SMOSI1/SSDA1/MOSIA/SCL0/ USB0_VBUS/USB0_VBUSEN/ USB0_OVRCURB	IRQ6/ADTRG0#
15		P15	MTIOC0B/MTCLKB	RXD1/SMISO1/SSCL1/RSPCKA	IRQ5/CLKOUT
16	UB#	P14	MTIOC0A/MTIOC3A/ MTCLKA	CTS1#/RTS1#/SS1#/SSLA0/TXD12/ TXDX12/SIOX12/SMOSI12/SSDA12/ USB0_OVRCURA	IRQ4
17	VCC_USB				
18				USB0_DM	
19				USB0_DP	
20	VSS_USB				
21		PC7	MTIOC3A/MTCLKB	TXD1/SMOSI1/SSDA1/MISOA/ USB0_OVRCURB	CACREF
22		PC6	MTIOC3C/MTCLKA	RXD1/SMISO1/SSCL1/MOSIA/ USB0_EXICEN	
23		PC5	MTIOC3B/MTCLKD	SCK1/RSPCKA/USB0_ID	
24		PC4	MTIOC3D/MTCLKC/POE0#	SCK5/SSLA0/USB0_VBUS*1/ USB0_VBUSEN	IRQ2/CLKOUT
25		PB5/PC3	MTIOC2A/MTIOC1B/POE1#		
26		PB3/PC2	MTIOC0A/MTIOC3B/ MTIOC4A/POE3#	USB0_OVRCURA	
27		PB1/PC1	MTIOC0C/MTIOC4C		IRQ4
28	VCC				
29		PB0/PC0	MTIC5W/MTIOC0C/ RTCOUT	SCL0/RSPCKA	IRQ2/ADTRG0#
30	VSS				
31		PA6	MTIC5V/MTCLKB/MTIOC2A/ POE2#	CTS5#/RTS5#/SS5#/SDA0/MOSIA	IRQ3
32		PA4	MTIC5U/MTCLKA/MTIOC2B	TXD5/SMOSI5/SSDA5/SSLA0	IRQ5
33		PA3	MTIOC0D/MTCLKD/ MTIOC1B/POE0#	RXD5/SMISO5/SSCL5/MISOA	IRQ6
34		PA1	MTIOC0B/MTCLKC/ RTCOUT	SCK5/SSLA2	
35		PE4	MTIOC4D/MTIOC1A/ MTIOC3A	MOSIA	IRQ4/AN012
36		PE3	MTIOC0A/MTIOC1B/ MTIOC4B/POE8#	CTS12#/RTS12#/SS12#/RSPCKA	IRQ3/AN011
37		PE2	MTIOC4A	RXD12/RDX12/SMISO12/SSCL12	IRQ7/AN010
38		PE1	MTIOC4C	TXD12/TXDX12/SIOX12/SMOSI12/ SSDA12	IRQ1/AN009

Table 1.7 List of Pins and Pin Functions (48-Pin LFQFP/HWQFN) (2/2)

Pin No.	Power Supply, Clock, System Control	I/O Port	Timers (MTU, POE, RTC)	Communication (SCle, SCIf, RSPI, RIIC, USB)	Others
39		PE0	MTIOC2A/POE3#	SCK12	IRQ0/AN008
40		PE7			IRQ7/AN015
41		P46*2			AN006
42		P42*2			AN002
43		P41*2			AN001
44	VREFL0	PJ7*2			
45		P40*2			AN000
46	VREFH0	PJ6*2			
47	AVSS0				
48	AVCC0				

Note 1. Not 5 V tolerant.

Note 2. The power source of the I/O buffer for these pins is AVCC0.

Table 1.8 List of Pins and Pin Functions (40-Pin HWQFN) (1/2)

Pin No.	Power Supply, Clock, System Control	I/O Port	Timers (MTU, POE, RTC)	Communication (SCIE, SCIf, RSPI, RIIC, USB)	Others
1		P27	MTIOC2B	SCK1/SCK12	IRQ3/CMPA2/CACREF/ADTRG0#
2		P26	MTIOC2A	TXD1/SMOSI1/SSDA1/USB0_VBUSEN	
3	MD				FINED
4	RES#				
5	UPSEL	P35			NMI
6	XTAL				
7	EXTAL				
8	VCL				
9	VSS				
10	VCC				
11		P32	MTIOC0C		IRQ2
12		P17	MTIOC0C/MTIOC3A/MTIOC3B/POE8#	SCK1/MISOA/SDA0/RXD12/RDX12/SMISO12/SSCL12	IRQ7
13		P16	MTIOC3C/MTIOC3D	TXD1/SMOSI1/SSDA1/SCL0/MOSIA/USB0_VBUSEN/USB0_OVRCURB/USB0_VBUS	IRQ6/ADTRG0#
14		P15	MTIOC0B/MTCLKB	RXD1/SMISO1/SSCL1/RSPCKA	IRQ5/CLKOUT
15	UB#	P14	MTIOC0A/MTIOC3A/MTCLKA	CTS1#/RTS1#/SS1#/SSLA0/TXD12/TXD12/SIOX12/SMOSI12/SSDA12/USB0_OVRCURA	IRQ4
16	VCC_USB				
17				USB0_DM	
18				USB0_DP	
19	VSS_USB				
20		PC4	MTIOC3D/MTCLKC/POE0#	SCK5/SSLA0/USB0_VBUS*/USB0_VBUSEN	IRQ2/CLKOUT
21		PB3	MTIOC0A/MTIOC3B/MTIOC4A/POE3#	USB0_OVRCURA	
22	VCC				
23		PB0	MTIOC0C/MTIC5W	SCL0/RSPCKA	IRQ2/ADTRG0#
24	VSS				
25		PA6	MTIOC2A/MTIC5V/MTCLKB/POE2#	CTS5#/RTS5#/SS5#/SDA0/MOSIA	IRQ3
26		PA4	MTIOC2B/MTIC5U/MTCLKA	TXD5/SMOSI5/SSDA5/SSLA0	IRQ5
27		PA3	MTIOC0D/MTIOC1B/MTCLKD/POE0#	RXD5/SMISO5/SSCL5/MISOA	IRQ6
28		PA1	MTIOC0B/MTCLKC	SCK5/SSLA2	
29		PE4	MTIOC1A/MTIOC3A/MTIOC4D	MOSIA	IRQ4/AN012
30		PE3	MTIOC0A/MTIOC1B/MTIOC4B/POE8#	CTS12#/RTS12#/SS12#/RSPCKA	IRQ3/AN011
31		PE2	MTIOC4A	RXD12/RDX12/SMISO12/SSCL12	IRQ7/AN010
32		PE1	MTIOC4C	TXD12/TXD12/SIOX12/SMOSI12/SSDA12	IRQ1/AN009
33		PE0	MTIOC2A/POE3#	SCK12	IRQ0/AN008
34		P46*2			AN006
35		P42*2			AN002
36		P41*2			AN001
37	VREFL0	PJ7*2			
38	VREFH0	PJ6*2			
39	AVSS0				

Table 1.8 List of Pins and Pin Functions (40-Pin HWQFN) (2/2)

Pin No.	Power Supply, Clock, System Control	I/O Port	Timers (MTU, POE, RTC)	Communication (SCIE, SCIF, RSPI, RIIC, USB)	Others
40	AVCC0				

Note 1. Not 5 V tolerant.

Note 2. The power source of the I/O buffer for these pins is AVCC0.

Table 1.9 List of Pins and Pin Functions (36-Pin WFLGA)

Pin No.	Power Supply, Clock, System Control	I/O Port	Timers (MTU, POE, RTC)	Communication (SCIE, SCIf, RSPI, RIIC, USB)	Others
A1	AVSS0				
A2	AVCC0				
A3	VREFH0	PJ6*2			
A4		P42*2			AN002
A5		P41*2			AN001
A6		PE2	MTIOC4A	RXD12/RXD12/SMISO12/SSCL12	IRQ7/AN010
B1	RES#				
B2		P27	MTIOC2B	SCK1/SCK12	IRQ3/CMPA2/CACREF/ADTRG0#
B3	VREFL0	PJ7*2			
B4		PE0	MTIOC2A/POE3#	SCK12	IRQ0/AN008
B5		PE1	MTIOC4C	TXD12/TXD12/SIOX12/SMOSI12/SSDA12	IRQ1/AN009
B6		PA3	MTIOC0D/MTCLKD/MTIOC1B/POE0#	RXD5/SMISO5/SSCL5/MISOA	IRQ6
C1	XTAL				
C2	MD				FINED
C3		PE3	MTIOC0A/MTIOC1B/MTIOC4B/POE8#	CTS12#/RTS12#/SS12#/RSPCKA	IRQ3/AN011
C4		PE4	MTIOC1A/MTIOC3A/MTIOC4D	MOSIA	IRQ4/AN012
C5		PA4	MTIOC2B/MTIC5U/MTCLKA	TXD5/SMOSI5/SSDA5/SSLA0	IRQ5
C6	VSS				
D1	EXTAL				
D2	UPSEL	P35			NMI
D3	UB#	P14	MTIOC0A/MTIOC3A/MTCLKA	CTS1#/RTS1#/SS1#/SSLA0/TXD12/TXD12/SIOX12/SMOSI12/SSDA12/USB0_OVRCURA	IRQ4
D4		PA6	MTIC5V/MTCLKB/MTIOC2A/POE2#	CTS5#/RTS5#/SS5#/SDA0/MOSIA	IRQ3
D5		PB3	MTIOC0A/MTIOC3B/MTIOC4A/POE3#	USB0_OVRCURA	
D6		PB0	MTIOC0C/MTIC5W	SCL0/RSPCKA	IRQ2/ADTRG0#
E1	VCL				
E2		P17	MTIOC0C/MTIOC3A/MTIOC3B/POE8#	SCK1/MISOA/SDA0/RXD12/RXD12/SMISO12/SSCL12	IRQ7
E3		P16	MTIOC3C/MTIOC3D	TXD1/SMOSI1/SSDA1/SCL0/MOSIA/USB0_VBUSEN/USB0_OVRCURB/USB0_VBUS	IRQ6/ADTRG0#
E4		P15	MTIOC0B/MTCLKB	RXD1/SMISO1/SSCL1/RSPCKA	IRQ5/CLKOUT
E5		PC4	MTIOC3D/MTCLKC/POE0#	SCK5/SSLA0/USB0_VBUSEN/USB0_VBUS*1	IRQ2/CLKOUT
E6	VCC				
F1	VSS				
F2	VCC				
F3	VCC_USB				
F4				USB0_DM	
F5				USB0_DP	
F6	VSS_USB				

Note 1. Not 5 V tolerant.

Note 2. The power source of the I/O buffer for these pins is AVCC0.

2. CPU

Figure 2.1 shows the register set of the CPU.

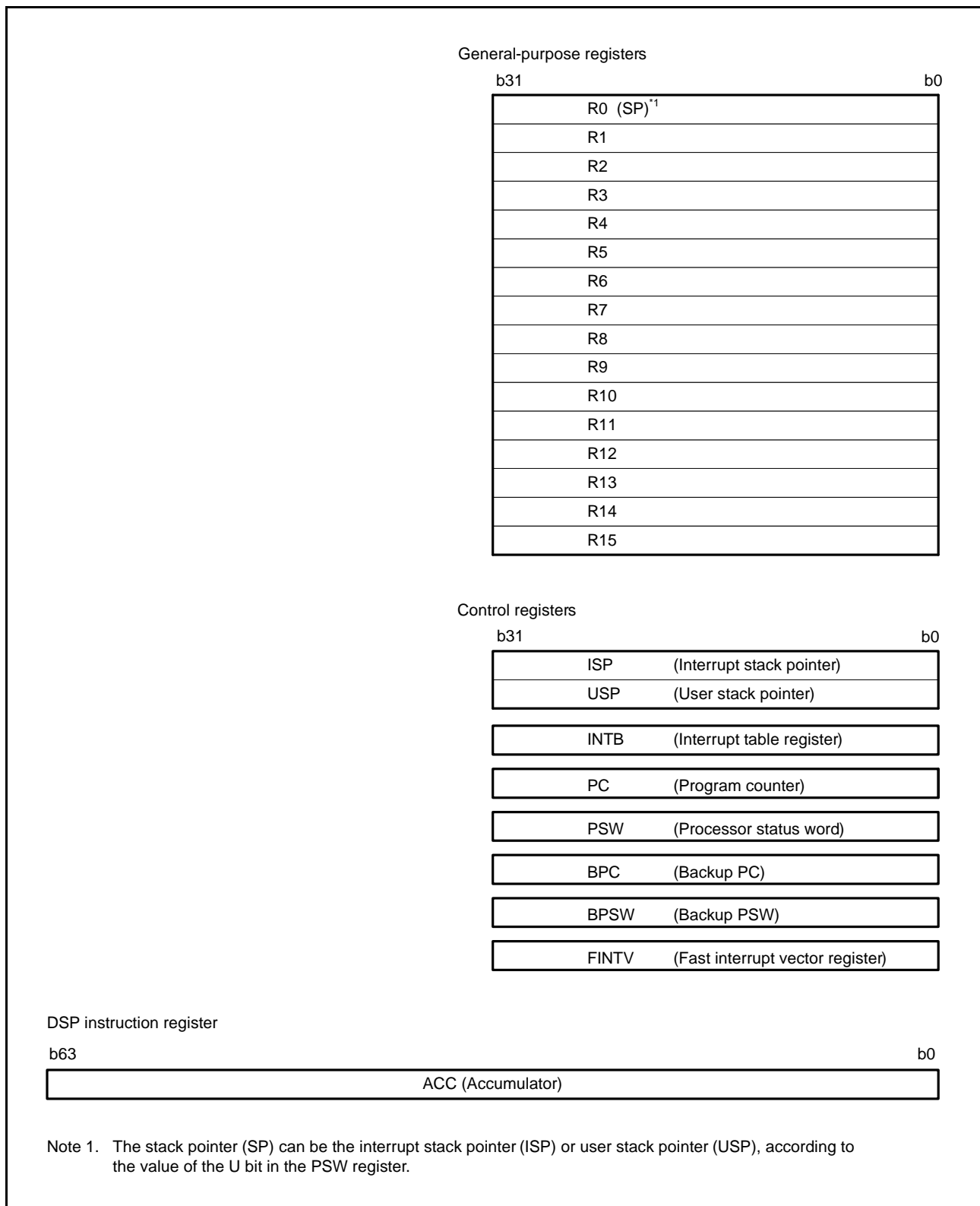

Figure 2.1 Register Set of the CPU

2.1 General-Purpose Registers (R0 to R15)

This CPU has 16 general-purpose registers (R0 to R15). R0 to R15 can be used as data registers or address registers. R0, a general-purpose register, also functions as the stack pointer (SP). The stack pointer is switched to operate as the interrupt stack pointer (ISP) or user stack pointer (USP) by the value of the stack pointer select bit (U) in the processor status word (PSW).

2.2 Control Registers

(1) Interrupt Stack Pointer (ISP)/User Stack Pointer (USP)

The stack pointer (SP) can be either of two types, the interrupt stack pointer (ISP) or the user stack pointer (USP). Whether the stack pointer operates as the ISP or USP depends on the value of the stack pointer select bit (U) in the processor status word (PSW).

Set the ISP or USP to a multiple of 4, as this reduces the numbers of cycles required to execute interrupt sequences and instructions entailing stack manipulation.

(2) Interrupt Table Register (INTB)

The interrupt table register (INTB) specifies the address where the relocatable vector table starts.

(3) Program Counter (PC)

The program counter (PC) indicates the address of the instruction being executed.

(4) Processor Status Word (PSW)

The processor status word (PSW) indicates the results of instruction execution or the state of the CPU.

(5) Backup PC (BPC)

The backup PC (BPC) is provided to speed up response to interrupts.

After a fast interrupt has been generated, the contents of the program counter (PC) are saved in the BPC register.

(6) Backup PSW (BPSW)

The backup PSW (BPSW) is provided to speed up response to interrupts.

After a fast interrupt has been generated, the contents of the processor status word (PSW) are saved in the BPSW. The allocation of bits in the BPSW corresponds to that in the PSW.

(7) Fast Interrupt Vector Register (FINTV)

The fast interrupt vector register (FINTV) is provided to speed up response to interrupts.

The FINTV register specifies a branch destination address when a fast interrupt has been generated.

2.3 Register Associated with DSP Instructions

(1) Accumulator (ACC)

The accumulator (ACC) is a 64-bit register used for DSP instructions. The accumulator is also used for the multiply and multiply-and-accumulate instructions; EMUL, EMULU, MUL, and RMPA, in which case the prior value in the accumulator is modified by execution of the instruction.

Use the MVTACHI and MVTACLO instructions for writing to the accumulator. The MVTACHI and MVTACLO instructions write data to the higher-order 32 bits (bits 63 to 32) and the lower-order 32 bits (bits 31 to 0), respectively.

Use the MVFACHI and MVFACMI instructions for reading data from the accumulator. The MVFACHI and MVFACMI instructions read data from the higher-order 32 bits (bits 63 to 32) and the middle 32 bits (bits 47 to 16), respectively.

3. Address Space

3.1 Address Space

This MCU has a 4-Gbyte address space, consisting of the range of addresses from 0000 0000h to FFFF FFFFh. That is, linear access to an address space of up to 4 Gbytes is possible, and this contains both program and data areas.

Figure 3.1 shows the memory map.

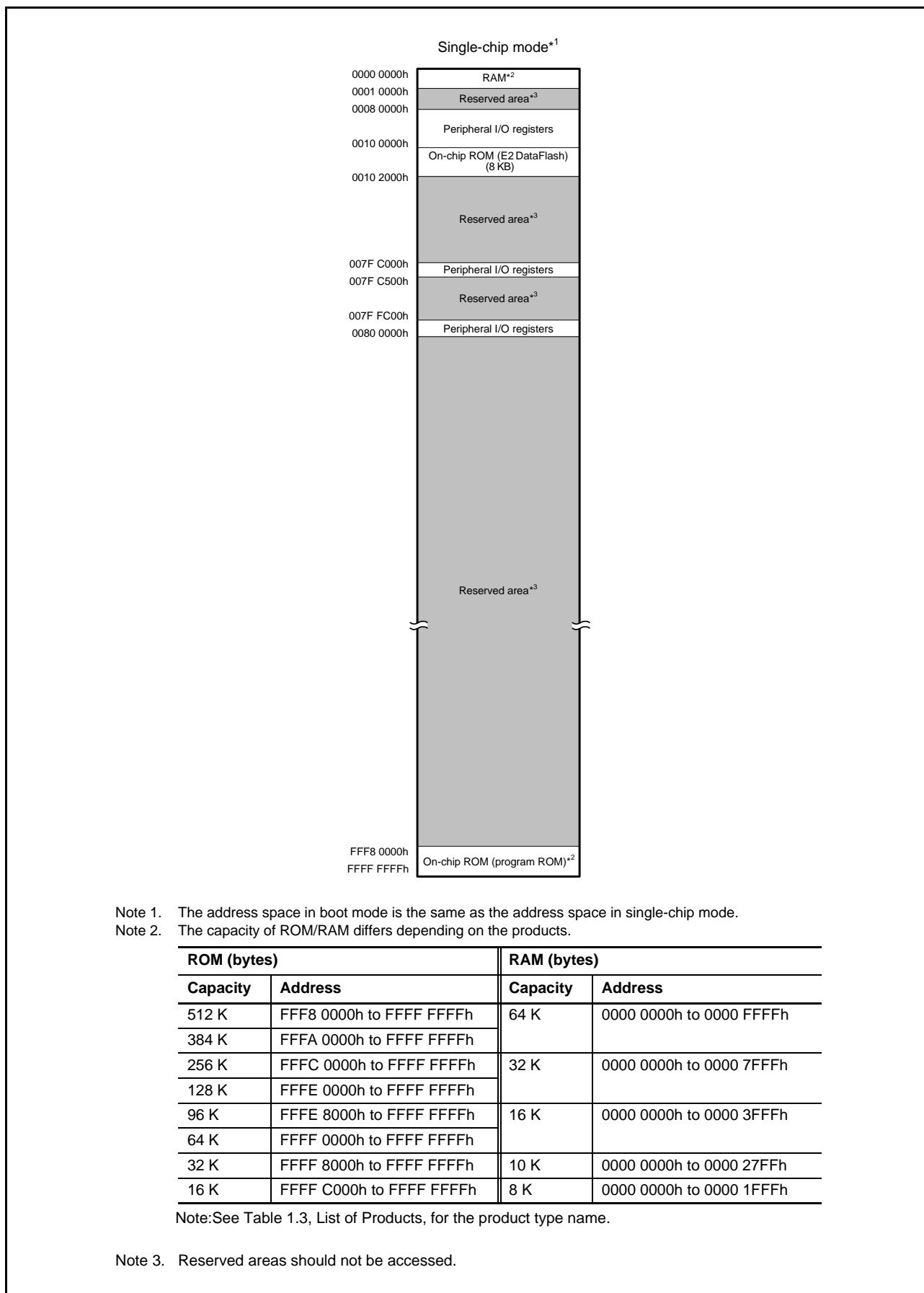

Figure 3.1 Memory Map

4. I/O Registers

This section provides information on the on-chip I/O register addresses and bit configuration. The information is given as shown below. Notes on writing to I/O registers are also given below.

(1) I/O register addresses (address order)

- Registers are listed from the lower allocation addresses.
- Registers are classified according to module symbols.
- Numbers of cycles for access indicate numbers of cycles of the given base clock.
- Among the internal I/O register area, addresses not listed in the list of registers are reserved. Reserved addresses must not be accessed. Do not access these addresses; otherwise, the operation when accessing these bits and subsequent operations cannot be guaranteed.

(2) Notes on writing to I/O registers

While writing to an I/O register, the CPU starts executing subsequent instructions before the I/O register write access is completed. This may cause the subsequent instructions to be executed before the write value is reflected in the operation. The examples below show how subsequent instructions must be executed after a write access to an I/O register is completed.

[Examples of cases requiring special care]

- The subsequent instruction must be executed while an interrupt request is disabled with the IENj bit in IERN of the ICU (interrupt request enable bit) set to 0.
- A WAIT instruction is executed immediately after the preprocessing for causing a transition to the low power consumption state.

In the above cases, after writing to an I/O register, wait until the write operation is completed using the following procedure and then execute the subsequent instruction.

- Write to an I/O register.
- Read the value in the I/O register and write it to a general register.
- Execute the operation using the value read.
- Execute the subsequent instruction.

Example of instructions

- Byte-size I/O registers

```
MOV.L #SFR_ADDR, R1
MOV.B #SFR_DATA, [R1]
CMP [R1].UB, R1
;; Next process
```

- Word-size I/O registers

```
MOV.L #SFR_ADDR, R1
MOV.W #SFR_DATA, [R1]
CMP [R1].W, R1
;; Next process
```

- Longword-size I/O registers

```
MOV.L #SFR_ADDR, R1
MOV.L #SFR_DATA, [R1]
CMP [R1].L, R1
;; Next process
```

When executing an instruction after writing to multiple registers, only read the last I/O register written to and execute the instruction using that value; it is not necessary to execute the instruction using the values written to all the registers.

(3) Number of cycles necessary for accessing I/O registers

See Table 4.1 for details on the number of clock cycles necessary for accessing I/O registers.

The number of access cycles to I/O registers is obtained by following equation.*1

$$\begin{aligned} \text{Number of access cycles to I/O registers} = & \text{Number of bus cycles for internal main bus 1} + \\ & \text{Number of divided clock synchronization cycles} + \\ & \text{Number of bus cycles for internal peripheral buses 1 to 6} \end{aligned}$$

The number of bus cycles of internal peripheral buses 1 to 6 differs according to the register to be accessed.

When peripheral functions connected to internal peripheral buses 2 to 6 or registers for the external bus control unit (except for bus error related registers) are accessed, the number of divided clock synchronization cycles is added.

The number of divided clock synchronization cycles differs depending on the frequency ratio between ICLK and PCLK (or FCLK) or bus access timing.

In the peripheral function unit, when the frequency ratio of ICLK is equal to or greater than that of PCLK (or FCLK), the sum of the number of bus cycles for internal main bus 1 and the number of the divided clock synchronization cycles will be one cycle of PCLK (or FCLK) at a maximum. Therefore, one PCLK (or FCLK) has been added to the number of access cycles shown in Table 4.1.

When the frequency ratio of ICLK is lower than that of PCLK (or FCLK), the subsequent bus access is started from the ICLK cycle following the completion of the access to the peripheral functions. Therefore, the access cycles are described on an ICLK basis.

Note 1. This applies to the number of cycles when the access from the CPU does not conflict with the bus access from the different bus master (DTC).

(4) Notes on sleep mode and mode transitions

During sleep mode or mode transitions, do not write to the system control related registers (indicated by 'SYSTEM' in the Module Symbol column in Table 4.1, List of I/O Registers (Address Order)).

4.1 I/O Register Addresses (Address Order)

Table 4.1 List of I/O Registers (Address Order) (1/16)

Address	Module Symbol	Register Name	Register Symbol	Number of Bits	Access Size	Number of Access States
0008 0000h	SYSTEM	Mode Monitor Register	MDMONR	16	16	3 ICLK
0008 0008h	SYSTEM	System Control Register 1	SYSCR1	16	16	3 ICLK
0008 000Ch	SYSTEM	Standby Control Register	SBYCR	16	16	3 ICLK
0008 0010h	SYSTEM	Module Stop Control Register A	MSTPCRA	32	32	3 ICLK
0008 0014h	SYSTEM	Module Stop Control Register B	MSTPCRB	32	32	3 ICLK
0008 0018h	SYSTEM	Module Stop Control Register C	MSTPCRC	32	32	3 ICLK
0008 0020h	SYSTEM	System Clock Control Register	SCKCR	32	32	3 ICLK
0008 0026h	SYSTEM	System Clock Control Register 3	SCKCR3	16	16	3 ICLK
0008 0028h	SYSTEM	PLL Control Register	PLLCR	16	16	3 ICLK
0008 002Ah	SYSTEM	PLL Control Register 2	PLLCR2	8	8	3 ICLK
0008 0032h	SYSTEM	Main Clock Oscillator Control Register	MOSCCR	8	8	3 ICLK
0008 0033h	SYSTEM	Sub-Clock Oscillator Control Register	SOSCCR	8	8	3 ICLK
0008 0034h	SYSTEM	Low-Speed On-Chip Oscillator Control Register	LOCOCR	8	8	3 ICLK
0008 0035h	SYSTEM	IWDT-Dedicated On-Chip Oscillator Control Register	ILOCOCR	8	8	3 ICLK
0008 0036h	SYSTEM	High-Speed On-Chip Oscillator Control Register	HOCOCR	8	8	3 ICLK
0008 003Ch	SYSTEM	Oscillation Stabilization Flag Register	OSCOVFSR	8	8	3 ICLK
0008 003Eh	SYSTEM	CLKOUT Output Control Register	CKOCR	16	16	3 ICLK
0008 0040h	SYSTEM	Oscillation Stop Detection Control Register	OSTDCR	8	8	3 ICLK
0008 0041h	SYSTEM	Oscillation Stop Detection Status Register	OSTDSR	8	8	3 ICLK
0008 00A0h	SYSTEM	Operating Power Control Register	OPCCR	8	8	3 ICLK
0008 00A1h	SYSTEM	Sleep Mode Return Clock Source Switching Register	RSTCKCR	8	8	3 ICLK
0008 00A2h	SYSTEM	Main Clock Oscillator Wait Control Register	MOSCWTCR	8	8	3 ICLK
0008 00A5h	SYSTEM	High-Speed On-Chip Oscillator Wait Control Register	HOCOWTCR	8	8	3 ICLK
0008 00AAh	SYSTEM	Sub Operating Power Control Register	SOPCCR	8	8	3 ICLK
0008 00C0h	SYSTEM	Reset Status Register 2	RSTSR2	8	8	3 ICLK
0008 00C2h	SYSTEM	Software Reset Register	SWRR	16	16	3 ICLK
0008 00E0h	SYSTEM	Voltage Monitoring 1 Circuit Control Register 1	LVD1CR1	8	8	3 ICLK
0008 00E1h	SYSTEM	Voltage Monitoring 1 Circuit Status Register	LVD1SR	8	8	3 ICLK
0008 00E2h	SYSTEM	Voltage Monitoring 2 Circuit Control Register 1	LVD2CR1	8	8	3 ICLK
0008 00E3h	SYSTEM	Voltage Monitoring 2 Circuit Status Register	LVD2SR	8	8	3 ICLK
0008 03FEh	SYSTEM	Protect Register	PRCR	16	16	3 ICLK
0008 1300h	BSC	Bus Error Status Clear Register	BERCLR	8	8	2 ICLK
0008 1304h	BSC	Bus Error Monitoring Enable Register	BEREN	8	8	2 ICLK
0008 1308h	BSC	Bus Error Status Register 1	BERSR1	8	8	2 ICLK
0008 130Ah	BSC	Bus Error Status Register 2	BERSR2	16	16	2 ICLK
0008 1310h	BSC	Bus Priority Control Register	BUSPRI	16	16	2 ICLK
0008 2400h	DTC	DTC Control Register	DTCCR	8	8	2 ICLK
0008 2404h	DTC	DTC Vector Base Register	DTCVBR	32	32	2 ICLK
0008 2408h	DTC	DTC Address Mode Register	DTCADMOD	8	8	2 ICLK
0008 240Ch	DTC	DTC Module Start Register	DTCST	8	8	2 ICLK
0008 240Eh	DTC	DTC Status Register	DTCSTS	16	16	2 ICLK
0008 7010h	ICU	Interrupt Request Register 016	IR016	8	8	2 ICLK
0008 701Bh	ICU	Interrupt Request Register 027	IR027	8	8	2 ICLK
0008 701Ch	ICU	Interrupt Request Register 028	IR028	8	8	2 ICLK
0008 701Dh	ICU	Interrupt Request Register 029	IR029	8	8	2 ICLK
0008 7020h	ICU	Interrupt Request Register 032	IR032	8	8	2 ICLK
0008 7021h	ICU	Interrupt Request Register 033	IR033	8	8	2 ICLK
0008 7022h	ICU	Interrupt Request Register 034	IR034	8	8	2 ICLK
0008 7024h	ICU	Interrupt Request Register 036	IR036	8	8	2 ICLK
0008 7025h	ICU	Interrupt Request Register 037	IR037	8	8	2 ICLK

Table 4.1 List of I/O Registers (Address Order) (2/16)

Address	Module Symbol	Register Name	Register Symbol	Number of Bits	Access Size	Number of Access States
0008 7026h	ICU	Interrupt Request Register 038	IR038	8	8	2 ICLK
0008 702Ch	ICU	Interrupt Request Register 044	IR044	8	8	2 ICLK
0008 702Dh	ICU	Interrupt Request Register 045	IR045	8	8	2 ICLK
0008 702Eh	ICU	Interrupt Request Register 046	IR046	8	8	2 ICLK
0008 702Fh	ICU	Interrupt Request Register 047	IR047	8	8	2 ICLK
0008 7039h	ICU	Interrupt Request Register 057	IR057	8	8	2 ICLK
0008 703Fh	ICU	Interrupt Request Register 063	IR063	8	8	2 ICLK
0008 7040h	ICU	Interrupt Request Register 064	IR064	8	8	2 ICLK
0008 7041h	ICU	Interrupt Request Register 065	IR065	8	8	2 ICLK
0008 7042h	ICU	Interrupt Request Register 066	IR066	8	8	2 ICLK
0008 7043h	ICU	Interrupt Request Register 067	IR067	8	8	2 ICLK
0008 7044h	ICU	Interrupt Request Register 068	IR068	8	8	2 ICLK
0008 7045h	ICU	Interrupt Request Register 069	IR069	8	8	2 ICLK
0008 7046h	ICU	Interrupt Request Register 070	IR070	8	8	2 ICLK
0008 7047h	ICU	Interrupt Request Register 071	IR071	8	8	2 ICLK
0008 7058h	ICU	Interrupt Request Register 088	IR088	8	8	2 ICLK
0008 7059h	ICU	Interrupt Request Register 089	IR089	8	8	2 ICLK
0008 705Ah	ICU	Interrupt Request Register 090	IR090	8	8	2 ICLK
0008 705Ch	ICU	Interrupt Request Register 092	IR092	8	8	2 ICLK
0008 705Dh	ICU	Interrupt Request Register 093	IR093	8	8	2 ICLK
0008 7066h	ICU	Interrupt Request Register 102	IR102	8	8	2 ICLK
0008 7067h	ICU	Interrupt Request Register 103	IR103	8	8	2 ICLK
0008 706Ah	ICU	Interrupt Request Register 106	IR106	8	8	2 ICLK
0008 7072h	ICU	Interrupt Request Register 114	IR114	8	8	2 ICLK
0008 7073h	ICU	Interrupt Request Register 115	IR115	8	8	2 ICLK
0008 7074h	ICU	Interrupt Request Register 116	IR116	8	8	2 ICLK
0008 7075h	ICU	Interrupt Request Register 117	IR117	8	8	2 ICLK
0008 7076h	ICU	Interrupt Request Register 118	IR118	8	8	2 ICLK
0008 7077h	ICU	Interrupt Request Register 119	IR119	8	8	2 ICLK
0008 7078h	ICU	Interrupt Request Register 120	IR120	8	8	2 ICLK
0008 7079h	ICU	Interrupt Request Register 121	IR121	8	8	2 ICLK
0008 707Ah	ICU	Interrupt Request Register 122	IR122	8	8	2 ICLK
0008 707Bh	ICU	Interrupt Request Register 123	IR123	8	8	2 ICLK
0008 707Ch	ICU	Interrupt Request Register 124	IR124	8	8	2 ICLK
0008 707Dh	ICU	Interrupt Request Register 125	IR125	8	8	2 ICLK
0008 707Eh	ICU	Interrupt Request Register 126	IR126	8	8	2 ICLK
0008 707Fh	ICU	Interrupt Request Register 127	IR127	8	8	2 ICLK
0008 7080h	ICU	Interrupt Request Register 128	IR128	8	8	2 ICLK
0008 7081h	ICU	Interrupt Request Register 129	IR129	8	8	2 ICLK
0008 7082h	ICU	Interrupt Request Register 130	IR130	8	8	2 ICLK
0008 7083h	ICU	Interrupt Request Register 131	IR131	8	8	2 ICLK
0008 7084h	ICU	Interrupt Request Register 132	IR132	8	8	2 ICLK
0008 7085h	ICU	Interrupt Request Register 133	IR133	8	8	2 ICLK
0008 7086h	ICU	Interrupt Request Register 134	IR134	8	8	2 ICLK
0008 7087h	ICU	Interrupt Request Register 135	IR135	8	8	2 ICLK
0008 7088h	ICU	Interrupt Request Register 136	IR136	8	8	2 ICLK
0008 7089h	ICU	Interrupt Request Register 137	IR137	8	8	2 ICLK
0008 708Ah	ICU	Interrupt Request Register 138	IR138	8	8	2 ICLK
0008 708Bh	ICU	Interrupt Request Register 139	IR139	8	8	2 ICLK
0008 708Ch	ICU	Interrupt Request Register 140	IR140	8	8	2 ICLK
0008 708Dh	ICU	Interrupt Request Register 141	IR141	8	8	2 ICLK
0008 70AAh	ICU	Interrupt Request Register 170	IR170	8	8	2 ICLK

Table 4.1 List of I/O Registers (Address Order) (3/16)

Address	Module Symbol	Register Name	Register Symbol	Number of Bits	Access Size	Number of Access States
0008 70ABh	ICU	Interrupt Request Register 171	IR171	8	8	2 ICLK
0008 70DAh	ICU	Interrupt Request Register 218	IR218	8	8	2 ICLK
0008 70DBh	ICU	Interrupt Request Register 219	IR219	8	8	2 ICLK
0008 70DCh	ICU	Interrupt Request Register 220	IR220	8	8	2 ICLK
0008 70DDh	ICU	Interrupt Request Register 221	IR221	8	8	2 ICLK
0008 70DEh	ICU	Interrupt Request Register 222	IR222	8	8	2 ICLK
0008 70DFh	ICU	Interrupt Request Register 223	IR223	8	8	2 ICLK
0008 70E0h	ICU	Interrupt Request Register 224	IR224	8	8	2 ICLK
0008 70E1h	ICU	Interrupt Request Register 225	IR225	8	8	2 ICLK
0008 70EEh	ICU	Interrupt Request Register 238	IR238	8	8	2 ICLK
0008 70EFh	ICU	Interrupt Request Register 239	IR239	8	8	2 ICLK
0008 70F0h	ICU	Interrupt Request Register 240	IR240	8	8	2 ICLK
0008 70F1h	ICU	Interrupt Request Register 241	IR241	8	8	2 ICLK
0008 70F2h	ICU	Interrupt Request Register 242	IR242	8	8	2 ICLK
0008 70F3h	ICU	Interrupt Request Register 243	IR243	8	8	2 ICLK
0008 70F4h	ICU	Interrupt Request Register 244	IR244	8	8	2 ICLK
0008 70F5h	ICU	Interrupt Request Register 245	IR245	8	8	2 ICLK
0008 70F6h	ICU	Interrupt Request Register 246	IR246	8	8	2 ICLK
0008 70F7h	ICU	Interrupt Request Register 247	IR247	8	8	2 ICLK
0008 70F8h	ICU	Interrupt Request Register 248	IR248	8	8	2 ICLK
0008 70F9h	ICU	Interrupt Request Register 249	IR249	8	8	2 ICLK
0008 711Bh	ICU	DTC Activation Enable Register 027	DTCER027	8	8	2 ICLK
0008 711Ch	ICU	DTC Activation Enable Register 028	DTCER028	8	8	2 ICLK
0008 711Dh	ICU	DTC Activation Enable Register 029	DTCER029	8	8	2 ICLK
0008 7124h	ICU	DTC Activation Enable Register 036	DTCER036	8	8	2 ICLK
0008 7125h	ICU	DTC Activation Enable Register 037	DTCER037	8	8	2 ICLK
0008 712Dh	ICU	DTC Activation Enable Register 045	DTCER045	8	8	2 ICLK
0008 712Eh	ICU	DTC Activation Enable Register 046	DTCER046	8	8	2 ICLK
0008 7140h	ICU	DTC Activation Enable Register 064	DTCER064	8	8	2 ICLK
0008 7141h	ICU	DTC Activation Enable Register 065	DTCER065	8	8	2 ICLK
0008 7142h	ICU	DTC Activation Enable Register 066	DTCER066	8	8	2 ICLK
0008 7143h	ICU	DTC Activation Enable Register 067	DTCER067	8	8	2 ICLK
0008 7144h	ICU	DTC Activation Enable Register 068	DTCER068	8	8	2 ICLK
0008 7145h	ICU	DTC Activation Enable Register 069	DTCER069	8	8	2 ICLK
0008 7146h	ICU	DTC Activation Enable Register 070	DTCER070	8	8	2 ICLK
0008 7147h	ICU	DTC Activation Enable Register 071	DTCER071	8	8	2 ICLK
0008 7166h	ICU	DTC Activation Enable Register 102	DTCER102	8	8	2 ICLK
0008 7167h	ICU	DTC Activation Enable Register 103	DTCER103	8	8	2 ICLK
0008 716Ah	ICU	DTC Activation Enable Register 106	DTCER106	8	8	2 ICLK
0008 7172h	ICU	DTC Activation Enable Register 114	DTCER114	8	8	2 ICLK
0008 7173h	ICU	DTC Activation Enable Register 115	DTCER115	8	8	2 ICLK
0008 7174h	ICU	DTC Activation Enable Register 116	DTCER116	8	8	2 ICLK
0008 7175h	ICU	DTC Activation Enable Register 117	DTCER117	8	8	2 ICLK
0008 7179h	ICU	DTC Activation Enable Register 121	DTCER121	8	8	2 ICLK
0008 717Ah	ICU	DTC Activation Enable Register 122	DTCER122	8	8	2 ICLK
0008 717Dh	ICU	DTC Activation Enable Register 125	DTCER125	8	8	2 ICLK
0008 717Eh	ICU	DTC Activation Enable Register 126	DTCER126	8	8	2 ICLK
0008 7181h	ICU	DTC Activation Enable Register 129	DTCER129	8	8	2 ICLK
0008 7182h	ICU	DTC Activation Enable Register 130	DTCER130	8	8	2 ICLK
0008 7183h	ICU	DTC Activation Enable Register 131	DTCER131	8	8	2 ICLK
0008 7184h	ICU	DTC Activation Enable Register 132	DTCER132	8	8	2 ICLK
0008 7186h	ICU	DTC Activation Enable Register 134	DTCER134	8	8	2 ICLK

Table 4.1 List of I/O Registers (Address Order) (4/16)

Address	Module Symbol	Register Name	Register Symbol	Number of Bits	Access Size	Number of Access States
0008 7187h	ICU	DTC Activation Enable Register 135	DTCER135	8	8	2 ICLK
0008 7188h	ICU	DTC Activation Enable Register 136	DTCER136	8	8	2 ICLK
0008 7189h	ICU	DTC Activation Enable Register 137	DTCER137	8	8	2 ICLK
0008 718Ah	ICU	DTC Activation Enable Register 138	DTCER138	8	8	2 ICLK
0008 718Bh	ICU	DTC Activation Enable Register 139	DTCER139	8	8	2 ICLK
0008 718Ch	ICU	DTC Activation Enable Register 140	DTCER140	8	8	2 ICLK
0008 718Dh	ICU	DTC Activation Enable Register 141	DTCER141	8	8	2 ICLK
0008 71DBh	ICU	DTC Activation Enable Register 219	DTCER219	8	8	2 ICLK
0008 71DCh	ICU	DTC Activation Enable Register 220	DTCER220	8	8	2 ICLK
0008 71DFh	ICU	DTC Activation Enable Register 223	DTCER223	8	8	2 ICLK
0008 71E0h	ICU	DTC Activation Enable Register 224	DTCER224	8	8	2 ICLK
0008 71EFh	ICU	DTC Activation Enable Register 239	DTCER239	8	8	2 ICLK
0008 71F0h	ICU	DTC Activation Enable Register 240	DTCER240	8	8	2 ICLK
0008 71F7h	ICU	DTC Activation Enable Register 247	DTCER247	8	8	2 ICLK
0008 71F8h	ICU	DTC Activation Enable Register 248	DTCER248	8	8	2 ICLK
0008 7202h	ICU	Interrupt Request Enable Register 02	IER02	8	8	2 ICLK
0008 7203h	ICU	Interrupt Request Enable Register 03	IER03	8	8	2 ICLK
0008 7204h	ICU	Interrupt Request Enable Register 04	IER04	8	8	2 ICLK
0008 7205h	ICU	Interrupt Request Enable Register 05	IER05	8	8	2 ICLK
0008 7207h	ICU	Interrupt Request Enable Register 07	IER07	8	8	2 ICLK
0008 7208h	ICU	Interrupt Request Enable Register 08	IER08	8	8	2 ICLK
0008 720Bh	ICU	Interrupt Request Enable Register 0B	IER0B	8	8	2 ICLK
0008 720Ch	ICU	Interrupt Request Enable Register 0C	IER0C	8	8	2 ICLK
0008 720Dh	ICU	Interrupt Request Enable Register 0D	IER0D	8	8	2 ICLK
0008 720Eh	ICU	Interrupt Request Enable Register 0E	IER0E	8	8	2 ICLK
0008 720Fh	ICU	Interrupt Request Enable Register 0F	IER0F	8	8	2 ICLK
0008 7210h	ICU	Interrupt Request Enable Register 10	IER10	8	8	2 ICLK
0008 7211h	ICU	Interrupt Request Enable Register 11	IER11	8	8	2 ICLK
0008 7215h	ICU	Interrupt Request Enable Register 15	IER15	8	8	2 ICLK
0008 721Bh	ICU	Interrupt Request Enable Register 1B	IER1B	8	8	2 ICLK
0008 721Ch	ICU	Interrupt Request Enable Register 1C	IER1C	8	8	2 ICLK
0008 721Dh	ICU	Interrupt Request Enable Register 1D	IER1D	8	8	2 ICLK
0008 721Eh	ICU	Interrupt Request Enable Register 1E	IER1E	8	8	2 ICLK
0008 721Fh	ICU	Interrupt Request Enable Register 1F	IER1F	8	8	2 ICLK
0008 72E0h	ICU	Software Interrupt Activation Register	SWINTR	8	8	2 ICLK
0008 72F0h	ICU	Fast Interrupt Set Register	FIR	16	16	2 ICLK
0008 7300h	ICU	Interrupt Source Priority Register 000	IPR000	8	8	2 ICLK
0008 7303h	ICU	Interrupt Source Priority Register 003	IPR003	8	8	2 ICLK
0008 7304h	ICU	Interrupt Source Priority Register 004	IPR004	8	8	2 ICLK
0008 7305h	ICU	Interrupt Source Priority Register 005	IPR005	8	8	2 ICLK
0008 7320h	ICU	Interrupt Source Priority Register 032	IPR032	8	8	2 ICLK
0008 7321h	ICU	Interrupt Source Priority Register 033	IPR033	8	8	2 ICLK
0008 7322h	ICU	Interrupt Source Priority Register 034	IPR034	8	8	2 ICLK
0008 7324h	ICU	Interrupt Source Priority Register 036	IPR036	8	8	2 ICLK
0008 7325h	ICU	Interrupt Source Priority Register 037	IPR037	8	8	2 ICLK
0008 7326h	ICU	Interrupt Source Priority Register 038	IPR038	8	8	2 ICLK
0008 732Ch	ICU	Interrupt Source Priority Register 044	IPR044	8	8	2 ICLK
0008 7339h	ICU	Interrupt Source Priority Register 057	IPR057	8	8	2 ICLK
0008 733Fh	ICU	Interrupt Source Priority Register 063	IPR063	8	8	2 ICLK
0008 7340h	ICU	Interrupt Source Priority Register 064	IPR064	8	8	2 ICLK
0008 7341h	ICU	Interrupt Source Priority Register 065	IPR065	8	8	2 ICLK
0008 7342h	ICU	Interrupt Source Priority Register 066	IPR066	8	8	2 ICLK

Table 4.1 List of I/O Registers (Address Order) (5/16)

Address	Module Symbol	Register Name	Register Symbol	Number of Bits	Access Size	Number of Access States
0008 7343h	ICU	Interrupt Source Priority Register 067	IPR067	8	8	2 ICLK
0008 7344h	ICU	Interrupt Source Priority Register 068	IPR068	8	8	2 ICLK
0008 7345h	ICU	Interrupt Source Priority Register 069	IPR069	8	8	2 ICLK
0008 7346h	ICU	Interrupt Source Priority Register 070	IPR070	8	8	2 ICLK
0008 7347h	ICU	Interrupt Source Priority Register 071	IPR071	8	8	2 ICLK
0008 7358h	ICU	Interrupt Source Priority Register 088	IPR088	8	8	2 ICLK
0008 7359h	ICU	Interrupt Source Priority Register 089	IPR089	8	8	2 ICLK
0008 735Ah	ICU	Interrupt Source Priority Register 090	IPR090	8	8	2 ICLK
0008 735Ch	ICU	Interrupt Source Priority Register 092	IPR092	8	8	2 ICLK
0008 735Dh	ICU	Interrupt Source Priority Register 093	IPR093	8	8	2 ICLK
0008 7366h	ICU	Interrupt Source Priority Register 102	IPR102	8	8	2 ICLK
0008 7367h	ICU	Interrupt Source Priority Register 103	IPR103	8	8	2 ICLK
0008 736Ah	ICU	Interrupt Source Priority Register 106	IPR106	8	8	2 ICLK
0008 7372h	ICU	Interrupt Source Priority Register 114	IPR114	8	8	2 ICLK
0008 7376h	ICU	Interrupt Source Priority Register 118	IPR118	8	8	2 ICLK
0008 7379h	ICU	Interrupt Source Priority Register 121	IPR121	8	8	2 ICLK
0008 737Bh	ICU	Interrupt Source Priority Register 123	IPR123	8	8	2 ICLK
0008 737Dh	ICU	Interrupt Source Priority Register 125	IPR125	8	8	2 ICLK
0008 737Fh	ICU	Interrupt Source Priority Register 127	IPR127	8	8	2 ICLK
0008 7381h	ICU	Interrupt Source Priority Register 129	IPR129	8	8	2 ICLK
0008 7385h	ICU	Interrupt Source Priority Register 133	IPR133	8	8	2 ICLK
0008 7386h	ICU	Interrupt Source Priority Register 134	IPR134	8	8	2 ICLK
0008 738Ah	ICU	Interrupt Source Priority Register 138	IPR138	8	8	2 ICLK
0008 738Bh	ICU	Interrupt Source Priority Register 139	IPR139	8	8	2 ICLK
0008 73AAh	ICU	Interrupt Source Priority Register 170	IPR170	8	8	2 ICLK
0008 73ABh	ICU	Interrupt Source Priority Register 171	IPR171	8	8	2 ICLK
0008 73DAh	ICU	Interrupt Source Priority Register 218	IPR218	8	8	2 ICLK
0008 73DEh	ICU	Interrupt Source Priority Register 222	IPR222	8	8	2 ICLK
0008 73EEh	ICU	Interrupt Source Priority Register 238	IPR238	8	8	2 ICLK
0008 73F2h	ICU	Interrupt Source Priority Register 242	IPR242	8	8	2 ICLK
0008 73F3h	ICU	Interrupt Source Priority Register 243	IPR243	8	8	2 ICLK
0008 73F4h	ICU	Interrupt Source Priority Register 244	IPR244	8	8	2 ICLK
0008 73F5h	ICU	Interrupt Source Priority Register 245	IPR245	8	8	2 ICLK
0008 73F6h	ICU	Interrupt Source Priority Register 246	IPR246	8	8	2 ICLK
0008 73F7h	ICU	Interrupt Source Priority Register 247	IPR247	8	8	2 ICLK
0008 73F8h	ICU	Interrupt Source Priority Register 248	IPR248	8	8	2 ICLK
0008 73F9h	ICU	Interrupt Source Priority Register 249	IPR249	8	8	2 ICLK
0008 7500h	ICU	IRQ Control Register 0	IRQCR0	8	8	2 ICLK
0008 7501h	ICU	IRQ Control Register 1	IRQCR1	8	8	2 ICLK
0008 7502h	ICU	IRQ Control Register 2	IRQCR2	8	8	2 ICLK
0008 7503h	ICU	IRQ Control Register 3	IRQCR3	8	8	2 ICLK
0008 7504h	ICU	IRQ Control Register 4	IRQCR4	8	8	2 ICLK
0008 7505h	ICU	IRQ Control Register 5	IRQCR5	8	8	2 ICLK
0008 7506h	ICU	IRQ Control Register 6	IRQCR6	8	8	2 ICLK
0008 7507h	ICU	IRQ Control Register 7	IRQCR7	8	8	2 ICLK
0008 7510h	ICU	IRQ Pin Digital Filter Enable Register 0	IRQFLTE0	8	8	2 ICLK
0008 7514h	ICU	IRQ Pin Digital Filter Setting Register 0	IRQFLTC0	16	16	2 ICLK
0008 7580h	ICU	Non-Maskable Interrupt Status Register	NMISR	8	8	2 ICLK
0008 7581h	ICU	Non-Maskable Interrupt Enable Register	NMIER	8	8	2 ICLK
0008 7582h	ICU	Non-Maskable Interrupt Status Clear Register	NMICLR	8	8	2 ICLK
0008 7583h	ICU	NMI Pin Interrupt Control Register	NMICR	8	8	2 ICLK
0008 7590h	ICU	NMI Pin Digital Filter Enable Register	NMIFLTE	8	8	2 ICLK

Table 4.1 List of I/O Registers (Address Order) (6/16)

Address	Module Symbol	Register Name	Register Symbol	Number of Bits	Access Size	Number of Access States
0008 7594h	ICU	NMI Pin Digital Filter Setting Register	NMIFLTC	8	8	2 ICLK
0008 8000h	CMT	Compare Match Timer Start Register 0	CMSTR0	16	16	2 or 3 PCLKB
0008 8002h	CMT0	Compare Match Timer Control Register	CMCR	16	16	2 or 3 PCLKB
0008 8004h	CMT0	Compare Match Timer Counter	CMCNT	16	16	2 or 3 PCLKB
0008 8006h	CMT0	Compare Match Timer Constant Register	CMCOR	16	16	2 or 3 PCLKB
0008 8008h	CMT1	Compare Match Timer Control Register	CMCR	16	16	2 or 3 PCLKB
0008 800Ah	CMT1	Compare Match Timer Counter	CMCNT	16	16	2 or 3 PCLKB
0008 800Ch	CMT1	Compare Match Timer Constant Register	CMCOR	16	16	2 or 3 PCLKB
0008 8030h	IWDT	IWDT Refresh Register	IWDTRR	8	8	2 or 3 PCLKB
0008 8032h	IWDT	IWDT Control Register	IWDTCR	16	16	2 or 3 PCLKB
0008 8034h	IWDT	IWDT Status Register	IWDTSR	16	16	2 or 3 PCLKB
0008 8036h	IWDT	IWDT Reset Control Register	IWDTRCR	8	8	2 or 3 PCLKB
0008 8038h	IWDT	IWDT Count Stop Control Register	IWDTCSTPR	8	8	2 or 3 PCLKB
0008 80C0h	DA	D/A Data Register 0	DADR0	16	16	2 or 3 PCLKB
0008 80C2h	DA	D/A Data Register 1	DADR1	16	16	2 or 3 PCLKB
0008 80C4h	DA	D/A Control Register	DACR	8	8	2 or 3 PCLKB
0008 80C5h	DA	DADRM Format Select Register	DADPR	8	8	2 or 3 PCLKB
0008 8280h	CRC	CRC Control Register	CRCCR	8	8	2 or 3 PCLKB
0008 8281h	CRC	CRC Data Input Register	CRCDIR	8	8	2 or 3 PCLKB
0008 8282h	CRC	CRC Data Output Register	CRCDOR	16	16	2 or 3 PCLKB
0008 8300h	RIIC0	I ² C Bus Control Register 1	ICCR1	8	8	2 or 3 PCLKB
0008 8301h	RIIC0	I ² C Bus Control Register 2	ICCR2	8	8	2 or 3 PCLKB
0008 8302h	RIIC0	I ² C Bus Mode Register 1	ICMR1	8	8	2 or 3 PCLKB
0008 8303h	RIIC0	I ² C Bus Mode Register 2	ICMR2	8	8	2 or 3 PCLKB
0008 8304h	RIIC0	I ² C Bus Mode Register 3	ICMR3	8	8	2 or 3 PCLKB
0008 8305h	RIIC0	I ² C Bus Function Enable Register	ICFER	8	8	2 or 3 PCLKB
0008 8306h	RIIC0	I ² C Bus Status Enable Register	ICSER	8	8	2 or 3 PCLKB
0008 8307h	RIIC0	I ² C Bus Interrupt Enable Register	ICIER	8	8	2 or 3 PCLKB
0008 8308h	RIIC0	I ² C Bus Status Register 1	ICSR1	8	8	2 or 3 PCLKB
0008 8309h	RIIC0	I ² C Bus Status Register 2	ICSR2	8	8	2 or 3 PCLKB
0008 830Ah	RIIC0	Slave Address Register L0	SARL0	8	8	2 or 3 PCLKB
0008 830Ah	RIIC0	Timeout Internal Counter L	TMOCNTL	8	8	2 or 3 PCLKB
0008 830Bh	RIIC0	Slave Address Register U0	SARU0	8	8	2 or 3 PCLKB
0008 830Bh	RIIC0	Timeout Internal Counter U	TMOCNTU	8	8 *1	2 or 3 PCLKB
0008 830Ch	RIIC0	Slave Address Register L1	SARL1	8	8	2 or 3 PCLKB
0008 830Dh	RIIC0	Slave Address Register U1	SARU1	8	8	2 or 3 PCLKB
0008 830Eh	RIIC0	Slave Address Register L2	SARL2	8	8	2 or 3 PCLKB
0008 830Fh	RIIC0	Slave Address Register U2	SARU2	8	8	2 or 3 PCLKB
0008 8310h	RIIC0	I ² C Bus Bit Rate Low-Level Register	ICBRL	8	8	2 or 3 PCLKB
0008 8311h	RIIC0	I ² C Bus Bit Rate High-Level Register	ICBRH	8	8	2 or 3 PCLKB
0008 8312h	RIIC0	I ² C Bus Transmit Data Register	ICDRT	8	8	2 or 3 PCLKB
0008 8313h	RIIC0	I ² C Bus Receive Data Register	ICDRR	8	8	2 or 3 PCLKB
0008 8380h	RSPI0	RSPI Control Register	SPCR	8	8	2 or 3 PCLKB
0008 8381h	RSPI0	RSPI Slave Select Polarity Register	SSLP	8	8	2 or 3 PCLKB
0008 8382h	RSPI0	RSPI Pin Control Register	SPPCR	8	8	2 or 3 PCLKB
0008 8383h	RSPI0	RSPI Status Register	SPSR	8	8	2 or 3 PCLKB
0008 8384h	RSPI0	RSPI Data Register	SPDR	32	16, 32	2 or 3 PCLKB/2ICLK
0008 8388h	RSPI0	RSPI Sequence Control Register	SPSCR	8	8	2 or 3 PCLKB
0008 8389h	RSPI0	RSPI Sequence Status Register	SPSSR	8	8	2 or 3 PCLKB
0008 838Ah	RSPI0	RSPI Bit Rate Register	SPBR	8	8	2 or 3 PCLKB
0008 838Bh	RSPI0	RSPI Data Control Register	SPDCR	8	8	2 or 3 PCLKB
0008 838Ch	RSPI0	RSPI Clock Delay Register	SPCKD	8	8	2 or 3 PCLKB

Table 4.1 List of I/O Registers (Address Order) (7/16)

Address	Module Symbol	Register Name	Register Symbol	Number of Bits	Access Size	Number of Access States
0008 838Dh	RSPI0	RSPI Slave Select Negation Delay Register	SSLND	8	8	2 or 3 PCLKB
0008 838Eh	RSPI0	RSPI Next-Access Delay Register	SPND	8	8	2 or 3 PCLKB
0008 838Fh	RSPI0	RSPI Control Register 2	SPCR2	8	8	2 or 3 PCLKB
0008 8390h	RSPI0	RSPI Command Register 0	SPCMD0	16	16	2 or 3 PCLKB
0008 8392h	RSPI0	RSPI Command Register 1	SPCMD1	16	16	2 or 3 PCLKB
0008 8394h	RSPI0	RSPI Command Register 2	SPCMD2	16	16	2 or 3 PCLKB
0008 8396h	RSPI0	RSPI Command Register 3	SPCMD3	16	16	2 or 3 PCLKB
0008 8398h	RSPI0	RSPI Command Register 4	SPCMD4	16	16	2 or 3 PCLKB
0008 839Ah	RSPI0	RSPI Command Register 5	SPCMD5	16	16	2 or 3 PCLKB
0008 839Ch	RSPI0	RSPI Command Register 6	SPCMD6	16	16	2 or 3 PCLKB
0008 839Eh	RSPI0	RSPI Command Register 7	SPCMD7	16	16	2 or 3 PCLKB
0008 8600h	MTU3	Timer Control Register	TCR	8	8	2 or 3 PCLKB
0008 8601h	MTU4	Timer Control Register	TCR	8	8	2 or 3 PCLKB
0008 8602h	MTU3	Timer Mode Register	TMDR	8	8	2 or 3 PCLKB
0008 8603h	MTU4	Timer Mode Register	TMDR	8	8	2 or 3 PCLKB
0008 8604h	MTU3	Timer I/O Control Register H	TIORH	8	8	2 or 3 PCLKB
0008 8605h	MTU3	Timer I/O Control Register L	TIORL	8	8	2 or 3 PCLKB
0008 8606h	MTU4	Timer I/O Control Register H	TIORH	8	8	2 or 3 PCLKB
0008 8607h	MTU4	Timer I/O Control Register L	TIORL	8	8	2 or 3 PCLKB
0008 8608h	MTU3	Timer Interrupt Enable Register	TIER	8	8	2 or 3 PCLKB
0008 8609h	MTU4	Timer Interrupt Enable Register	TIER	8	8	2 or 3 PCLKB
0008 860Ah	MTU	Timer Output Master Enable Register	TOER	8	8	2 or 3 PCLKB
0008 860Dh	MTU	Timer Gate Control Register	TGCR	8	8	2 or 3 PCLKB
0008 860Eh	MTU	Timer Output Control Register 1	TOCR1	8	8	2 or 3 PCLKB
0008 860Fh	MTU	Timer Output Control Register 2	TOCR2	8	8	2 or 3 PCLKB
0008 8610h	MTU3	Timer Counter	TCNT	16	16	2 or 3 PCLKB
0008 8612h	MTU4	Timer Counter	TCNT	16	16	2 or 3 PCLKB
0008 8614h	MTU	Timer Cycle Data Register	TCDR	16	16	2 or 3 PCLKB
0008 8616h	MTU	Timer Dead Time Data Register	TDDR	16	16	2 or 3 PCLKB
0008 8618h	MTU3	Timer General Register A	TGRA	16	16	2 or 3 PCLKB
0008 861Ah	MTU3	Timer General Register B	TGRB	16	16	2 or 3 PCLKB
0008 861Ch	MTU4	Timer General Register A	TGRA	16	16	2 or 3 PCLKB
0008 861Eh	MTU4	Timer General Register B	TGRB	16	16	2 or 3 PCLKB
0008 8620h	MTU	Timer Subcounter	TCNTS	16	16	2 or 3 PCLKB
0008 8622h	MTU	Timer Cycle Buffer Register	TCBR	16	16	2 or 3 PCLKB
0008 8624h	MTU3	Timer General Register C	TGRC	16	16	2 or 3 PCLKB
0008 8626h	MTU3	Timer General Register D	TGRD	16	16	2 or 3 PCLKB
0008 8628h	MTU4	Timer General Register C	TGRC	16	16	2 or 3 PCLKB
0008 862Ah	MTU4	Timer General Register D	TGRD	16	16	2 or 3 PCLKB
0008 862Ch	MTU3	Timer Status Register	TSR	8	8	2 or 3 PCLKB
0008 862Dh	MTU4	Timer Status Register	TSR	8	8	2 or 3 PCLKB
0008 8630h	MTU	Timer Interrupt Skipping Set Register	TITCR	8	8	2 or 3 PCLKB
0008 8631h	MTU	Timer Interrupt Skipping Counter	TITCNT	8	8	2 or 3 PCLKB
0008 8632h	MTU	Timer Buffer Transfer Set Register	TBTER	8	8	2 or 3 PCLKB
0008 8634h	MTU	Timer Dead Time Enable Register	TDER	8	8	2 or 3 PCLKB
0008 8636h	MTU	Timer Output Level Buffer Register	TOLBR	8	8	2 or 3 PCLKB
0008 8638h	MTU3	Timer Buffer Operation Transfer Mode Register	TBTM	8	8	2 or 3 PCLKB
0008 8639h	MTU4	Timer Buffer Operation Transfer Mode Register	TBTM	8	8	2 or 3 PCLKB
0008 8640h	MTU4	Timer A/D Converter Start Request Control Register	TADCR	16	16	2 or 3 PCLKB
0008 8644h	MTU4	Timer A/D Converter Start Request Cycle Set Register A	TADCORA	16	16	2 or 3 PCLKB
0008 8646h	MTU4	Timer A/D Converter Start Request Cycle Set Register B	TADCORB	16	16	2 or 3 PCLKB
0008 8648h	MTU4	Timer A/D Converter Start Request Cycle Set Buffer Register A	TADCOBRA	16	16	2 or 3 PCLKB

Table 4.1 List of I/O Registers (Address Order) (8/16)

Address	Module Symbol	Register Name	Register Symbol	Number of Bits	Access Size	Number of Access States
0008 864Ah	MTU4	Timer A/D Converter Start Request Cycle Set Buffer Register B	TADCOBRB	16	16	2 or 3 PCLKB
0008 8660h	MTU	Timer Waveform Control Register	TWCR	8	8, 16	2 or 3 PCLKB
0008 8680h	MTU	Timer Start Register	TSTR	8	8, 16	2 or 3 PCLKB
0008 8681h	MTU	Timer Synchronous Register	TSYR	8	8, 16	2 or 3 PCLKB
0008 8684h	MTU	Timer Read/Write Enable Register	TRWER	8	8, 16	2 or 3 PCLKB
0008 8690h	MTU0	Noise Filter Control Register	NFCR	8	8, 16	2 or 3 PCLKB
0008 8691h	MTU1	Noise Filter Control Register	NFCR	8	8, 16	2 or 3 PCLKB
0008 8692h	MTU2	Noise Filter Control Register	NFCR	8	8, 16	2 or 3 PCLKB
0008 8693h	MTU3	Noise Filter Control Register	NFCR	8	8, 16	2 or 3 PCLKB
0008 8694h	MTU4	Noise Filter Control Register	NFCR	8	8, 16	2 or 3 PCLKB
0008 8695h	MTU5	Noise Filter Control Register	NFCR	8	8, 16	2 or 3 PCLKB
0008 8700h	MTU0	Timer Control Register	TCR	8	8	2 or 3 PCLKB
0008 8701h	MTU0	Timer Mode Register	TMDR	8	8	2 or 3 PCLKB
0008 8702h	MTU0	Timer I/O Register H	TIORH	8	8	2 or 3 PCLKB
0008 8703h	MTU0	Timer I/O Control Register L	TIORL	8	8	2 or 3 PCLKB
0008 8704h	MTU0	Timer Interrupt Enable Register	TIER	8	8	2 or 3 PCLKB
0008 8705h	MTU0	Timer Status Register	TSR	8	8	2 or 3 PCLKB
0008 8706h	MTU0	Timer Counter	TCNT	16	16	2 or 3 PCLKB
0008 8708h	MTU0	Timer General Register A	TGRA	16	16	2 or 3 PCLKB
0008 870Ah	MTU0	Timer General Register B	TGRB	16	16	2 or 3 PCLKB
0008 870Ch	MTU0	Timer General Register C	TGRC	16	16	2 or 3 PCLKB
0008 870Eh	MTU0	Timer General Register D	TGRD	16	16	2 or 3 PCLKB
0008 8720h	MTU0	Timer General Register E	TGRE	16	16	2 or 3 PCLKB
0008 8722h	MTU0	Timer General Register F	TGRF	16	16	2 or 3 PCLKB
0008 8724h	MTU0	Timer Interrupt Enable Register 2	TIER2	8	8	2 or 3 PCLKB
0008 8726h	MTU0	Timer Buffer Operation Transfer Mode Register	TBTM	8	8	2 or 3 PCLKB
0008 8780h	MTU1	Timer Control Register	TCR	8	8	2 or 3 PCLKB
0008 8781h	MTU1	Timer Mode Register	TMDR	8	8	2 or 3 PCLKB
0008 8782h	MTU1	Timer I/O Control Register	TIOR	8	8	2 or 3 PCLKB
0008 8784h	MTU1	Timer Interrupt Enable Register	TIER	8	8	2 or 3 PCLKB
0008 8785h	MTU1	Timer Status Register	TSR	8	8	2 or 3 PCLKB
0008 8786h	MTU1	Timer Counter	TCNT	16	16	2 or 3 PCLKB
0008 8788h	MTU1	Timer General Register A	TGRA	16	16	2 or 3 PCLKB
0008 878Ah	MTU1	Timer General Register B	TGRB	16	16	2 or 3 PCLKB
0008 8790h	MTU1	Timer Input Capture Control Register	TICCR	8	8	2 or 3 PCLKB
0008 8800h	MTU2	Timer Control Register	TCR	8	8	2 or 3 PCLKB
0008 8801h	MTU2	Timer Mode Register	TMDR	8	8	2 or 3 PCLKB
0008 8802h	MTU2	Timer I/O Control Register	TIOR	8	8	2 or 3 PCLKB
0008 8804h	MTU2	Timer Interrupt Enable Register	TIER	8	8	2 or 3 PCLKB
0008 8805h	MTU2	Timer Status Register	TSR	8	8	2 or 3 PCLKB
0008 8806h	MTU2	Timer Counter	TCNT	16	16	2 or 3 PCLKB
0008 8808h	MTU2	Timer General Register A	TGRA	16	16	2 or 3 PCLKB
0008 880Ah	MTU2	Timer General Register B	TGRB	16	16	2 or 3 PCLKB
0008 8880h	MTU5	Timer Counter U	TCNTU	16	16	2 or 3 PCLKB
0008 8882h	MTU5	Timer General Register U	TGRU	16	16	2 or 3 PCLKB
0008 8884h	MTU5	Timer Control Register U	TCRU	8	8	2 or 3 PCLKB
0008 8886h	MTU5	Timer I/O Control Register U	TIORU	8	8	2 or 3 PCLKB
0008 8890h	MTU5	Timer Counter V	TCNTV	16	16	2 or 3 PCLKB
0008 8892h	MTU5	Timer General Register V	TGRV	16	16	2 or 3 PCLKB
0008 8894h	MTU5	Timer Control Register V	TCRV	8	8	2 or 3 PCLKB
0008 8896h	MTU5	Timer I/O Control Register V	TIORV	8	8	2 or 3 PCLKB
0008 88A0h	MTU5	Timer Counter W	TCNTW	16	16	2 or 3 PCLKB

Table 4.1 List of I/O Registers (Address Order) (9/16)

Address	Module Symbol	Register Name	Register Symbol	Number of Bits	Access Size	Number of Access States
0008 88A2h	MTU5	Timer General Register W	TGRW	16	16	2 or 3 PCLKB
0008 88A4h	MTU5	Timer Control Register W	TCRW	8	8	2 or 3 PCLKB
0008 88A6h	MTU5	Timer I/O Control Register W	TIORW	8	8	2 or 3 PCLKB
0008 88B2h	MTU5	Timer Interrupt Enable Register	TIER	8	8	2 or 3 PCLKB
0008 88B4h	MTU5	Timer Start Register	TSTR	8	8	2 or 3 PCLKB
0008 88B6h	MTU5	Timer Compare Match Clear Register	TCNTCMPCLR	8	8	2 or 3 PCLKB
0008 8900h	POE	Input Level Control/Status Register 1	ICSR1	16	8, 16	2 or 3 PCLKB
0008 8902h	POE	Output Level Control/Status Register 1	OCSR1	16	8, 16	2 or 3 PCLKB
0008 8908h	POE	Input Level Control/Status Register 2	ICSR2	16	8, 16	2 or 3 PCLKB
0008 890Ah	POE	Software Port Output Enable Register	SPOER	8	8	2 or 3 PCLKB
0008 890Bh	POE	Port Output Enable Control Register 1	POECR1	8	8	2 or 3 PCLKB
0008 890Ch	POE	Port Output Enable Control Register 2	POECR2	8	8	2 or 3 PCLKB
0008 890Eh	POE	Input Level Control/Status Register 3	ICSR3	16	8, 16	2 or 3 PCLKB
0008 9000h	S12AD	A/D Control Register	ADCSR	16	16	2 or 3 PCLKB
0008 9004h	S12AD	A/D Channel Select Register A	ADANSA	16	16	2 or 3 PCLKB
0008 9008h	S12AD	A/D-Converted Value Addition Mode Select Register	ADADS	16	16	2 or 3 PCLKB
0008 900Ch	S12AD	A/D-Converted Value Addition Count Select Register	ADADC	8	8	2 or 3 PCLKB
0008 900Eh	S12AD	A/D Control Extended Register	ADCER	16	16	2 or 3 PCLKB
0008 9010h	S12AD	A/D Start Trigger Select Register	ADSTRGR	16	16	2 or 3 PCLKB
0008 9012h	S12AD	A/D Converted Extended Input Control Register	ADEXICR	16	16	2 or 3 PCLKB
0008 9014h	S12AD	A/D Channel Select Register B	ADANSB	16	16	2 or 3 PCLKB
0008 9018h	S12AD	A/D Data Duplication Register	ADDBLDR	16	16	2 or 3 PCLKB
0008 901Ah	S12AD	A/D Temperature Sensor Data Register	ADTSRDR	16	16	2 or 3 PCLKB
0008 901Ch	S12AD	A/D Internal Reference Voltage Data Register	ADOCDR	16	16	2 or 3 PCLKB
0008 9020h	S12AD	A/D Data Register 0	ADDR0	16	16	2 or 3 PCLKB
0008 9022h	S12AD	A/D Data Register 1	ADDR1	16	16	2 or 3 PCLKB
0008 9024h	S12AD	A/D Data Register 2	ADDR2	16	16	2 or 3 PCLKB
0008 9026h	S12AD	A/D Data Register 3	ADDR3	16	16	2 or 3 PCLKB
0008 9028h	S12AD	A/D Data Register 4	ADDR4	16	16	2 or 3 PCLKB
0008 902Ch	S12AD	A/D Data Register 6	ADDR6	16	16	2 or 3 PCLKB
0008 9030h	S12AD	A/D Data Register 8	ADDR8	16	16	2 or 3 PCLKB
0008 9032h	S12AD	A/D Data Register 9	ADDR9	16	16	2 or 3 PCLKB
0008 9034h	S12AD	A/D Data Register 10	ADDR10	16	16	2 or 3 PCLKB
0008 9036h	S12AD	A/D Data Register 11	ADDR11	16	16	2 or 3 PCLKB
0008 9038h	S12AD	A/D Data Register 12	ADDR12	16	16	2 or 3 PCLKB
0008 903Ah	S12AD	A/D Data Register 13	ADDR13	16	16	2 or 3 PCLKB
0008 903Ch	S12AD	A/D Data Register 14	ADDR14	16	16	2 or 3 PCLKB
0008 903Eh	S12AD	A/D Data Register 15	ADDR15	16	16	2 or 3 PCLKB
0008 9060h	S12AD	A/D Sampling State Register 0	ADSSTR0	8	8	2 or 3 PCLKB
0008 9061h	S12AD	A/D Sampling State Register L	ADSSTRL	8	8	2 or 3 PCLKB
0008 9070h	S12AD	A/D Sampling State Register T	ADSSTRT	8	8	2 or 3 PCLKB
0008 9071h	S12AD	A/D Sampling State Register O	ADSSTRO	8	8	2 or 3 PCLKB
0008 9073h	S12AD	A/D Sampling State Register 1	ADSSTR1	8	8	2 or 3 PCLKB
0008 9074h	S12AD	A/D Sampling State Register 2	ADSSTR2	8	8	2 or 3 PCLKB
0008 9075h	S12AD	A/D Sampling State Register 3	ADSSTR3	8	8	2 or 3 PCLKB
0008 9076h	S12AD	A/D Sampling State Register 4	ADSSTR4	8	8	2 or 3 PCLKB
0008 9078h	S12AD	A/D Sampling State Register 6	ADSSTR6	8	8	2 or 3 PCLKB
0008 A020h	SCI1	Serial Mode Register	SMR	8	8	2 or 3 PCLKB
0008 A021h	SCI1	Bit Rate Register	BRR	8	8	2 or 3 PCLKB
0008 A022h	SCI1	Serial Control Register	SCR	8	8	2 or 3 PCLKB
0008 A023h	SCI1	Transmit Data Register	TDR	8	8	2 or 3 PCLKB
0008 A024h	SCI1	Serial Status Register	SSR	8	8	2 or 3 PCLKB

Table 4.1 List of I/O Registers (Address Order) (10/16)

Address	Module Symbol	Register Name	Register Symbol	Number of Bits	Access Size	Number of Access States
0008 A025h	SCI1	Receive Data Register	RDR	8	8	2 or 3 PCLKB
0008 A026h	SCI1	Smart Card Mode Register	SCMR	8	8	2 or 3 PCLKB
0008 A027h	SCI1	Serial Extended Mode Register	SEMR	8	8	2 or 3 PCLKB
0008 A028h	SCI1	Noise Filter Setting Register	SNFR	8	8	2 or 3 PCLKB
0008 A029h	SCI1	I ² C Mode Register 1	SIMR1	8	8	2 or 3 PCLKB
0008 A02Ah	SCI1	I ² C Mode Register 2	SIMR2	8	8	2 or 3 PCLKB
0008 A02Bh	SCI1	I ² C Mode Register 3	SIMR3	8	8	2 or 3 PCLKB
0008 A02Ch	SCI1	I ² C Status Register	SISR	8	8	2 or 3 PCLKB
0008 A02Dh	SCI1	SPI Mode Register	SPMR	8	8	2 or 3 PCLKB
0008 A0A0h	SCI5	Serial Mode Register	SMR	8	8	2 or 3 PCLKB
0008 A0A1h	SCI5	Bit Rate Register	BRR	8	8	2 or 3 PCLKB
0008 A0A2h	SCI5	Serial Control Register	SCR	8	8	2 or 3 PCLKB
0008 A0A3h	SCI5	Transmit Data Register	TDR	8	8	2 or 3 PCLKB
0008 A0A4h	SCI5	Serial Status Register	SSR	8	8	2 or 3 PCLKB
0008 A0A5h	SCI5	Receive Data Register	RDR	8	8	2 or 3 PCLKB
0008 A0A6h	SCI5	Smart Card Mode Register	SCMR	8	8	2 or 3 PCLKB
0008 A0A7h	SCI5	Serial Extended Mode Register	SEMR	8	8	2 or 3 PCLKB
0008 A0A8h	SCI5	Noise Filter Setting Register	SNFR	8	8	2 or 3 PCLKB
0008 A0A9h	SCI5	I ² C Mode Register 1	SIMR1	8	8	2 or 3 PCLKB
0008 A0AAh	SCI5	I ² C Mode Register 2	SIMR2	8	8	2 or 3 PCLKB
0008 A0ABh	SCI5	I ² C Mode Register 3	SIMR3	8	8	2 or 3 PCLKB
0008 A0ACh	SCI5	I ² C Status Register	SISR	8	8	2 or 3 PCLKB
0008 A0ADh	SCI5	SPI Mode Register	SPMR	8	8	2 or 3 PCLKB
0008 B000h	CAC	CAC Control Register 0	CACR0	8	8	2 or 3 PCLKB
0008 B001h	CAC	CAC Control Register 1	CACR1	8	8	2 or 3 PCLKB
0008 B002h	CAC	CAC Control Register 2	CACR2	8	8	2 or 3 PCLKB
0008 B003h	CAC	CAC Interrupt Request Enable Register	CAICR	8	8	2 or 3 PCLKB
0008 B004h	CAC	CAC Status Register	CASTR	8	8	2 or 3 PCLKB
0008 B006h	CAC	CAC Upper-Limit Value Setting Register	CAULVR	16	16	2 or 3 PCLKB
0008 B008h	CAC	CAC Lower-Limit Value Setting Register	CALLVR	16	16	2 or 3 PCLKB
0008 B00Ah	CAC	CAC Counter Buffer Register	CACNTBR	16	16	2 or 3 PCLKB
0008 B080h	DOC	DOC Control Register	DOCR	8	8	2 or 3 PCLKB
0008 B082h	DOC	DOC Data Input Register	DODIR	16	16	2 or 3 PCLKB
0008 B084h	DOC	DOC Data Setting Register	DODSR	16	16	2 or 3 PCLKB
0008 B100h	ELC	Event Link Control Register	ELCR	8	8	2 or 3 PCLKB
0008 B102h	ELC	Event Link Setting Register 1	ELSR1	8	8	2 or 3 PCLKB
0008 B103h	ELC	Event Link Setting Register 2	ELSR2	8	8	2 or 3 PCLKB
0008 B104h	ELC	Event Link Setting Register 3	ELSR3	8	8	2 or 3 PCLKB
0008 B105h	ELC	Event Link Setting Register 4	ELSR4	8	8	2 or 3 PCLKB
0008 B108h	ELC	Event Link Setting Register 7	ELSR7	8	8	2 or 3 PCLKB
0008 B110h	ELC	Event Link Setting Register 15	ELSR15	8	8	2 or 3 PCLKB
0008 B111h	ELC	Event Link Setting Register 16	ELSR16	8	8	2 or 3 PCLKB
0008 B113h	ELC	Event Link Setting Register 18	ELSR18	8	8	2 or 3 PCLKB
0008 B115h	ELC	Event Link Setting Register 20	ELSR20	8	8	2 or 3 PCLKB
0008 B117h	ELC	Event Link Setting Register 22	ELSR22	8	8	2 or 3 PCLKB
0008 B119h	ELC	Event Link Setting Register 24	ELSR24	8	8	2 or 3 PCLKB
0008 B11Ah	ELC	Event Link Setting Register 25	ELSR25	8	8	2 or 3 PCLKB
0008 B11Fh	ELC	Event Link Option Setting Register A	ELOPA	8	8	2 or 3 PCLKB
0008 B120h	ELC	Event Link Option Setting Register B	ELOPB	8	8	2 or 3 PCLKB
0008 B121h	ELC	Event Link Option Setting Register C	ELOPC	8	8	2 or 3 PCLKB
0008 B123h	ELC	Port Group Setting Register 1	PGR1	8	8	2 or 3 PCLKB
0008 B125h	ELC	Port Group Control Register 1	PGC1	8	8	2 or 3 PCLKB

Table 4.1 List of I/O Registers (Address Order) (11/16)

Address	Module Symbol	Register Name	Register Symbol	Number of Bits	Access Size	Number of Access States
0008 B127h	ELC	Port Buffer Register 1	PDBF1	8	8	2 or 3 PCLKB
0008 B129h	ELC	Event Link Port Setting Register 0	PEL0	8	8	2 or 3 PCLKB
0008 B12Ah	ELC	Event Link Port Setting Register 1	PEL1	8	8	2 or 3 PCLKB
0008 B12Dh	ELC	Event Link Software Event Generation Register	ELSEGR	8	8	2 or 3 PCLKB
0008 B300h	SCI12	Serial Mode Register	SMR	8	8	2 or 3 PCLKB
0008 B301h	SCI12	Bit Rate Register	BRR	8	8	2 or 3 PCLKB
0008 B302h	SCI12	Serial Control Register	SCR	8	8	2 or 3 PCLKB
0008 B303h	SCI12	Transmit Data Register	TDR	8	8	2 or 3 PCLKB
0008 B304h	SCI12	Serial Status Register	SSR	8	8	2 or 3 PCLKB
0008 B305h	SCI12	Receive Data Register	RDR	8	8	2 or 3 PCLKB
0008 B306h	SCI12	Smart Card Mode Register	SCMR	8	8	2 or 3 PCLKB
0008 B307h	SCI12	Serial Extended Mode Register	SEMR	8	8	2 or 3 PCLKB
0008 B308h	SCI12	Noise Filter Setting Register	SNFR	8	8	2 or 3 PCLKB
0008 B309h	SCI12	I ² C Mode Register 1	SIMR1	8	8	2 or 3 PCLKB
0008 B30Ah	SCI12	I ² C Mode Register 2	SIMR2	8	8	2 or 3 PCLKB
0008 B30Bh	SCI12	I ² C Mode Register 3	SIMR3	8	8	2 or 3 PCLKB
0008 B30Ch	SCI12	I ² C Status Register	SISR	8	8	2 or 3 PCLKB
0008 B30Dh	SCI12	SPI Mode Register	SPMR	8	8	2 or 3 PCLKB
0008 B320h	SCI12	Extended Serial Mode Enable Register	ESMER	8	8	2 or 3 PCLKB
0008 B321h	SCI12	Control Register 0	CR0	8	8	2 or 3 PCLKB
0008 B322h	SCI12	Control Register 1	CR1	8	8	2 or 3 PCLKB
0008 B323h	SCI12	Control Register 2	CR2	8	8	2 or 3 PCLKB
0008 B324h	SCI12	Control Register 3	CR3	8	8	2 or 3 PCLKB
0008 B325h	SCI12	Port Control Register	PCR	8	8	2 or 3 PCLKB
0008 B326h	SCI12	Interrupt Control Register	ICR	8	8	2 or 3 PCLKB
0008 B327h	SCI12	Status Register	STR	8	8	2 or 3 PCLKB
0008 B328h	SCI12	Status Clear Register	STCR	8	8	2 or 3 PCLKB
0008 B329h	SCI12	Control Field 0 Data Register	CF0DR	8	8	2 or 3 PCLKB
0008 B32Ah	SCI12	Control Field 0 Compare Enable Register	CF0CR	8	8	2 or 3 PCLKB
0008 B32Bh	SCI12	Control Field 0 Receive Data Register	CF0RR	8	8	2 or 3 PCLKB
0008 B32Ch	SCI12	Primary Control Field 1 Data Register	PCF1DR	8	8	2 or 3 PCLKB
0008 B32Dh	SCI12	Secondary Control Field 1 Data Register	SCF1DR	8	8	2 or 3 PCLKB
0008 B32Eh	SCI12	Control Field 1 Compare Enable Register	CF1CR	8	8	2 or 3 PCLKB
0008 B32Fh	SCI12	Control Field 1 Receive Data Register	CF1RR	8	8	2 or 3 PCLKB
0008 B330h	SCI12	Timer Control Register	TCR	8	8	2 or 3 PCLKB
0008 B331h	SCI12	Timer Mode Register	TMR	8	8	2 or 3 PCLKB
0008 B332h	SCI12	Timer Prescaler Register	TPRE	8	8	2 or 3 PCLKB
0008 B333h	SCI12	Timer Count Register	TCNT	8	8	2 or 3 PCLKB
0008 C000h	PORT0	Port Direction Register	PDR	8	8	2 or 3 PCLKB
0008 C001h	PORT1	Port Direction Register	PDR	8	8	2 or 3 PCLKB
0008 C002h	PORT2	Port Direction Register	PDR	8	8	2 or 3 PCLKB
0008 C003h	PORT3	Port Direction Register	PDR	8	8	2 or 3 PCLKB
0008 C004h	PORT4	Port Direction Register	PDR	8	8	2 or 3 PCLKB
0008 C005h	PORT5	Port Direction Register	PDR	8	8	2 or 3 PCLKB
0008 C00Ah	PORTA	Port Direction Register	PDR	8	8	2 or 3 PCLKB
0008 C00Bh	PORTB	Port Direction Register	PDR	8	8	2 or 3 PCLKB
0008 C00Ch	PORTC	Port Direction Register	PDR	8	8	2 or 3 PCLKB
0008 C00Eh	PORTE	Port Direction Register	PDR	8	8	2 or 3 PCLKB
0008 C012h	PORTJ	Port Direction Register	PDR	8	8	2 or 3 PCLKB
0008 C020h	PORT0	Port Output Data Register	PODR	8	8	2 or 3 PCLKB
0008 C021h	PORT1	Port Output Data Register	PODR	8	8	2 or 3 PCLKB
0008 C022h	PORT2	Port Output Data Register	PODR	8	8	2 or 3 PCLKB

Table 4.1 List of I/O Registers (Address Order) (12/16)

Address	Module Symbol	Register Name	Register Symbol	Number of Bits	Access Size	Number of Access States
0008 C023h	PORT3	Port Output Data Register	PODR	8	8	2 or 3 PCLKB
0008 C024h	PORT4	Port Output Data Register	PODR	8	8	2 or 3 PCLKB
0008 C025h	PORT5	Port Output Data Register	PODR	8	8	2 or 3 PCLKB
0008 C02Ah	PORTA	Port Output Data Register	PODR	8	8	2 or 3 PCLKB
0008 C02Bh	PORTB	Port Output Data Register	PODR	8	8	2 or 3 PCLKB
0008 C02Ch	PORTC	Port Output Data Register	PODR	8	8	2 or 3 PCLKB
0008 C02Eh	PORTE	Port Output Data Register	PODR	8	8	2 or 3 PCLKB
0008 C032h	PORTJ	Port Output Data Register	PODR	8	8	2 or 3 PCLKB
0008 C040h	PORT0	Port Input Data Register	PIDR	8	8	3 or 4 PCLKB cycles when reading, 2 or 3 PCLKB cycles when writing
0008 C041h	PORT1	Port Input Data Register	PIDR	8	8	3 or 4 PCLKB cycles when reading, 2 or 3 PCLKB cycles when writing
0008 C042h	PORT2	Port Input Data Register	PIDR	8	8	3 or 4 PCLKB cycles when reading, 2 or 3 PCLKB cycles when writing
0008 C043h	PORT3	Port Input Data Register	PIDR	8	8	3 or 4 PCLKB cycles when reading, 2 or 3 PCLKB cycles when writing
0008 C044h	PORT4	Port Input Data Register	PIDR	8	8	3 or 4 PCLKB cycles when reading, 2 or 3 PCLKB cycles when writing
0008 C045h	PORT5	Port Input Data Register	PIDR	8	8	3 or 4 PCLKB cycles when reading, 2 or 3 PCLKB cycles when writing
0008 C04Ah	PORTA	Port Input Data Register	PIDR	8	8	3 or 4 PCLKB cycles when reading, 2 or 3 PCLKB cycles when writing
0008 C04Bh	PORTB	Port Input Data Register	PIDR	8	8	3 or 4 PCLKB cycles when reading, 2 or 3 PCLKB cycles when writing
0008 C04Ch	PORTC	Port Input Data Register	PIDR	8	8	3 or 4 PCLKB cycles when reading, 2 or 3 PCLKB cycles when writing
0008 C04Eh	PORTE	Port Input Data Register	PIDR	8	8	3 or 4 PCLKB cycles when reading, 2 or 3 PCLKB cycles when writing
0008 C051h	PORTH	Port Input Data Register	PIDR	8	8	3 or 4 PCLKB cycles when reading, 2 or 3 PCLKB cycles when writing
0008 C052h	PORTJ	Port Input Data Register	PIDR	8	8	3 or 4 PCLKB cycles when reading, 2 or 3 PCLKB cycles when writing
0008 C060h	PORT0	Port Mode Register	PMR	8	8	2 or 3 PCLKB
0008 C061h	PORT1	Port Mode Register	PMR	8	8	2 or 3 PCLKB
0008 C062h	PORT2	Port Mode Register	PMR	8	8	2 or 3 PCLKB
0008 C063h	PORT3	Port Mode Register	PMR	8	8	2 or 3 PCLKB
0008 C064h	PORT4	Port Mode Register	PMR	8	8	2 or 3 PCLKB
0008 C065h	PORT5	Port Mode Register	PMR	8	8	2 or 3 PCLKB
0008 C06Ah	PORTA	Port Mode Register	PMR	8	8	2 or 3 PCLKB
0008 C06Bh	PORTB	Port Mode Register	PMR	8	8	2 or 3 PCLKB
0008 C06Ch	PORTC	Port Mode Register	PMR	8	8	2 or 3 PCLKB
0008 C06Eh	PORTE	Port Mode Register	PMR	8	8	2 or 3 PCLKB
0008 C071h	PORTH	Port Mode Register	PMR	8	8	2 or 3 PCLKB
0008 C072h	PORTJ	Port Mode Register	PMR	8	8	2 or 3 PCLKB

Table 4.1 List of I/O Registers (Address Order) (13/16)

Address	Module Symbol	Register Name	Register Symbol	Number of Bits	Access Size	Number of Access States
0008 C083h	PORT1	Open Drain Control Register 1	ODR1	8	8, 16	2 or 3 PCLKB
0008 C085h	PORT2	Open Drain Control Register 1	ODR1	8	8, 16	2 or 3 PCLKB
0008 C086h	PORT3	Open Drain Control Register 0	ODR0	8	8, 16	2 or 3 PCLKB
0008 C094h	PORTA	Open Drain Control Register 0	ODR0	8	8, 16	2 or 3 PCLKB
0008 C095h	PORTA	Open Drain Control Register 1	ODR1	8	8, 16	2 or 3 PCLKB
0008 C096h	PORTB	Open Drain Control Register 0	ODR0	8	8, 16	2 or 3 PCLKB
0008 C097h	PORTB	Open Drain Control Register 1	ODR1	8	8, 16	2 or 3 PCLKB
0008 C098h	PORTC	Open Drain Control Register 0	ODR0	8	8, 16	2 or 3 PCLKB
0008 C099h	PORTC	Open Drain Control Register 1	ODR1	8	8, 16	2 or 3 PCLKB
0008 C09Ch	PORTE	Open Drain Control Register 0	ODR0	8	8, 16	2 or 3 PCLKB
0008 C09Dh	PORTE	Open Drain Control Register 1	ODR1	8	8, 16	2 or 3 PCLKB
0008 C0C0h	PORT0	Pull-Up Control Register	PCR	8	8	2 or 3 PCLKB
0008 C0C1h	PORT1	Pull-Up Control Register	PCR	8	8	2 or 3 PCLKB
0008 C0C2h	PORT2	Pull-Up Control Register	PCR	8	8	2 or 3 PCLKB
0008 C0C3h	PORT3	Pull-Up Control Register	PCR	8	8	2 or 3 PCLKB
0008 C0C5h	PORT5	Pull-Up Control Register	PCR	8	8	2 or 3 PCLKB
0008 C0CAh	PORTA	Pull-Up Control Register	PCR	8	8	2 or 3 PCLKB
0008 C0CBh	PORTB	Pull-Up Control Register	PCR	8	8	2 or 3 PCLKB
0008 C0CCh	PORTC	Pull-Up Control Register	PCR	8	8	2 or 3 PCLKB
0008 C0CEh	PORTE	Pull-Up Control Register	PCR	8	8	2 or 3 PCLKB
0008 C11Fh	MPC	Write-Protect Register	PWPR	8	8	2 or 3 PCLKB
0008 C120h	PORT	Port Switching Register B	PSRB	8	8	2 or 3 PCLKB
0008 C121h	PORT	Port Switching Register A	PSRA	8	8	2 or 3 PCLKB
0008 C143h	MPC	P03 Pin Function Control Register	P03PFS	8	8	2 or 3 PCLKB
0008 C145h	MPC	P05 Pin Function Control Register	P05PFS	8	8	2 or 3 PCLKB
0008 C14Ch	MPC	P14 Pin Function Control Register	P14PFS	8	8	2 or 3 PCLKB
0008 C14Dh	MPC	P15 Pin Function Control Register	P15PFS	8	8	2 or 3 PCLKB
0008 C14Eh	MPC	P16 Pin Function Control Register	P16PFS	8	8	2 or 3 PCLKB
0008 C14Fh	MPC	P17 Pin Function Control Register	P17PFS	8	8	2 or 3 PCLKB
0008 C156h	MPC	P26 Pin Function Control Register	P26PFS	8	8	2 or 3 PCLKB
0008 C157h	MPC	P27 Pin Function Control Register	P27PFS	8	8	2 or 3 PCLKB
0008 C158h	MPC	P30 Pin Function Control Register	P30PFS	8	8	2 or 3 PCLKB
0008 C159h	MPC	P31 Pin Function Control Register	P31PFS	8	8	2 or 3 PCLKB
0008 C15Ah	MPC	P32 Pin Function Control Register	P32PFS	8	8	2 or 3 PCLKB
0008 C160h	MPC	P40 Pin Function Control Register	P40PFS	8	8	2 or 3 PCLKB
0008 C161h	MPC	P41 Pin Function Control Register	P41PFS	8	8	2 or 3 PCLKB
0008 C162h	MPC	P42 Pin Function Control Register	P42PFS	8	8	2 or 3 PCLKB
0008 C163h	MPC	P43 Pin Function Control Register	P43PFS	8	8	2 or 3 PCLKB
0008 C164h	MPC	P44 Pin Function Control Register	P44PFS	8	8	2 or 3 PCLKB
0008 C166h	MPC	P46 Pin Function Control Register	P46PFS	8	8	2 or 3 PCLKB
0008 C16Ch	MPC	P54 Pin Function Control Register	P54PFS	8	8	2 or 3 PCLKB
0008 C16Dh	MPC	P55 Pin Function Control Register	P55PFS	8	8	2 or 3 PCLKB
0008 C190h	MPC	PA0 Pin Function Control Register	PA0PFS	8	8	2 or 3 PCLKB
0008 C191h	MPC	PA1 Pin Function Control Register	PA1PFS	8	8	2 or 3 PCLKB
0008 C193h	MPC	PA3 Pin Function Control Register	PA3PFS	8	8	2 or 3 PCLKB
0008 C194h	MPC	PA4 Pin Function Control Register	PA4PFS	8	8	2 or 3 PCLKB
0008 C196h	MPC	PA6 Pin Function Control Register	PA6PFS	8	8	2 or 3 PCLKB
0008 C198h	MPC	PB0 Pin Function Control Register	PB0PFS	8	8	2 or 3 PCLKB
0008 C199h	MPC	PB1 Pin Function Control Register	PB1PFS	8	8	2 or 3 PCLKB
0008 C19Bh	MPC	PB3 Pin Function Control Register	PB3PFS	8	8	2 or 3 PCLKB
0008 C19Dh	MPC	PB5 Pin Function Control Register	PB5PFS	8	8	2 or 3 PCLKB
0008 C19Eh	MPC	PB6 Pin Function Control Register	PB6PFS	8	8	2 or 3 PCLKB

Table 4.1 List of I/O Registers (Address Order) (14/16)

Address	Module Symbol	Register Name	Register Symbol	Number of Bits	Access Size	Number of Access States
0008 C19Fh	MPC	PB7 Pin Function Control Register	PB7PFS	8	8	2 or 3 PCLKB
0008 C1A2h	MPC	PC2 Pin Function Control Register	PC2PFS	8	8	2 or 3 PCLKB
0008 C1A3h	MPC	PC3 Pin Function Control Register	PC3PFS	8	8	2 or 3 PCLKB
0008 C1A4h	MPC	PC4 Pin Function Control Register	PC4PFS	8	8	2 or 3 PCLKB
0008 C1A5h	MPC	PC5 Pin Function Control Register	PC5PFS	8	8	2 or 3 PCLKB
0008 C1A6h	MPC	PC6 Pin Function Control Register	PC6PFS	8	8	2 or 3 PCLKB
0008 C1A7h	MPC	PC7 Pin Function Control Register	PC7PFS	8	8	2 or 3 PCLKB
0008 C1B0h	MPC	PE0 Pin Function Control Register	PE0PFS	8	8	2 or 3 PCLKB
0008 C1B1h	MPC	PE1 Pin Function Control Register	PE1PFS	8	8	2 or 3 PCLKB
0008 C1B2h	MPC	PE2 Pin Function Control Register	PE2PFS	8	8	2 or 3 PCLKB
0008 C1B3h	MPC	PE3 Pin Function Control Register	PE3PFS	8	8	2 or 3 PCLKB
0008 C1B4h	MPC	PE4 Pin Function Control Register	PE4PFS	8	8	2 or 3 PCLKB
0008 C1B5h	MPC	PE5 Pin Function Control Register	PE5PFS	8	8	2 or 3 PCLKB
0008 C1B6h	MPC	PE6 Pin Function Control Register	PE6PFS	8	8	2 or 3 PCLKB
0008 C1B7h	MPC	PE7 Pin Function Control Register	PE7PFS	8	8	2 or 3 PCLKB
0008 C1D6h	MPC	PJ6 Pin Function Control Register	PJ6PFS	8	8	2 or 3 PCLKB
0008 C1D7h	MPC	PJ7 Pin Function Control Register	PJ7PFS	8	8	2 or 3 PCLKB
0008 C290h	SYSTEM	Reset Status Register 0	RSTSR0	8	8	4 or 5 PCLKB
0008 C291h	SYSTEM	Reset Status Register 1	RSTSR1	8	8	4 or 5 PCLKB
0008 C293h	SYSTEM	Main Clock Oscillator Forced Oscillation Control Register	MOFCR	8	8	4 or 5 PCLKB
0008 C297h	SYSTEM	Voltage Monitoring Circuit Control Register	LVCMPCR	8	8	4 or 5 PCLKB
0008 C298h	SYSTEM	Voltage Detection Level Select Register	LVDLVLR	8	8	4 or 5 PCLKB
0008 C29Ah	SYSTEM	Voltage Monitoring 1 Circuit Control Register 0	LVD1CR0	8	8	4 or 5 PCLKB
0008 C29Bh	SYSTEM	Voltage Monitoring 2 Circuit Control Register 0	LVD2CR0	8	8	4 or 5 PCLKB
0008 C400h	RTC	64-Hz Counter	R64CNT	8	8	2 or 3 PCLKB
0008 C402h	RTC	Second Counter	RSECCNT	8	8	2 or 3 PCLKB
0008 C402h	RTC	Binary Counter 0	BCNT0	8	8	2 or 3 PCLKB
0008 C404h	RTC	Minute Counter	RMINCNT	8	8	2 or 3 PCLKB
0008 C404h	RTC	Binary Counter 1	BCNT1	8	8	2 or 3 PCLKB
0008 C406h	RTC	Hour Counter	RHRCNT	8	8	2 or 3 PCLKB
0008 C406h	RTC	Binary Counter 2	BCNT2	8	8	2 or 3 PCLKB
0008 C408h	RTC	Day-Of-Week Counter	RWKCNT	8	8	2 or 3 PCLKB
0008 C408h	RTC	Binary Counter 3	BCNT3	8	8	2 or 3 PCLKB
0008 C40Ah	RTC	Date Counter	RDAYCNT	8	8	2 or 3 PCLKB
0008 C40Ch	RTC	Month Counter	RMONCNT	8	8	2 or 3 PCLKB
0008 C40Eh	RTC	Year Counter	RYRCNT	16	16	2 or 3 PCLKB
0008 C410h	RTC	Second Alarm Register	RSECAR	8	8	2 or 3 PCLKB
0008 C410h	RTC	Binary Counter 0 Alarm Register	BCNT0AR	8	8	2 or 3 PCLKB
0008 C412h	RTC	Minute Alarm Register	RMINAR	8	8	2 or 3 PCLKB
0008 C412h	RTC	Binary Counter 1 Alarm Register	BCNT1AR	8	8	2 or 3 PCLKB
0008 C414h	RTC	Hour Alarm Register	RHRAR	8	8	2 or 3 PCLKB
0008 C414h	RTC	Binary Counter 2 Alarm Register	BCNT2AR	8	8	2 or 3 PCLKB
0008 C416h	RTC	Day-of-Week Alarm Register	RWKAR	8	8	2 or 3 PCLKB
0008 C416h	RTC	Binary Counter 3 Alarm Register	BCNT3AR	8	8	2 or 3 PCLKB
0008 C418h	RTC	Date Alarm Register	RDAYAR	8	8	2 or 3 PCLKB
0008 C418h	RTC	Binary Counter 0 Alarm Enable Register	BCNT0AER	8	8	2 or 3 PCLKB
0008 C41Ah	RTC	Month Alarm Register	RMONAR	8	8	2 or 3 PCLKB
0008 C41Ah	RTC	Binary Counter 1 Alarm Enable Register	BCNT1AER	8	8	2 or 3 PCLKB
0008 C41Ch	RTC	Year Alarm Register	RYRAR	16	16	2 or 3 PCLKB
0008 C41Ch	RTC	Binary Counter 2 Alarm Enable Register	BCNT2AER	16	16	2 or 3 PCLKB
0008 C41Eh	RTC	Year Alarm Enable Register	RYRAREN	8	8	2 or 3 PCLKB
0008 C41Eh	RTC	Binary Counter 3 Alarm Enable Register	BCNT3AER	8	8	2 or 3 PCLKB

Table 4.1 List of I/O Registers (Address Order) (15/16)

Address	Module Symbol	Register Name	Register Symbol	Number of Bits	Access Size	Number of Access States
0008 C422h	RTC	RTC Control Register 1	RCR1	8	8	2 or 3 PCLKB
0008 C424h	RTC	RTC Control Register 2	RCR2	8	8	2 or 3 PCLKB
0008 C426h	RTC	RTC Control Register 3	RCR3	8	8	2 or 3 PCLKB
0008 C42Eh	RTC	Time Error Adjustment Register	RADJ	8	8	2 or 3 PCLKB
000A 0000h	USB0	System Configuration Control Register	SYSCFG	16	16	3 or 4 PCLKB
000A 0004h	USB0	System Configuration Status Register 0	SYSSTS0	16	16	9 PCLK or more
000A 0008h	USB0	Device State Control Register 0	DVSTCTR0	16	16	9 PCLK or more
000A 0014h	USB0	CFIFO Port Register	CFIFO	16	16	3 or 4 PCLKB
000A 0018h	USB0	D0FIFO Port Register	D0FIFO	16	16	3 or 4 PCLKB
000A 001Ch	USB0	D1FIFO Port Register	D1FIFO	16	16	3 or 4 PCLKB
000A 0020h	USB0	CFIFO Port Select Register	CFIFOSEL	16	16	3 or 4 PCLKB
000A 0028h	USB0	D0FIFO Port Select Register	D0FIFOSEL	16	16	3 or 4 PCLKB
000A 002Ch	USB0	D1FIFO Port Select Register	D1FIFOSEL	16	16	3 or 4 PCLKB
000A 0022h	USB0	CFIFO Port Control Register	CFIFOCTR	16	16	3 or 4 PCLKB
000A 002Ah	USB0	D0FIFO Port Control Register	D0FIFOCTR	16	16	3 or 4 PCLKB
000A 002Eh	USB0	D1FIFO Port Control Register	D1FIFOCTR	16	16	3 or 4 PCLKB
000A 0030h	USB0	Interrupt Enable Register 0	INTENB0	16	16	9 PCLKB or more
000A 0032h	USB0	Interrupt Enable Register 1	INTENB1	16	16	9 PCLKB or more
000A 0036h	USB0	BRDY Interrupt Enable Register	BRDYENB	16	16	9 PCLKB or more
000A 0038h	USB0	NRDY Interrupt Enable Register	NRDYENB	16	16	9 PCLKB or more
000A 003Ah	USB0	BEMP Interrupt Enable Register	BEMPENB	16	16	9 PCLKB or more
000A 003Ch	USB0	SOF Output Configuration Register	SOFCFG	16	16	9 PCLKB or more
000A 0040h	USB0	Interrupt Status Register 0	INTSTS0	16	16	9 PCLKB or more
000A 0042h	USB0	Interrupt Status Register 1	INTSTS1	16	16	9 PCLKB or more
000A 0046h	USB0	BRDY Interrupt Status Register	BRDYSTS	16	16	9 PCLKB or more
000A 0048h	USB0	NRDY Interrupt Status Register	NRDYSTS	16	16	9 PCLKB or more
000A 004Ah	USB0	BEMP Interrupt Status Register	BEMPSTS	16	16	9 PCLKB or more
000A 004Ch	USB0	Frame Number Register	FRMNUM	16	16	9 PCLKB or more
000A 0054h	USB0	USB Request Type Register	USBREQ	16	16	9 PCLKB or more
000A 0056h	USB0	USB Request Value Register	USBVAL	16	16	9 PCLKB or more
000A 0058h	USB0	USB Request Index Register	USBINDX	16	16	9 PCLKB or more
000A 005Ah	USB0	USB Request Length Register	USBLENG	16	16	9 PCLKB or more
000A 005Ch	USB0	DCP Configuration Register	DCPCFG	16	16	9 PCLKB or more
000A 005Eh	USB0	DCP Maximum Packet Size Register	DCPMAXP	16	16	9 PCLKB or more
000A 0060h	USB0	DCP Control Register	DCPCTR	16	16	9 PCLKB or more
000A 0064h	USB0	Pipe Window Select Register	PIPESEL	16	16	9 PCLKB or more
000A 0068h	USB0	Pipe Configuration Register	PIPECFG	16	16	9 PCLKB or more
000A 006Ch	USB0	Pipe Maximum Packet Size Register	PIPEMAXP	16	16	9 PCLKB or more
000A 006Eh	USB0	Pipe Cycle Control Register	PIPEPERI	16	16	9 PCLKB or more
000A 0070h	USB0	PIPE1 Control Register	PIPE1CTR	16	16	9 PCLKB or more
000A 0072h	USB0	PIPE2 Control Register	PIPE2CTR	16	16	9 PCLKB or more
000A 0074h	USB0	PIPE3 Control Register	PIPE3CTR	16	16	9 PCLKB or more
000A 0076h	USB0	PIPE4 Control Register	PIPE4CTR	16	16	9 PCLKB or more
000A 0078h	USB0	PIPE5 Control Register	PIPE5CTR	16	16	9 PCLKB or more
000A 007Ah	USB0	PIPE6 Control Register	PIPE6CTR	16	16	9 PCLKB or more
000A 007Ch	USB0	PIPE7 Control Register	PIPE7CTR	16	16	9 PCLKB or more
000A 007Eh	USB0	PIPE8 Control Register	PIPE8CTR	16	16	9 PCLKB or more
000A 0080h	USB0	PIPE9 Control Register	PIPE9CTR	16	16	9 PCLKB or more
000A 0090h	USB0	PIPE1 Transaction Counter Enable Register	PIPE1TRE	16	16	9 PCLKB or more
000A 0092h	USB0	PIPE1 Transaction Counter Register	PIPE1TRN	16	16	9 PCLKB or more
000A 0094h	USB0	PIPE2 Transaction Counter Enable Register	PIPE2TRE	16	16	9 PCLKB or more
000A 0096h	USB0	PIPE2 Transaction Counter Register	PIPE2TRN	16	16	9 PCLKB or more

Table 4.1 List of I/O Registers (Address Order) (16/16)

Address	Module Symbol	Register Name	Register Symbol	Number of Bits	Access Size	Number of Access States
000A 0098h	USB0	PIPE3 Transaction Counter Enable Register	PIPE3TRE	16	16	9 PCLKB or more
000A 009Ah	USB0	PIPE3 Transaction Counter Register	PIPE3TRN	16	16	9 PCLKB or more
000A 009Ch	USB0	PIPE4 Transaction Counter Enable Register	PIPE4TRE	16	16	9 PCLKB or more
000A 009Eh	USB0	PIPE4 Transaction Counter Register	PIPE4TRN	16	16	9 PCLKB or more
000A 00A0h	USB0	PIPE5 Transaction Counter Enable Register	PIPE5TRE	16	16	9 PCLKB or more
000A 00A2h	USB0	PIPE5 Transaction Counter Register	PIPE5TRN	16	16	9 PCLKB or more
000A 00B0h	USB0	BC Control Register 0	USBBCCTRL0	16	16	9 PCLKB or more
000A 00CCh	USB0	USB Module Control Register	USBMC	16	16	9 PCLKB or more
000A 00D0h	USB0	Device Address 0 Configuration Register	DEVADD0	16	16	9 PCLKB or more
000A 00D2h	USB0	Device Address 1 Configuration Register	DEVADD1	16	16	9 PCLKB or more
000A 00D4h	USB0	Device Address 2 Configuration Register	DEVADD2	16	16	9 PCLKB or more
000A 00D6h	USB0	Device Address 3 Configuration Register	DEVADD3	16	16	9 PCLKB or more
000A 00D8h	USB0	Device Address 4 Configuration Register	DEVADD4	16	16	9 PCLKB or more
000A 00DAh	USB0	Device Address 5 Configuration Register	DEVADD5	16	16	9 PCLKB or more
007F C090h	FLASH	E2 DataFlash Control Register	DFCTL	8	8	2 or 3 FCLK
007F C0ACh	TEMPS	Temperature Sensor Calibration Data Register	TSCDRL	8	8	1 or 2 PCLKB
007F C0ADh	TEMPS	Temperature Sensor Calibration Data Register	TSCDRH	8	8	1 or 2 PCLKB
007F C0B0h	FLASH	Flash Start-Up Setting Monitor Register	FSCMR	16	16	2 or 3 FCLK
007F C0B2h	FLASH	Flash Access Window Start Address Monitor	FAWSMR	16	16	2 or 3 FCLK
007F C0B4h	FLASH	Flash Access Window End Address Monitor Register	FAWEMR	16	16	2 or 3 FCLK
007F C0B6h	FLASH	Flash Initial Setting Register	FISR	8	8	2 or 3 FCLK
007F C0B7h	FLASH	Flash Extra Area Control Register	FEXCR	8	8	2 or 3 FCLK
007F C0B8h	FLASH	Flash Error Address Monitor Register L	FEAML	16	16	2 or 3 FCLK
007F C0BAh	FLASH	Flash Error Address Monitor Register H	FEAMH	8	8	2 or 3 FCLK
007F C0C0h	FLASH	Protection Unlock Register	FPR	8	8	2 or 3 FCLK
007F C0C1h	FLASH	Protection Unlock Status Register	FPSR	8	8	2 or 3 FCLK
007F C0C2h	FLASH	Flash Read Buffer Register L	FRBL	16	16	2 or 3 FCLK
007F C0C4h	FLASH	Flash Read Buffer Register H	FRBH	16	16	2 or 3 FCLK
007F FF80h	FLASH	Flash P/E Mode Control Register	FPMCR	8	8	2 or 3 FCLK
007F FF81h	FLASH	Flash Area Select Register	FASR	8	8	2 or 3 FCLK
007F FF82h	FLASH	Flash Processing Start Address Register L	FSARL	16	16	2 or 3 FCLK
007F FF84h	FLASH	Flash Processing Start Address Register H	FSARH	8	8	2 or 3 FCLK
007F FF85h	FLASH	Flash Control Register	FCR	8	8	2 or 3 FCLK
007F FF86h	FLASH	Flash Processing End Address Register L	FEARL	16	16	2 or 3 FCLK
007F FF88h	FLASH	Flash Processing End Address Register H	FEARH	8	8	2 or 3 FCLK
007F FF89h	FLASH	Flash Reset Register	FRESETR	8	8	2 or 3 FCLK
007F FF8Ah	FLASH	Flash Status Register 0	FSTATR0	8	8	2 or 3 FCLK
007F FF8Bh	FLASH	Flash Status Register 1	FSTATR1	8	8	2 or 3 FCLK
007F FF8Ch	FLASH	Flash Write Buffer Register L	FWBL	16	16	2 or 3 FCLK
007F FF8Eh	FLASH	Flash Write Buffer Register H	FWBH	16	16	2 or 3 FCLK
007F FFB2h	FLASH	Flash P/E Mode Entry Register	FENTRYR	16	16	2 or 3 FCLK

Note 1. Odd addresses cannot be accessed in 16-bit units. When accessing a register in 16-bit units, access the address of the TMOCNL register. Table 27.6 lists register allocation for 16-bit access in the User's Manual: Hardware.

5. Electrical Characteristics

5.1 Absolute Maximum Ratings

Table 5.1 Absolute Maximum Ratings

Conditions: VSS = AVSS0 = VREFL0 = VSS_USB = 0 V

Item		Symbol	Value	Unit
Power supply voltage		VCC, VCC_USB	-0.3 to +4.6	V
Input voltage	Ports for 5 V tolerant*1	V _{in}	-0.3 to +6.5	V
	Ports P40 to P44, P46, ports PJ6, PJ7	V _{in}	-0.3 to AVCC0 +0.3	V
	Ports other than above	V _{in}	-0.3 to VCC +0.3	V
Reference power supply voltage		VREFH0	-0.3 to AVCC0 +0.3	V
Analog power supply voltage		AVCC0	-0.3 to +4.6	V
Analog input voltage		V _{AN}	-0.3 to AVCC0 + 0.3 (when AN000 to AN004 and AN006 used) -0.3 to VCC + 0.3 (when AN008 to AN015 used)	V
Operating temperature*2		T _{opr}	-40 to +85 -40 to +105	°C
Storage temperature		T _{stg}	-55 to +125	°C

Caution: Permanent damage to the MCU may result if absolute maximum ratings are exceeded.

To preclude any malfunctions due to noise interference, insert capacitors of high frequency characteristics between the VCC and VSS pins, between the AVCC0 and AVSS0 pins, between the VCC_USB and VSS_USB pins, and between the VREFH0 and VREFL0 pins. Place capacitors of about 0.1 μF as close as possible to every power supply pin and use the shortest and heaviest possible traces. Also, connect capacitors as stabilization capacitance.

Connect the VCL pin to a VSS pin via a 4.7 μF capacitor. The capacitor must be placed close to the pin, refer to section 5.12.1, Connecting VCL Capacitor and Bypass Capacitors.

Do not input signals or an I/O pull-up power supply to ports other than 5-V tolerant ports while the device is not powered. The current injection that results from input of such a signal or I/O pull-up may cause malfunction and the abnormal current that passes in the device at this time may cause degradation of internal elements.

If input voltage (within the specified range from -0.3 to + 6.5V) is applied to 5-V tolerant ports, it will not cause problems such as damage to the MCU.

Note 1. Ports P16, P17, PA6, and PB0 are 5 V tolerant.

Note 2. The upper limit of operating temperature is 85°C or 105°C, depending on the product. For details, refer to 1.2 List of Products.

Table 5.2 Operating Conditions

Item	Symbol	Conditions	Min.	Typ.	Max.	Unit
Power supply voltages	VCC*1	When USB not used	1.8	—	3.6	V
		When USB used	3.0	—	3.6	V
	VSS		—	0	—	V
USB power supply voltages	VCC_USB		—	VCC	—	V
	VSS_USB		—	0	—	V
Analog power supply voltages	AVCC0*1, *2		1.8	—	3.6	V
	AVSS0		—	0	—	V
	VREFH0		1.8	—	AVCC0	V
	VREFL0		—	0	—	V

Note 1. When powering on AVCC0 and VCC, power them on at the same time or VCC first.

Note 2. For details, refer to section 30.7.10, Voltage Range of Analog Power Supply Pins in the User's Manual: Hardware.

5.2 DC Characteristics

Table 5.3 DC Characteristics (1)Conditions: $2.7\text{ V} \leq \text{VCC} = \text{VCC_USB} \leq 3.6\text{ V}$, $2.7\text{ V} \leq \text{AVSS0} \leq 3.6\text{ V}$, $\text{VSS} = \text{AVSS0} = \text{VSS_USB} = 0\text{ V}$, $T_a = -40\text{ to }+105^\circ\text{C}$

Item		Symbol	Min.	Typ.	Max.	Unit	Test Conditions
Schmitt trigger input voltage	RIIC input pin (except for SMBus, 5 V tolerant)	V_{IH}	$\text{VCC} \times 0.7$	—	5.8	V	
	Ports P16, P17, port PA6, port PB0 (5 V tolerant)		$\text{VCC} \times 0.8$	—	5.8		
	Ports P03, P05, ports P14, P15, ports P26, P27, ports P30 to P32, P35, ports P54, P55, ports PA0, PA1, PA3, PA4, ports PB1, PB3, PB5 to PB7, ports PC2 to PC7, ports PE0 to PE7, port PH7, RES#		$\text{VCC} \times 0.8$	—	$\text{VCC} + 0.3$		
	RIIC input pin (except for SMBus)	V_{IL}	-0.3	—	$\text{VCC} \times 0.3$		
	Other than RIIC input pin		-0.3	—	$\text{VCC} \times 0.2$		
	RIIC input pin (except for SMBus)	ΔV_T	$\text{VCC} \times 0.05$	—	—		
	Other than RIIC input pin		$\text{VCC} \times 0.1$	—	—		
Input voltage (except for Schmitt trigger input pins)	MD	V_{IH}	$\text{VCC} \times 0.9$	—	$\text{VCC} + 0.3$	V	
	XTAL (external clock input)		$\text{VCC} \times 0.8$	—	$\text{VCC} + 0.3$		
	Ports P40 to P44, P46, ports PJ6, PJ7		$\text{AVCC0} \times 0.7$	—	$\text{AVCC0} + 0.3$		
	RIIC input pin (SMBus)		2.1	—	$\text{VCC} + 0.3$		
	MD	V_{IL}	-0.3	—	$\text{VCC} \times 0.1$		
	XTAL (external clock input)		-0.3	—	$\text{VCC} \times 0.2$		
	Ports P40 to P44, P46, ports PJ6, PJ7		-0.3	—	$\text{AVCC0} \times 0.3$		
	RIIC input pin (SMBus)		-0.3	—	0.8		

Table 5.4 DC Characteristics (2)Conditions: $1.8\text{ V} \leq V_{CC} = V_{CC_USB} < 2.7\text{ V}$, $1.8\text{ V} \leq AV_{SS0} < 2.7\text{ V}$, $V_{SS} = AV_{SS0} = V_{SS_USB} = 0\text{ V}$, $T_a = -40\text{ to }+105^\circ\text{C}$

Item		Symbol	Min.	Typ.	Max.	Unit	Test Conditions
Schmitt trigger input voltage	Ports P16, P17, port PA6, port PB0 (5 V tolerant)	V_{IH}	$V_{CC} \times 0.8$	—	5.8	V	
	Ports P03, P05, ports P14, P15, ports P26, P27, ports P30 to P32, P35, ports P54, P55, ports PA0, PA1, PA3, PA4, ports PB1, PB3, PB5 to PB7, ports PC2 to PC7, ports PE0 to PE7, port PH7, RES#		$V_{CC} \times 0.8$	—	$V_{CC} + 0.3$		
	All pins		-0.3	—	$V_{CC} \times 0.2$		
	All pins	ΔV_T	$V_{CC} \times 0.01$	—	—		
Input voltage (except for Schmitt trigger input pins)	MD	V_{IH}	$V_{CC} \times 0.9$	—	$V_{CC} + 0.3$	V	
	XTAL (external clock input)		$V_{CC} \times 0.8$	—	$V_{CC} + 0.3$		
	Ports P40 to P44, P46, ports PJ6, PJ7		$AV_{CC0} \times 0.7$	—	$AV_{CC0} + 0.3$		
	MD	V_{IL}	-0.3	—	$V_{CC} \times 0.1$		
	XTAL (external clock input)		-0.3	—	$V_{CC} \times 0.2$		
	Ports P40 to P44, P46, ports PJ6, PJ7		-0.3	—	$AV_{CC0} \times 0.3$		

Table 5.5 DC Characteristics (3)Conditions: $1.8\text{ V} \leq V_{CC} = V_{CC_USB} \leq 3.6\text{ V}$, $1.8\text{ V} \leq AV_{SS0} \leq 3.6\text{ V}$, $V_{SS} = AV_{SS0} = V_{SS_USB} = 0\text{ V}$, $T_a = -40\text{ to }+105^\circ\text{C}$

Item		Symbol	Min.	Typ.	Max.	Unit	Test Conditions
Input leakage current	RES#, MD, port P35, port PH7	$ I_{in} $	—	—	1.0	μA	$V_{in} = 0\text{ V}$, V_{CC}
Three-state leakage current (off-state)	Ports for 5 V tolerant	$ I_{TSI} $	—	—	1.0	μA	$V_{in} = 0\text{ V}$, 5.8 V
	Pins other than above		—	—	1.0		$V_{in} = 0\text{ V}$, V_{CC}
Input capacitance	All input pins (except for port P16, port P35, USB0_DM, USB0_DP)	C_{in}	—	—	15	pF	$V_{in} = 0\text{ mV}$, Frequency: 1 MHz, $T_a = 25^\circ\text{C}$
	Port P16, port P35, USB0_DM, USB0_DP		—	—	30		

Table 5.6 DC Characteristics (4)Conditions: $1.8\text{ V} \leq V_{CC} = V_{CC_USB} \leq 3.6\text{ V}$, $1.8\text{ V} \leq AV_{SS0} \leq 3.6\text{ V}$, $V_{SS} = AV_{SS0} = V_{SS_USB} = 0\text{ V}$, $T_a = -40\text{ to }+105^\circ\text{C}$

Item		Symbol	Min.	Typ.	Max.	Unit	Test Conditions
Input pull-up resistor	All ports (except for port P35, port PH7)	R_U	10	20	100	k Ω	$V_{in} = 0\text{ V}$

[128-Kbyte or less flash memory]

Table 5.7 DC Characteristics (5) (1/2)Conditions: $1.8\text{ V} \leq \text{VCC} = \text{VCC_USB} \leq 3.6\text{ V}$, $1.8\text{ V} \leq \text{AVSS0} \leq 3.6\text{ V}$, $\text{VSS} = \text{AVSS0} = \text{VSS_USB} = 0\text{ V}$, $T_a = -40\text{ to }+105^\circ\text{C}$

Item				Symbol	Typ *4	Max	Unit	Test Conditions	
Supply current*1	High-speed operating mode	Normal operating mode	No peripheral operation*2	ICLK = 32 MHz	I _{CC}	3.2	—	mA	
				ICLK = 16 MHz		2.2	—		
				ICLK = 8 MHz		1.7	—		
			All peripheral operation: Normal*3	ICLK = 32 MHz		10.6	—		
				ICLK = 16 MHz		6.1	—		
				ICLK = 8 MHz		3.7	—		
		All peripheral operation: Max.*3	ICLK = 32 MHz	—	24				
			Sleep mode	No peripheral operation*2	ICLK = 32 MHz	1.8	—		
					ICLK = 16 MHz	1.4	—		
		ICLK = 8 MHz			1.1	—			
		All peripheral operation: Normal*3	ICLK = 32 MHz	6.4	—				
			ICLK = 16 MHz	3.7	—				
	ICLK = 8 MHz		2.4	—					
	Deep sleep mode	No peripheral operation*2	ICLK = 32 MHz	1.2	—				
			ICLK = 16 MHz	1.0	—				
			ICLK = 8 MHz	0.90	—				
		All peripheral operation: Normal*3	ICLK = 32 MHz	4.6	—				
			ICLK = 16 MHz	2.8	—				
			ICLK = 8 MHz	1.8	—				
	Increase during flash rewrite*5					2.5	—		
	Middle-speed operating modes	Normal operating mode	No peripheral operation*6	ICLK = 12 MHz	I _{CC}	2.0	—	mA	
				ICLK = 8 MHz		1.3	—		
				ICLK = 1 MHz		0.75	—		
				All peripheral operation: Normal*7		ICLK = 12 MHz	4.9		—
ICLK = 8 MHz						3.5	—		
ICLK = 1 MHz						1.2	—		
All peripheral operation: Max.*7			ICLK = 12 MHz	—		11			
			Sleep mode	No peripheral operation*6		ICLK = 12 MHz	1.4		—
						ICLK = 8 MHz	0.85		—
ICLK = 1 MHz						0.65	—		
All peripheral operation: Normal*7				ICLK = 12 MHz		3.2	—		
				ICLK = 8 MHz		2.2	—		
		ICLK = 1 MHz		1.0	—				
Deep sleep mode		No peripheral operation*6	ICLK = 12 MHz	1.2	—				
			ICLK = 8 MHz	0.70	—				
			ICLK = 1 MHz	0.60	—				
		All peripheral operation: Normal*7	ICLK = 12 MHz	2.5	—				
			ICLK = 8 MHz	1.8	—				
			ICLK = 1 MHz	0.90	—				
Increase during flash rewrite*5					2.5	—			

Table 5.7 DC Characteristics (5) (2/2)Conditions: $1.8\text{ V} \leq VCC = VCC_USB \leq 3.6\text{ V}$, $1.8\text{ V} \leq AVSS0 \leq 3.6\text{ V}$, $VSS = AVSS0 = VSS_USB = 0\text{ V}$, $T_a = -40\text{ to }+105^\circ\text{C}$

Item				Symbol	Typ *4	Max	Unit	Test Conditions
Supply current*1	Low-speed operating mode	Normal operating mode	No peripheral operation*8	ICLK = 32.768 kHz	I _{CC}	4.0	—	μA
			All peripheral operation: Normal*9, *10	ICLK = 32.768 kHz		11.5	—	
			All peripheral operation: Max.*9, *10	ICLK = 32.768 kHz		—	40	
		Sleep mode	No peripheral operation*8	ICLK = 32.768 kHz		2.2	—	
			All peripheral operation: Normal*9	ICLK = 32.768 kHz		7.1	—	
		Deep sleep mode	No peripheral operation*8	ICLK = 32.768 kHz		1.8	—	
			All peripheral operation: Normal*9	ICLK = 32.768 kHz		5.3	—	

Note 1. Supply current values do not include output charge/discharge current from all pins. The values apply when internal pull-up MOSs are in the off state.

Note 2. Clock supply to the peripheral functions is stopped. This does not include BGO operation. The clock source is PLL. FCLK and PCLK are set to divided by 64.

Note 3. Clocks are supplied to the peripheral functions. This does not include BGO operation. The clock source is PLL. FCLK and PCLK are set to the same frequency as ICLK.

Note 4. Values when $VCC = 3.3\text{ V}$.

Note 5. This is the increase for programming or erasure of the ROM or E2 DataFlash during program execution.

Note 6. Clock supply to the peripheral functions is stopped. The clock source is PLL when ICLK = 12 MHz, and HOCO otherwise. FCLK and PCLK are set to divided by 64.

Note 7. Clocks are supplied to the peripheral functions. The clock source is PLL when ICLK = 12 MHz, and HOCO otherwise. FCLK and PCLK are set to the same frequency as ICLK.

Note 8. Clock supply to the peripheral functions is stopped. The clock source is the sub-clock oscillator. FCLK and PCLK are set to divided by 64.

Note 9. Clocks are supplied to the peripheral functions. The clock source is the sub-clock oscillator. FCLK and PCLK are set to the same frequency as ICLK.

Note 10. Values when the MSTPCRA.MSTPA17 bit (12-bit A/D converter module stop bit) is set to "transition to the module stop state is made".

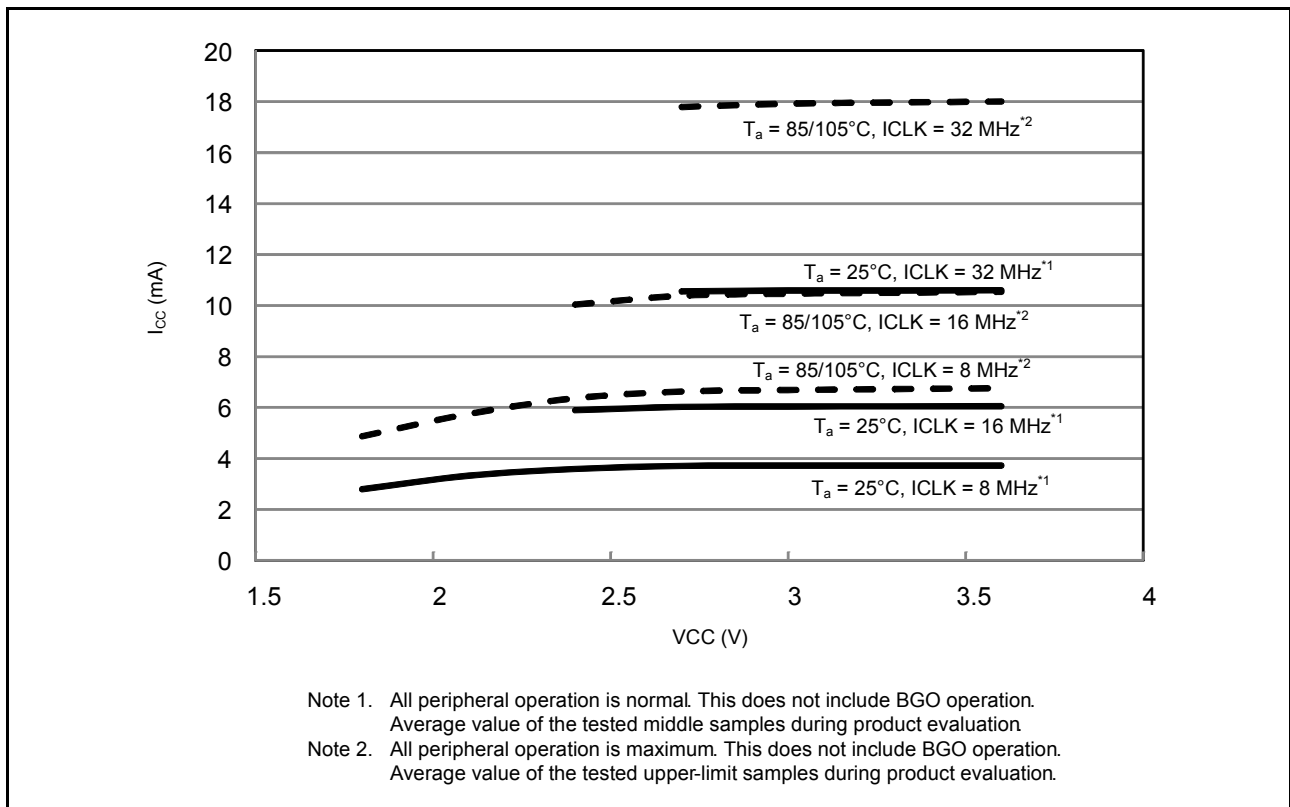

Figure 5.1 Voltage Dependency in High-Speed Operating Mode (Reference Data)

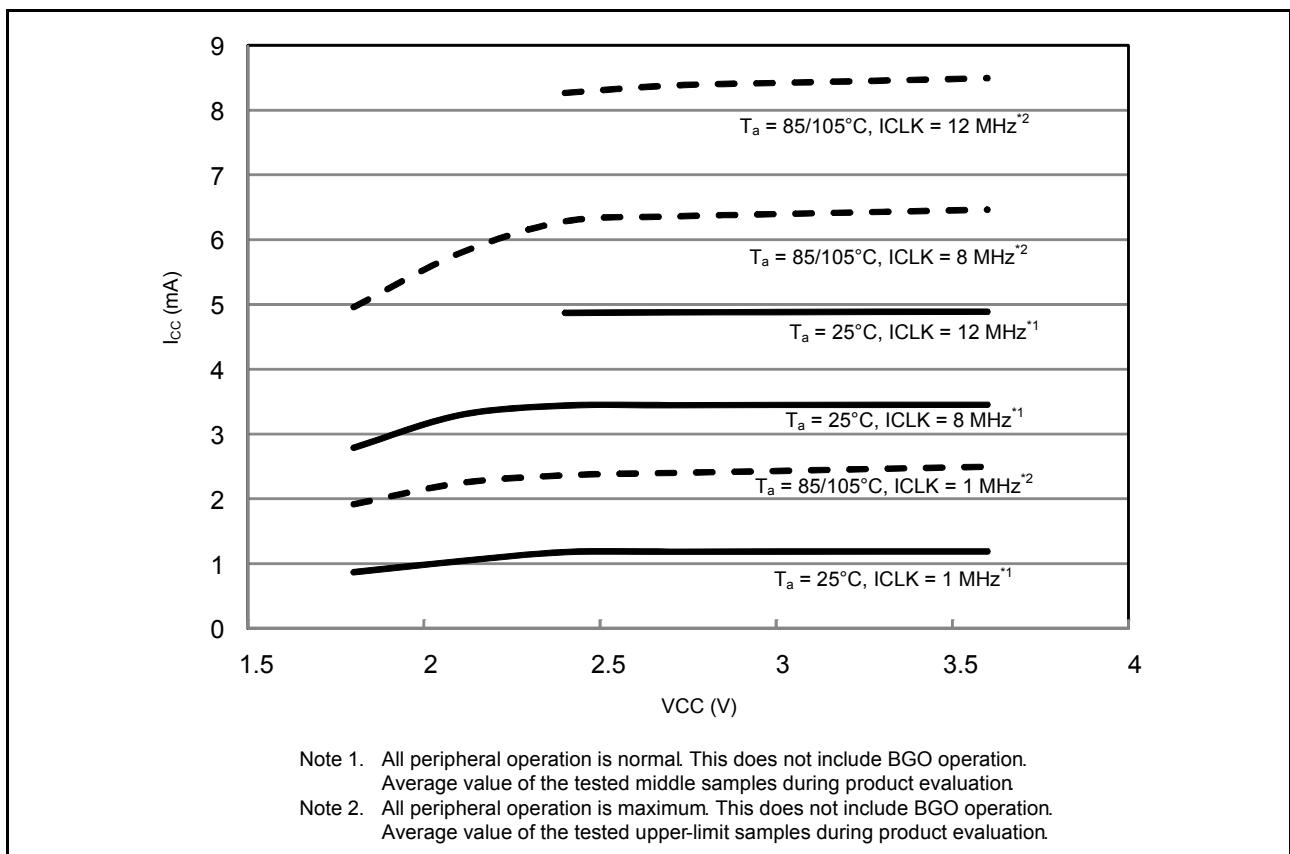

Figure 5.2 Voltage Dependency in Middle-Speed Operating Mode (Reference Data)

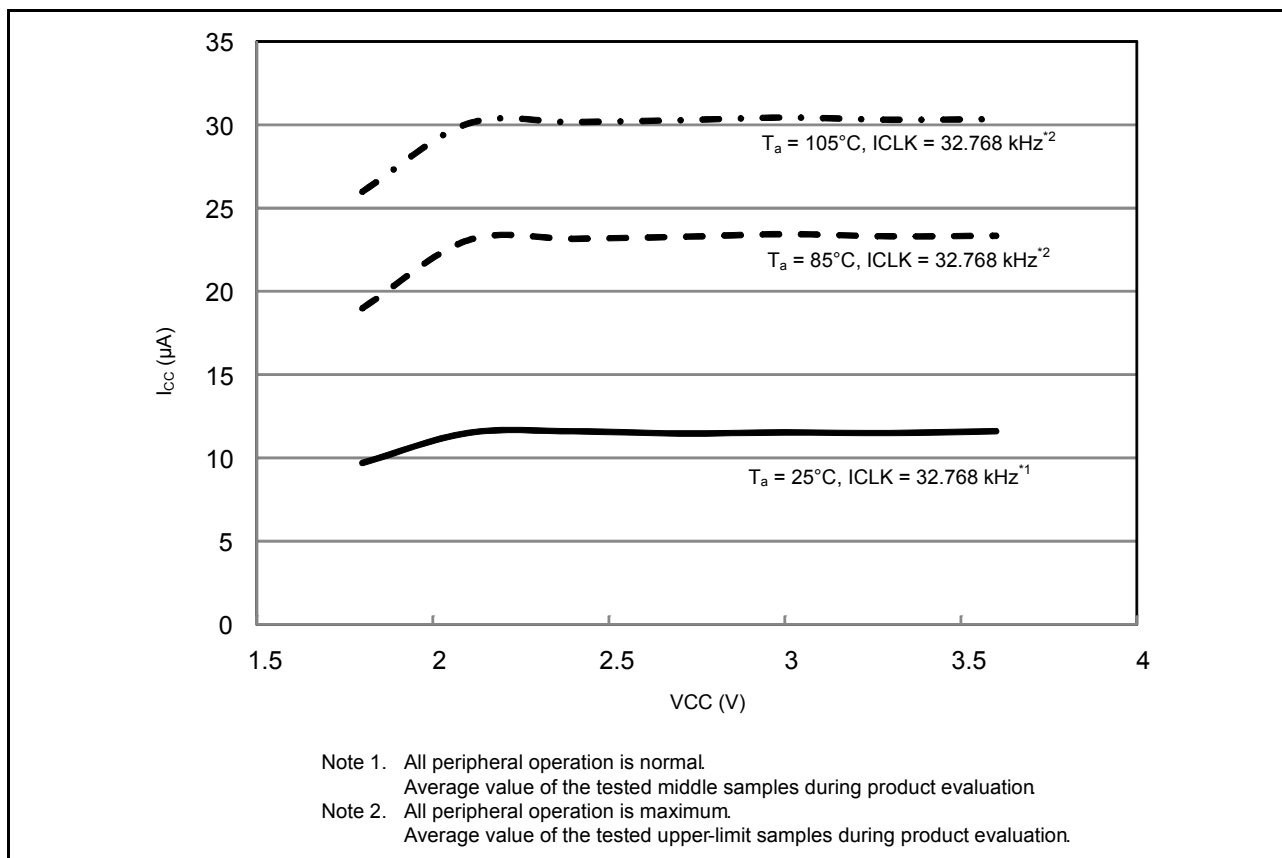

Figure 5.3 Voltage Dependency in Low-Speed Operating Mode (Reference Data)

[256-Kbyte or more flash memory]

Table 5.8 DC Characteristics (6) (1/2)

Conditions: 1.8 V ≤ VCC = VCC_USB ≤ 3.6 V, 1.8 V ≤ AVSS0 ≤ 3.6 V, VSS = AVSS0 = VSS_USB = 0 V, T_a = -40 to +105°C

Item				Symbol	Typ *4	Max	Unit	Test Conditions		
Supply current*1	High-speed operating mode	Normal operating mode	No peripheral operation*2	ICLK = 32 MHz	I _{CC}	3.6	—	mA		
				ICLK = 16 MHz		2.4	—			
				ICLK = 8 MHz		1.8	—			
			All peripheral operation: Normal*3	ICLK = 32 MHz		13.4	—			
				ICLK = 16 MHz		7.5	—			
				ICLK = 8 MHz		4.5	—			
			All peripheral operation: Max.*3	ICLK = 32 MHz		—	27			
			Sleep mode	No peripheral operation*2		ICLK = 32 MHz	1.9		—	
						ICLK = 16 MHz	1.5		—	
		ICLK = 8 MHz			1.3	—				
		All peripheral operation: Normal*3		ICLK = 32 MHz	7.6	—				
				ICLK = 16 MHz	4.4	—				
				ICLK = 8 MHz	2.8	—				
		Deep sleep mode	No peripheral operation*2	ICLK = 32 MHz	1.1	—				
				ICLK = 16 MHz	1.0	—				
	ICLK = 8 MHz			0.9	—					
	All peripheral operation: Normal*3		ICLK = 32 MHz	5.8	—					
			ICLK = 16 MHz	3.4	—					
			ICLK = 8 MHz	2.1	—					
	Increase during flash rewrite*5					2.5	—			
	Middle-speed operating modes	Normal operating mode	No peripheral operation*6	ICLK = 12 MHz	I _{CC}	2.1	—	mA		
				ICLK = 8 MHz					1.4	—
				ICLK = 1 MHz					0.8	—
				All peripheral operation: Normal*7					ICLK = 12 MHz	5.9
ICLK = 8 MHz									4.2	—
ICLK = 1 MHz									1.3	—
All peripheral operation: Max.*7			ICLK = 12 MHz	—					12.2	
Sleep mode			No peripheral operation*6	ICLK = 12 MHz					1.4	—
				ICLK = 8 MHz					0.9	—
				ICLK = 1 MHz					0.7	—
			All peripheral operation: Normal*7	ICLK = 12 MHz					3.6	—
				ICLK = 8 MHz					2.5	—
				ICLK = 1 MHz					1.1	—
Deep sleep mode			No peripheral operation*6	ICLK = 12 MHz					1.1	—
				ICLK = 8 MHz					0.6	—
		ICLK = 1 MHz		0.6	—					
		All peripheral operation: Normal*7	ICLK = 12 MHz	2.9	—					
			ICLK = 8 MHz	2.0	—					
			ICLK = 1 MHz	0.9	—					
Increase during flash rewrite*5					2.5	—				

Table 5.8 DC Characteristics (6) (2/2)Conditions: $1.8\text{ V} \leq VCC = VCC_USB \leq 3.6\text{ V}$, $1.8\text{ V} \leq AVSS0 \leq 3.6\text{ V}$, $VSS = AVSS0 = VSS_USB = 0\text{ V}$, $T_a = -40\text{ to }+105^\circ\text{C}$

Item					Symbol	Typ *4	Max	Unit	Test Conditions
Supply current*1	Low-speed operating mode	Normal operating mode	No peripheral operation*8	ICLK = 32.768 kHz	I _{CC}	4.3	—	μA	
			All peripheral operation: Normal*9, *10	ICLK = 32.768 kHz		14.7	—		
			All peripheral operation: Max.*9, *10	ICLK = 32.768kHz		—	60		
		Sleep mode	No peripheral operation*8	ICLK = 32.768 kHz		2.2	—		
			All peripheral operation: Normal*9	ICLK = 32.768 kHz		8.3	—		
		Deep sleep mode	No peripheral operation*8	ICLK = 32.768 kHz		1.7	—		
			All peripheral operation: Normal*9	ICLK = 32.768 kHz		6.7	—		

Note 1. Supply current values do not include output charge/discharge current from all pins. The values apply when internal pull-up MOSs are in the off state.

Note 2. Clock supply to the peripheral functions is stopped. This does not include BGO operation. The clock source is PLL. FCLK and PCLK are set to divided by 64.

Note 3. Clocks are supplied to the peripheral functions. This does not include BGO operation. The clock source is PLL. FCLK and PCLK are set to the same frequency as ICLK.

Note 4. Values when $VCC = 3.3\text{ V}$.

Note 5. This is the increase for programming or erasure of the ROM or E2 DataFlash during program execution.

Note 6. Clock supply to the peripheral functions is stopped. The clock source is PLL when ICLK = 12 MHz, and HOCO otherwise. FCLK and PCLK are set to divided by 64.

Note 7. Clocks are supplied to the peripheral functions. The clock source is PLL when ICLK = 12 MHz, and HOCO otherwise. FCLK and PCLK are set to the same frequency as ICLK.

Note 8. Clock supply to the peripheral functions is stopped. The clock source is the sub-clock oscillator. FCLK and PCLK are set to divided by 64.

Note 9. Clocks are supplied to the peripheral functions. The clock source is the sub-clock oscillator. FCLK and PCLK are set to the same frequency as ICLK.

Note 10. Values when the MSTPCRA.MSTPA17 bit (12-bit A/D converter module stop bit) is set to "transition to the module stop state is made".



Figure 5.4 Voltage Dependency in High-Speed Operating Mode (Reference Data)

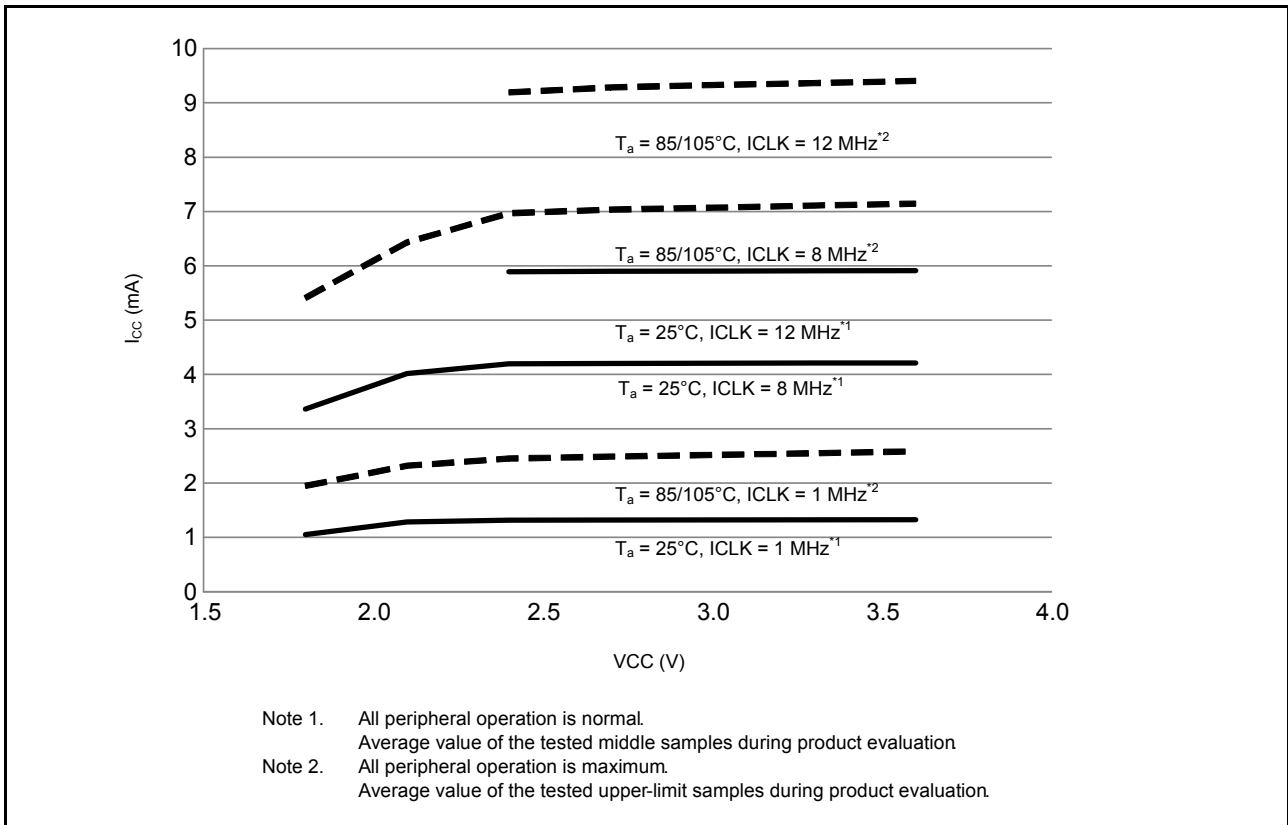

Figure 5.5 Voltage Dependency in Middle-Speed Operating Mode (Reference Data)

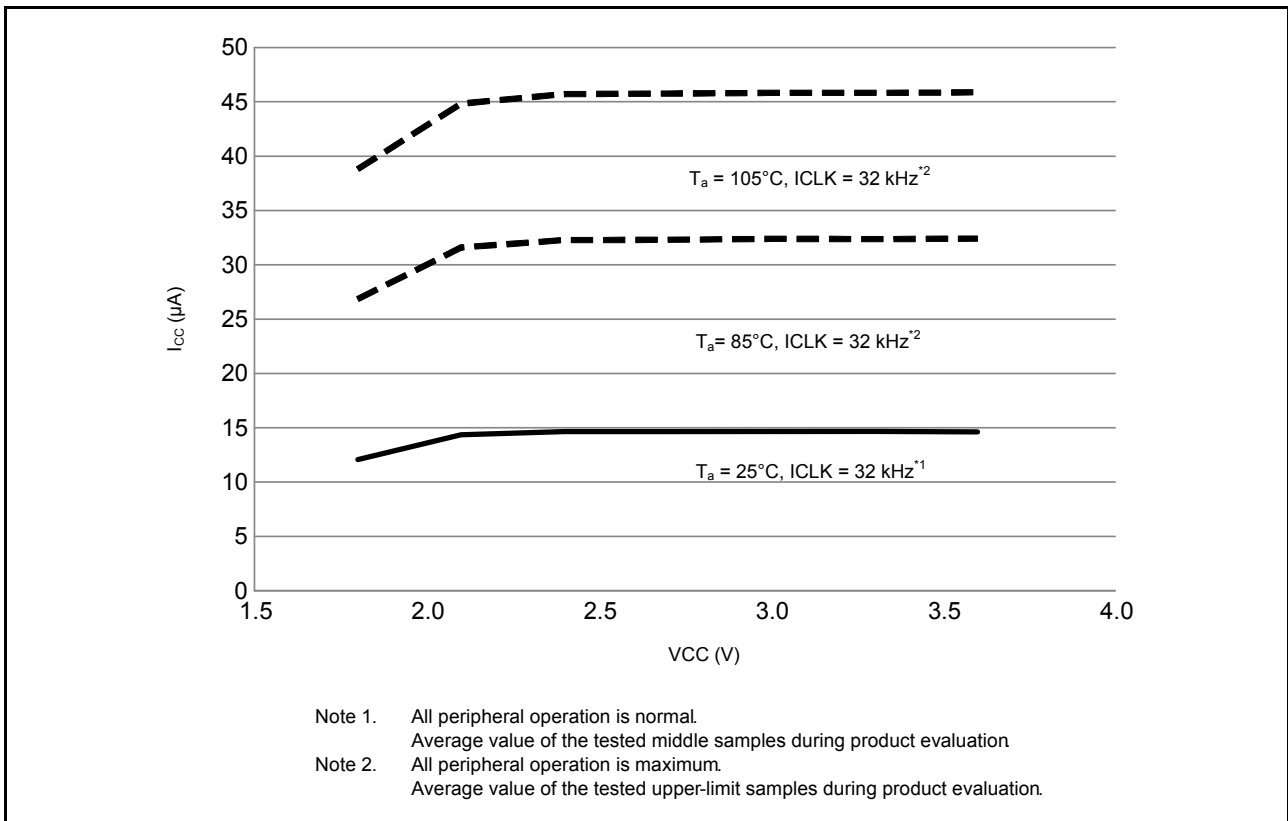

Figure 5.6 Voltage Dependency in Low-Speed Operating Mode (Reference Data)

[128-Kbyte or less flash memory]

Table 5.9 DC Characteristics (7)

Conditions: $1.8\text{ V} \leq VCC = VCC_USB \leq 3.6\text{ V}$, $1.8\text{ V} \leq AVSS0 \leq 3.6\text{ V}$, $VSS = AVSS0 = VSS_USB = 0\text{ V}$, $T_a = -40\text{ to }+105^\circ\text{C}$

Item		Symbol	Typ.*3	Max.	Unit	Test Conditions	
Supply current*1	Software standby mode*2	I_{CC}	$T_a = 25^\circ\text{C}$	0.35	0.53	μA	RCR3.RTCDV[2:0] = 010b RCR3.RTCDV[2:0] = 100b
			$T_a = 55^\circ\text{C}$	0.58	1.45		
			$T_a = 85^\circ\text{C}$	1.60	7.30		
			$T_a = 105^\circ\text{C}$	3.30	16.50		
	Increment for RTC operation*4		0.31	—			
	Increment for IWDT operation		1.09	—			
			0.37	—			

Note 1. Supply current values do not include output charge/discharge current from all pins. The values apply when internal pull-up MOSs are in the off state.

Note 2. The IWDT and LVD are stopped.

Note 3. $VCC = 3.3\text{ V}$.

Note 4. Includes the oscillation circuit.



Figure 5.7 Voltage Dependency in Software Standby Mode (Reference Data)



Figure 5.8 Temperature Dependency in Software Standby Mode (Reference Data)

[256-Kbyte or more flash memory]

Table 5.10 DC Characteristics (8)

Conditions: $1.8\text{ V} \leq VCC = VCC_USB \leq 3.6\text{ V}$, $1.8\text{ V} \leq AVSS0 \leq 3.6\text{ V}$, $VSS = AVSS0 = VSS_USB = 0\text{ V}$, $T_a = -40\text{ to }+105^\circ\text{C}$

Item		Symbol	Typ.*3	Max.	Unit	Test Conditions	
Supply current*1	Software standby mode*2	I_{CC}	$T_a = 25^\circ\text{C}$	0.44	0.98	μA	RCR3.RTCDV[2:0] = 010b RCR3.RTCDV[2:0] = 100b
			$T_a = 55^\circ\text{C}$	0.80	3.47		
			$T_a = 85^\circ\text{C}$	2.7	12.0		
			$T_a = 105^\circ\text{C}$	6.17	42.7		
	Increment for RTC operation*4		0.31	—			
	Increment for IWDT operation		1.09	—			
			0.37	—			

Note 1. Supply current values do not include output charge/discharge current from all pins. The values apply when internal pull-up MOSs are in the off state.

Note 2. The IWDT and LVD are stopped.

Note 3. $VCC = 3.3\text{ V}$.

Note 4. Includes the oscillation circuit.

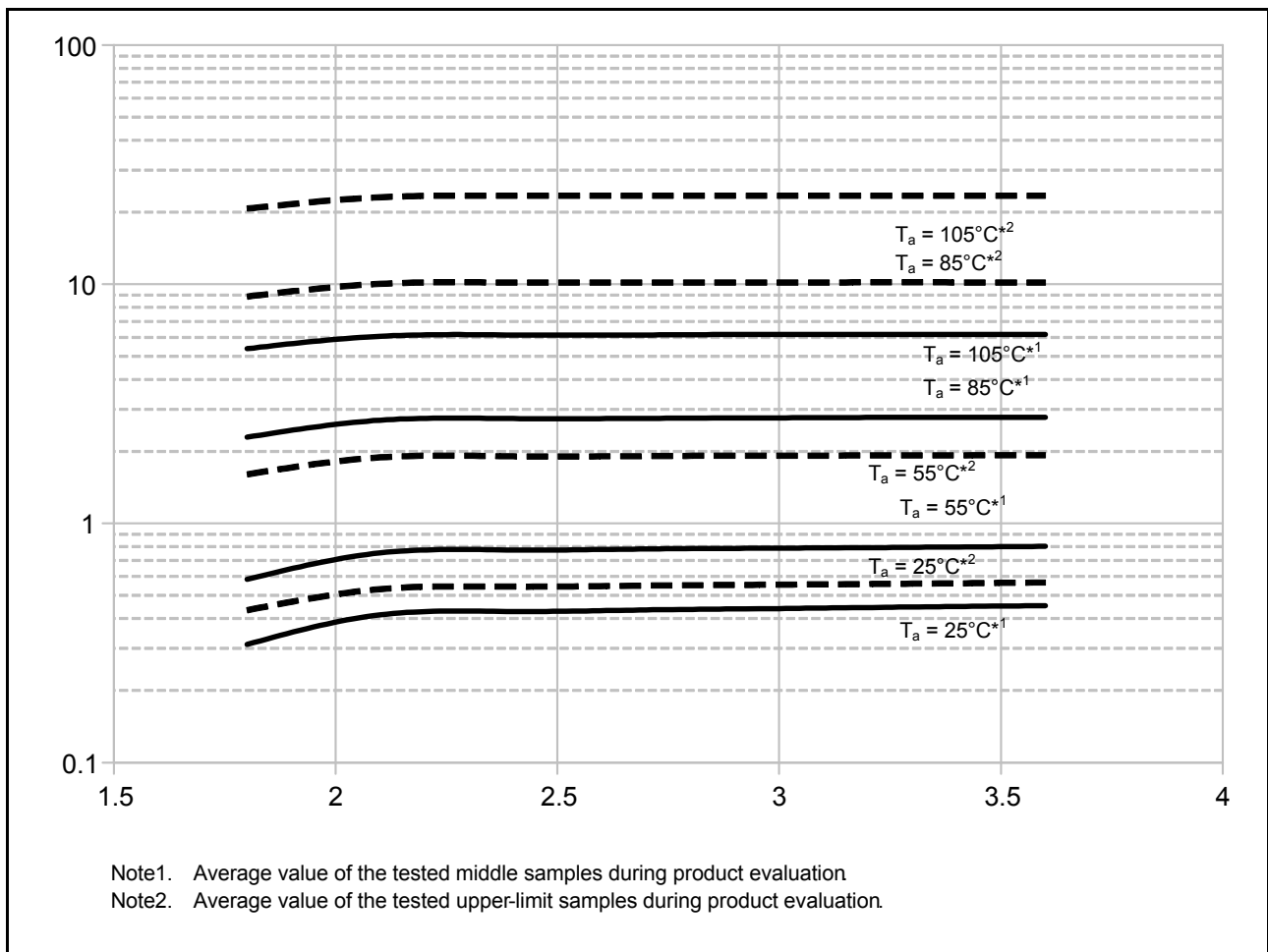

Figure 5.9 Voltage Dependency in Software Standby Mode (Reference Data)

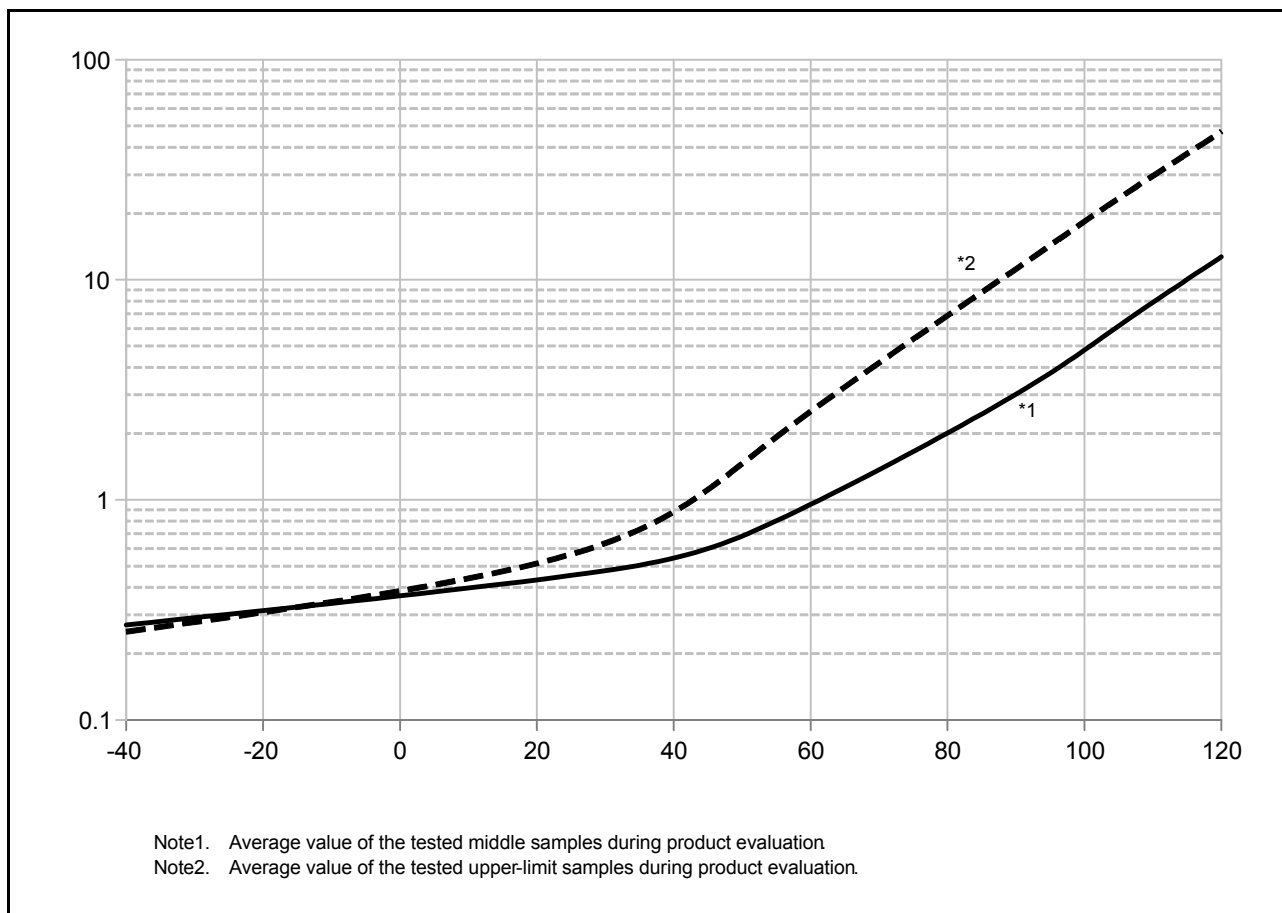

Figure 5.10 Temperature Dependency in Software Standby Mode (Reference Data)

Table 5.11 DC Characteristics (9)

Conditions: 1.8 V ≤ VCC = VCC_USB ≤ 3.6 V, 1.8 V ≤ AVCC0 ≤ 3.6 V, VSS = AVSS0 = VSS_USB = 0 V

Item	Symbol	Typ.	Max.	Unit	Test Conditions
Permissible total consumption power*1	Pd	—	300	mW	D version (T _a = -40 to 85°C)
		—	105		G version (T _a = -40 to 105°C)*2

Note 1. Total power dissipated by the entire chip (including output currents).

Note 2. Please contact Renesas Electronics sales office for derating under T_a = +85°C to 105°C. Derating is the systematic reduction of load for the sake of improved reliability.

Table 5.12 DC Characteristics (10)Conditions: $1.8\text{ V} \leq VCC = VCC_USB \leq 3.6\text{ V}$, $1.8\text{ V} \leq AVSS0 \leq 3.6\text{ V}$, $VSS = AVSS0 = VSS_USB = 0\text{ V}$, $T_a = -40\text{ to }+105^\circ\text{C}$

Item		Symbol	Min.	Typ.*7	Max.	Unit	Test Conditions
Analog power supply current	During A/D conversion (at high-speed conversion)	I_{AVCC}	—	0.7	1.2	mA	
	Waiting for A/D (all units)		—	—	0.3	μA	
	During D/A conversion (per channel)*5		—	—	1.5	mA	
Reference power supply current	During A/D conversion (at high-speed conversion)	I_{REFH0}	—	25	52	μA	
	Waiting for A/D conversion (all units)		—	—	60	nA	
Temperature sensor*6		I_{TEMP}	—	75	—	μA	
LDV1, 2	Per channel	I_{LVD}	—	0.15	—	μA	
USB operating current	During USB communication operation under the following settings and conditions <ul style="list-style-type: none"> Host controller operation is set to full-speed mode Bulk OUT transfer (64 bytes) \times 1, bulk IN transfer (64 bytes) \times 1 Connect peripheral devices via a 1-meter USB cable from the USB port. 	I_{USBH} *2	—	4.3 (VCC) 0.9 (VCC_USB) *4	—	mA	
	During USB communication operation under the following settings and conditions <ul style="list-style-type: none"> Function controller operation is set to full-speed mode Bulk OUT transfer (64 bytes) \times 1, bulk IN transfer (64 bytes) \times 1 Connect the host device via a 1-meter USB cable from the USB port. 	I_{USBF} *2	—	3.6 (VCC) 1.1 (VCC_USB) *4	—	mA	
	During suspended state under the following setting and conditions <ul style="list-style-type: none"> Function controller operation is set to full-speed mode (pull up the USB0_DP pin) Software standby mode Connect the host device via a 1-meter USB cable from the USB port. 	I_{SUSP} *3	—	0.35 (VCC) 170 (VCC_USB) *4	—	μA	

Note 1. The reference power supply current is included in the power supply current value for D/A conversion.

Note 2. Current consumed only by the USB module.

Note 3. Includes the current supplied from the pull-up resistor of the USB0_DP pin to the pull-down resistor of the host device, in addition to the current consumed by this MCU during the suspended state.

Note 4. When $VCC = VCC_USB = 3.3\text{ V}$.

Note 5. The value of the current flowing to VCC.

Note 6. Current consumed by the power supply (VCC).

Note 7. When $VCC = AVCC0 = VCC_USB = 3.3\text{ V}$.**Table 5.13 DC Characteristics (11)**Conditions: $1.8\text{ V} \leq VCC = VCC_USB \leq 3.6\text{ V}$, $1.8\text{ V} \leq AVSS0 \leq 3.6\text{ V}$, $VSS = AVSS0 = VSS_USB = 0\text{ V}$, $T_a = -40\text{ to }+105^\circ\text{C}$

Item	Symbol	Min.	Typ.	Max.	Unit	Test Conditions
RAM standby voltage	V_{RAM}	1.8	—	—	V	

Table 5.14 DC Characteristics (12)

Conditions: $0\text{ V} \leq \text{VCC} = \text{VCC_USB} \leq 3.6\text{ V}$, $\text{VSS} = \text{AVSS0} = \text{VSS_USB} = 0\text{ V}$, $T_a = -40\text{ to }+105^\circ\text{C}$

Item		Symbol	Min.	Typ.	Max.	Unit	Test Conditions
Power-on VCC rising gradient	At normal startup*1	SrVCC	0.02	—	20	ms/V	
	During fast startup time*2		0.02	—	2		
	Voltage monitoring 1 reset enabled at startup*3, *4		0.02	—	—		

Note: When powering on AVCC0 and VCC, power them on at the same time or VCC first.

Note 1. When OFS1.(STUPLVD1REN, FASTSTUP) = 11b.

Note 2. When OFS1.(STUPLVD1REN, FASTSTUP) = 10b.

Note 3. When OFS1.STUPLVD1REN = 0.

Note 4. Turn on the power supply voltage according to the normal startup rising gradient because the register settings set by OFS1 are not read in boot mode.

Table 5.15 DC Characteristics (13)

Conditions: $1.8\text{ V} \leq \text{VCC} = \text{VCC_USB} \leq 3.6\text{ V}$, $1.8\text{ V} \leq \text{AVSS0} \leq 3.6\text{ V}$, $\text{VSS} = \text{AVSS0} = \text{VSS_USB} = 0\text{ V}$, $T_a = -40\text{ to }+105^\circ\text{C}$

The ripple voltage must meet the allowable ripple frequency $f_{r(\text{VCC})}$ within the range between the VCC upper limit (3.6 V) and lower limit (1.8 V).

When VCC change exceeds $\text{VCC} \pm 10\%$, the allowable voltage change rising/falling gradient $dt/d\text{VCC}$ must be met.

Item	Symbol	Min.	Typ.	Max.	Unit	Test Conditions
Allowable ripple frequency	$f_{r(\text{VCC})}$	—	—	10	kHz	Figure 5.11 $V_{r(\text{VCC})} \leq \text{VCC} \times 0.2$
		—	—	1	MHz	Figure 5.11 $V_{r(\text{VCC})} \leq \text{VCC} \times 0.08$
		—	—	10	MHz	Figure 5.11 $V_{r(\text{VCC})} \leq \text{VCC} \times 0.06$
Allowable voltage change rising/falling gradient	$dt/d\text{VCC}$	1.0	—	—	ms/V	When VCC change exceeds $\text{VCC} \pm 10\%$



Figure 5.11 Ripple Waveform

Table 5.16 DC Characteristics (14)

Conditions: $1.8\text{ V} \leq \text{VCC} = \text{VCC_USB} \leq 3.6\text{ V}$, $1.8\text{ V} \leq \text{AVSS0} \leq 3.6\text{ V}$, $\text{VSS} = \text{AVSS0} = \text{VSS_USB} = 0\text{ V}$, $T_a = -40\text{ to }+105^\circ\text{C}$

Item	Symbol	Min.	Typ.	Max.	Unit	Test Conditions
Permissible error of VCL pin external capacitance	C_{VCL}	1.4	4.7	7.0	μF	

Note: • The recommended capacitance is 4.7 μF . Variations in connected capacitors should be within the above range.

Table 5.17 Permissible Output Currents (1)

Conditions: $1.8\text{ V} \leq V_{CC} = V_{CC_USB} \leq 3.6\text{ V}$, $1.8\text{ V} \leq AV_{CC0} \leq 3.6\text{ V}$, $V_{SS} = AV_{SS0} = V_{SS_USB} = 0\text{ V}$,
 $T_a = -40\text{ to }+85^\circ\text{C}$ (D version)

	Item	Symbol	Max.	Unit
Permissible output low current (average value per pin)	Ports P40 to P44, P46, ports PJ6, PJ7	I_{OL}	0.4	mA
	Ports other than above		8.0	
Permissible output low current (maximum value per pin)	Ports P40 to P44, P46, ports PJ6, PJ7		0.4	
	Ports other than above		8.0	
Permissible output low current	Total of ports P40 to P44, P46, ports PJ6, PJ7	ΣI_{OL}	2.4	
	Total of ports P03, P05, ports P26, P27, ports P30, P31		30	
	Total of ports P14 to P17, port P32, ports P54, P55, ports PB0, PB1, PB3, PB5 to PB7, ports PC2 to PC7		30	
	Total of ports PA0, PA1, PA3, PA4, PA6, ports PE0 to PE7		30	
	Total of all output pins		60	
Permissible output high current (average value per pin)	Ports P40 to P44, P46, ports PJ6, PJ7	I_{OH}	-0.1	
	Ports other than above		-4.0	
Permissible output high current (maximum value per pin)	Ports P40 to P44, P46, ports PJ6, PJ7		-0.1	
	Ports other than above		-4.0	
Permissible output high current	Total of ports P40 to P44, P46, ports PJ6, PJ7	ΣI_{OH}	-0.6	
	Total of ports P03, P05, ports P26, P27, ports P30, P31		-10	
	Total of ports P14 to P17, port P32, ports P54, P55, ports PB0, PB1, PB3, PB5 to PB7, ports PC2 to PC7		-15	
	Total of ports PA0, PA1, PA3, PA4, PA6, ports PE0 to PE7		-15	
	Total of all output pins		-40	

Note: Do not exceed the permissible total supply current.

Table 5.18 Permissible Output Currents (2)

Conditions: $1.8\text{ V} \leq V_{CC} = V_{CC_USB} \leq 3.6\text{ V}$, $1.8\text{ V} \leq AV_{CC0} \leq 3.6\text{ V}$, $V_{SS} = AV_{SS0} = V_{SS_USB} = 0\text{ V}$,
 $T_a = -40\text{ to }+105^\circ\text{C}$ (G version)

	Item	Symbol	Max.	Unit
Permissible output low current (average value per pin)	Ports P40 to P44, P46, ports PJ6, PJ7	I_{OL}	0.4	mA
	Ports other than above		8.0	
Permissible output low current (maximum value per pin)	Ports P40 to P44, P46, ports PJ6, PJ7		0.4	
	Ports other than above		8.0	
Permissible output low current	Total of ports P40 to P44, P46, ports PJ6, PJ7	ΣI_{OL}	1.6	
	Total of ports P03, P05, ports P26, P27, ports P30, P31		20	
	Total of ports P14 to P17, port P32, ports P54, P55, ports PB0, PB1, PB3, PB5 to PB7, ports PC2 to PC7		20	
	Total of ports PA0, PA1, PA3, PA4, PA6, ports PE0 to PE7		20	
	Total of all output pins		40	
Permissible output high current (average value per pin)	Ports P40 to P44, P46, ports PJ6, PJ7	I_{OH}	-0.1	
	Ports other than above		-4.0	
Permissible output high current (maximum value per pin)	Ports P40 to P44, P46, ports PJ6, PJ7		-0.1	
	Ports other than above		-4.0	
Permissible output high current	Total of ports P40 to P44, P46, ports PJ6, PJ7	ΣI_{OH}	-0.6	
	Total of ports P03, P05, ports P26, P27, ports P30, P31		-10	
	Total of ports P14 to P17, port P32, ports P54, P55, ports PB0, PB1, PB3, PB5 to PB7, ports PC2 to PC7		-15	
	Total of ports PA0, PA1, PA3, PA4, PA6, ports PE0 to PE7		-15	
	Total of all output pins		-40	

Note: Do not exceed the permissible total supply current.

Table 5.19 Output Voltage (1)Conditions: $2.7\text{ V} \leq V_{CC} = V_{CC_USB} \leq 3.6\text{ V}$, $2.7\text{ V} \leq AV_{SS0} \leq 3.6\text{ V}$, $V_{SS} = AV_{SS0} = V_{SS_USB} = 0\text{ V}$, $T_a = -40\text{ to }+105^\circ\text{C}$

Item		Symbol	Min.	Max.	Unit	Test Conditions	
Low-level output voltage	All output ports (except for RIIC, ports P40 to P44, P46, ports PJ6, PJ7)	V_{OL}	—	0.6	V	$I_{OL} = 3.0\text{ mA}$	
			—	0.4		$I_{OL} = 1.5\text{ mA}$	
	Ports P40 to P44, P46, ports PJ6, PJ7		—	0.4		$I_{OL} = 0.4\text{ mA}$	
	RIIC pins		Standard mode	—		0.4	$I_{OL} = 3.0\text{ mA}$
			Fast mode	—		0.6	$I_{OL} = 6.0\text{ mA}$
High-level output voltage	All output ports (except for ports P40 to P44, P46, ports PJ6, PJ7)	V_{OH}	$V_{CC} - 0.5$	—	V	$I_{OH} = -2.0\text{ mA}$	
	Ports P40 to P44, P46, ports PJ6, PJ7		$AV_{CC0} - 0.5$	—		$I_{OH} = -0.1\text{ mA}$	

Table 5.20 Output Voltage (2)Conditions: $1.8\text{ V} \leq V_{CC} = V_{CC_USB} \leq 2.7\text{ V}$, $1.8\text{ V} \leq AV_{SS0} \leq 2.7\text{ V}$, $V_{SS} = AV_{SS0} = V_{SS_USB} = 0\text{ V}$, $T_a = -40\text{ to }+105^\circ\text{C}$

Item		Symbol	Min.	Max.	Unit	Test Conditions
Low-level output voltage	All output ports (except for ports P40 to P44, P46, ports PJ6, PJ7)	V_{OL}	—	0.6	V	$I_{OL} = 1.5\text{ mA}$
	Ports P40 to P44, P46, ports PJ6, PJ7		—	0.4		$I_{OL} = 0.4\text{ mA}$
High-level output voltage	All output ports (except for ports P40 to P44, P46, ports PJ6, PJ7)	V_{OH}	$V_{CC} - 0.5$	—	V	$I_{OH} = -1.0\text{ mA}$
	Ports P40 to P44, P46, ports PJ6, PJ7		$AV_{CC0} - 0.5$	—		$I_{OH} = -0.1\text{ mA}$

5.2.1 Standard I/O Pin Output Characteristics (1)

Figure 5.12 to Figure 5.15 show the characteristics of general ports (except for the RIIC output pin, ports P40 to P44, P46, ports PJ6, PJ7)



Figure 5.12 V_{OH}/V_{OL} and I_{OH}/I_{OL} Voltage Characteristics of General Ports (Except for the RIIC Output Pin, Ports P40 to P44, P46, Ports PJ6, PJ7) at $T_a = 25^\circ\text{C}$ (Reference Data)



Figure 5.13 V_{OH}/V_{OL} and I_{OH}/I_{OL} Temperature Characteristics of General Ports (Except for the RIIC Output Pin, Ports P40 to P44, P46, Ports PJ6, PJ7) at $V_{CC} = 1.8\text{ V}$ (Reference Data)

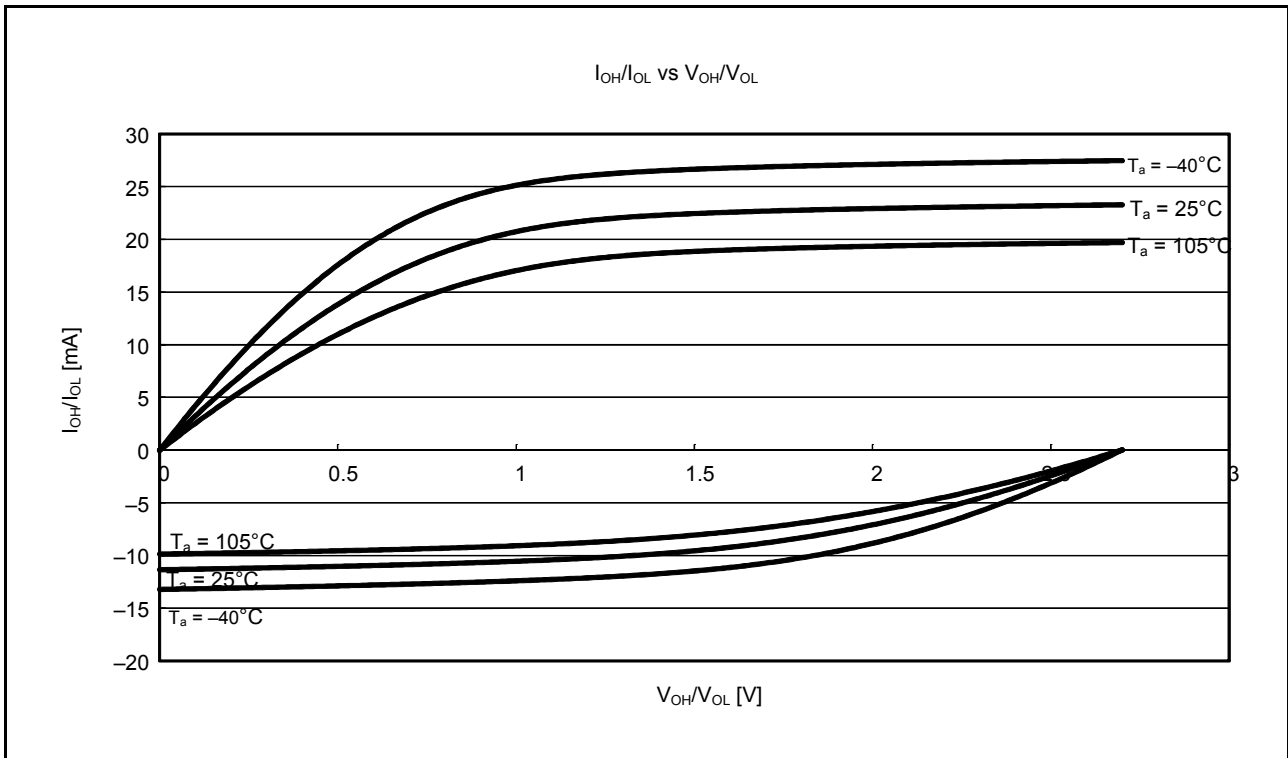

Figure 5.14 V_{OH}/V_{OL} and I_{OH}/I_{OL} Temperature Characteristics of General Ports (Except for the RIIC Output Pin, Ports P40 to P44, P46, Ports PJ6, PJ7) at $V_{CC} = 2.7$ V (Reference Data)



Figure 5.15 V_{OH}/V_{OL} and I_{OH}/I_{OL} Temperature Characteristics of General Ports (Except for the RIIC Output Pin, Ports P40 to P44, P46, Ports PJ6, PJ7) at $V_{CC} = 3.3$ V (Reference Data)

5.2.2 Standard I/O Pin Output Characteristics (2)

Figure 5.16 to Figure 5.18 show the characteristics of the RIIC output pin.

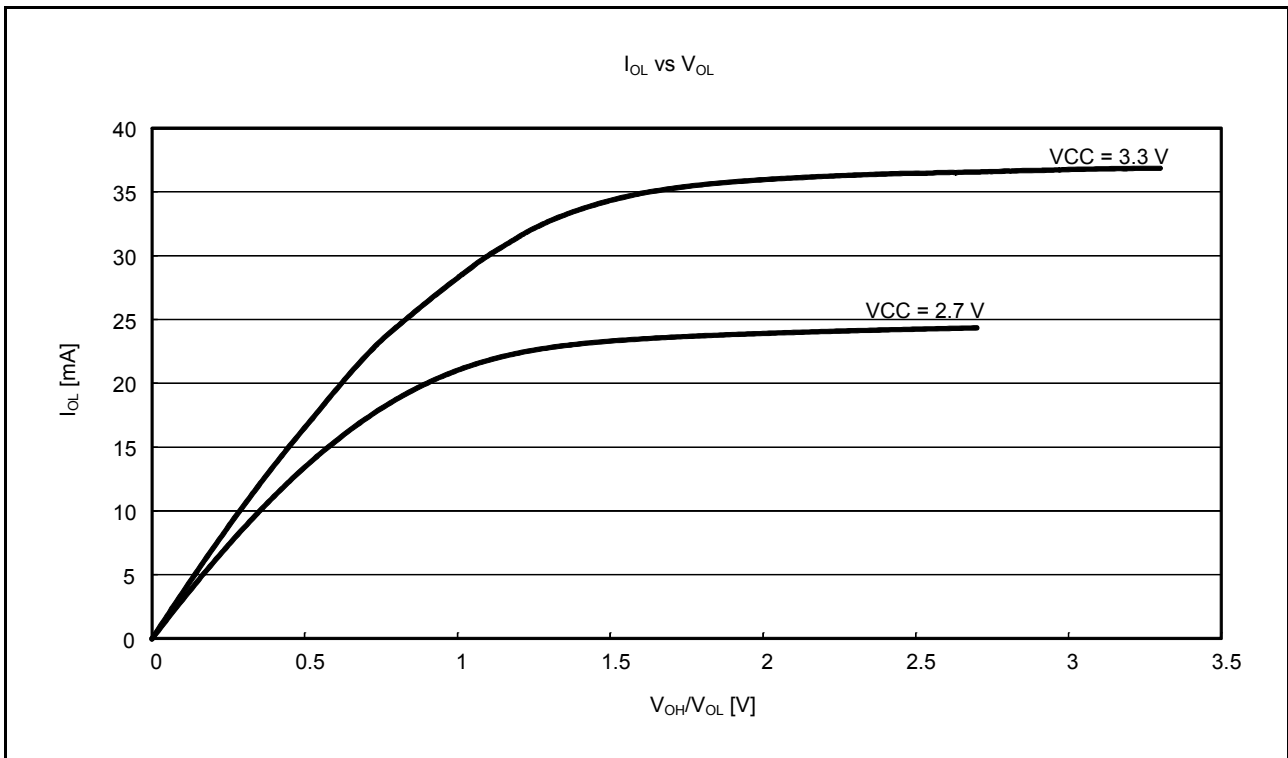

Figure 5.16 V_{OL} and I_{OL} Voltage Characteristics of RIIC Output Pin at T_a = 25°C (Reference Data)

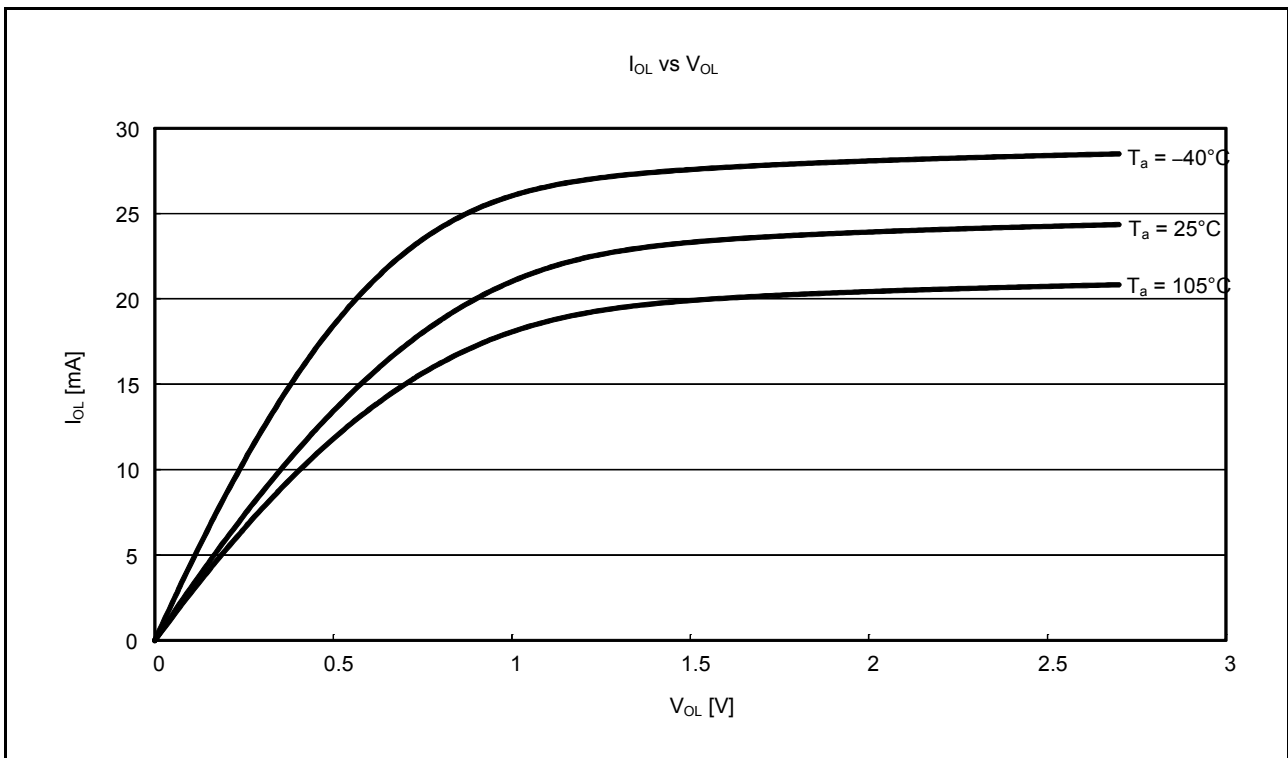

Figure 5.17 V_{OL} and I_{OL} Temperature Characteristics of RIIC Output Pin at VCC = 2.7 V (Reference Data)

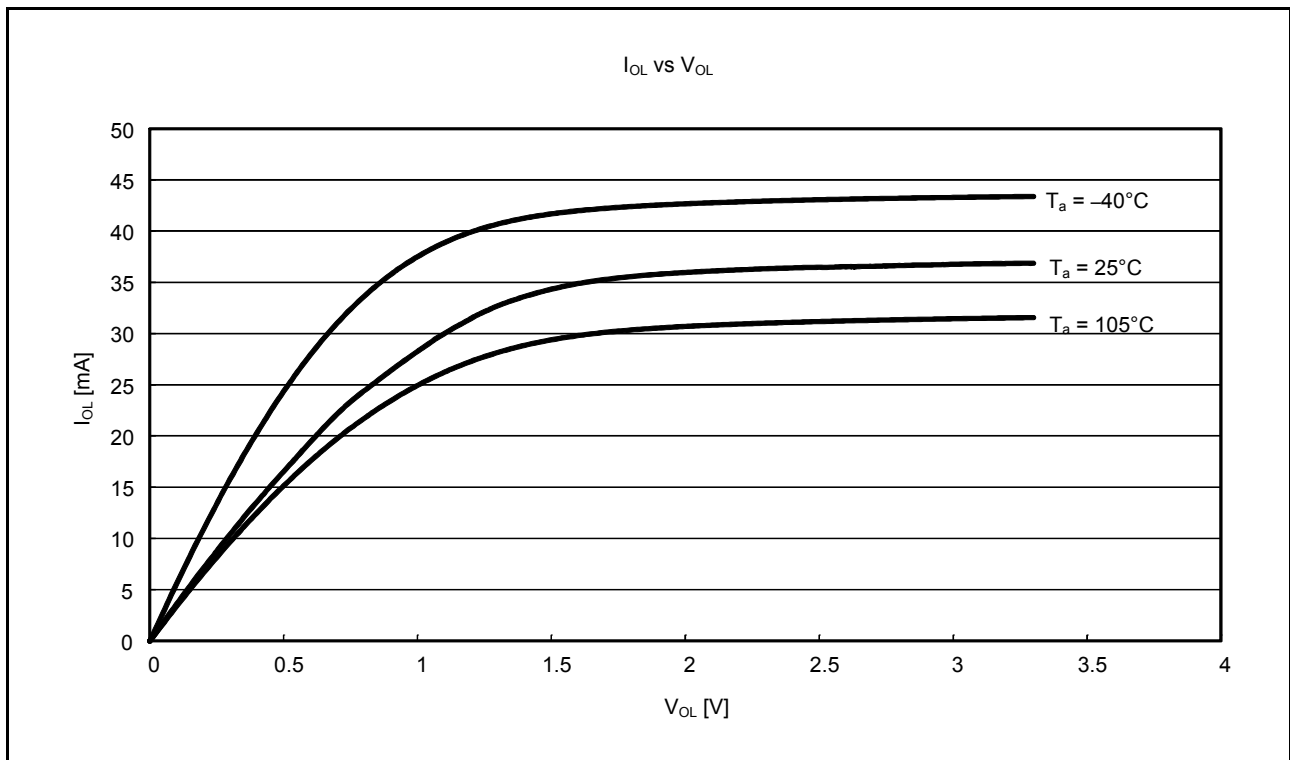

Figure 5.18 V_{OL} and I_{OL} Temperature Characteristics of RIIC Output Pin at VCC = 3.3 V (Reference Data)

5.2.3 Standard I/O Pin Output Characteristics (3)

Figure 5.19 to Figure 5.22 show the characteristics of ports P40 to P44, P46, ports PJ6, PJ7.



Figure 5.19 V_{OH}/V_{OL} and I_{OH}/I_{OL} Voltage Characteristics of Ports P40 to P44, P46, Ports PJ6, PJ7 at $T_a = 25^\circ\text{C}$ (Reference Data)

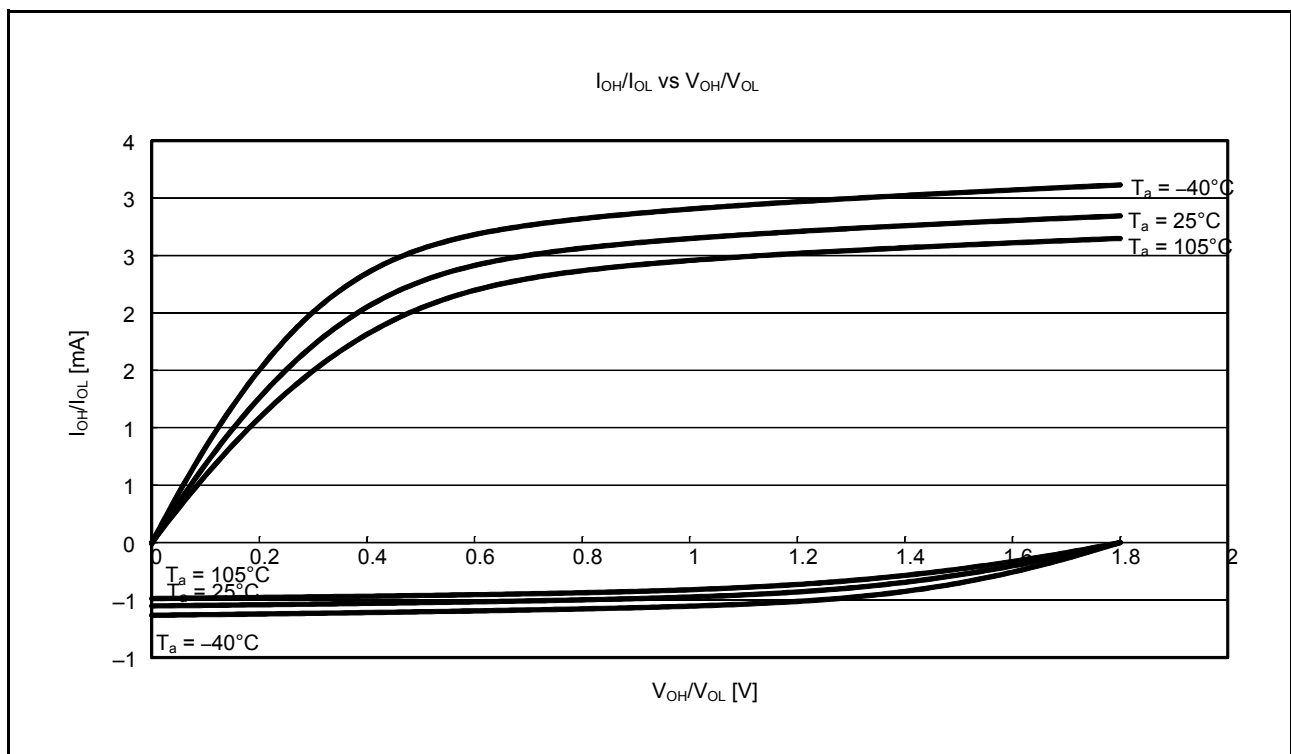

Figure 5.20 V_{OH}/V_{OL} and I_{OH}/I_{OL} Temperature Characteristics of Ports P40 to P44, P46, Ports PJ6, PJ7 at $V_{CC} = 1.8\text{ V}$ (Reference Data)

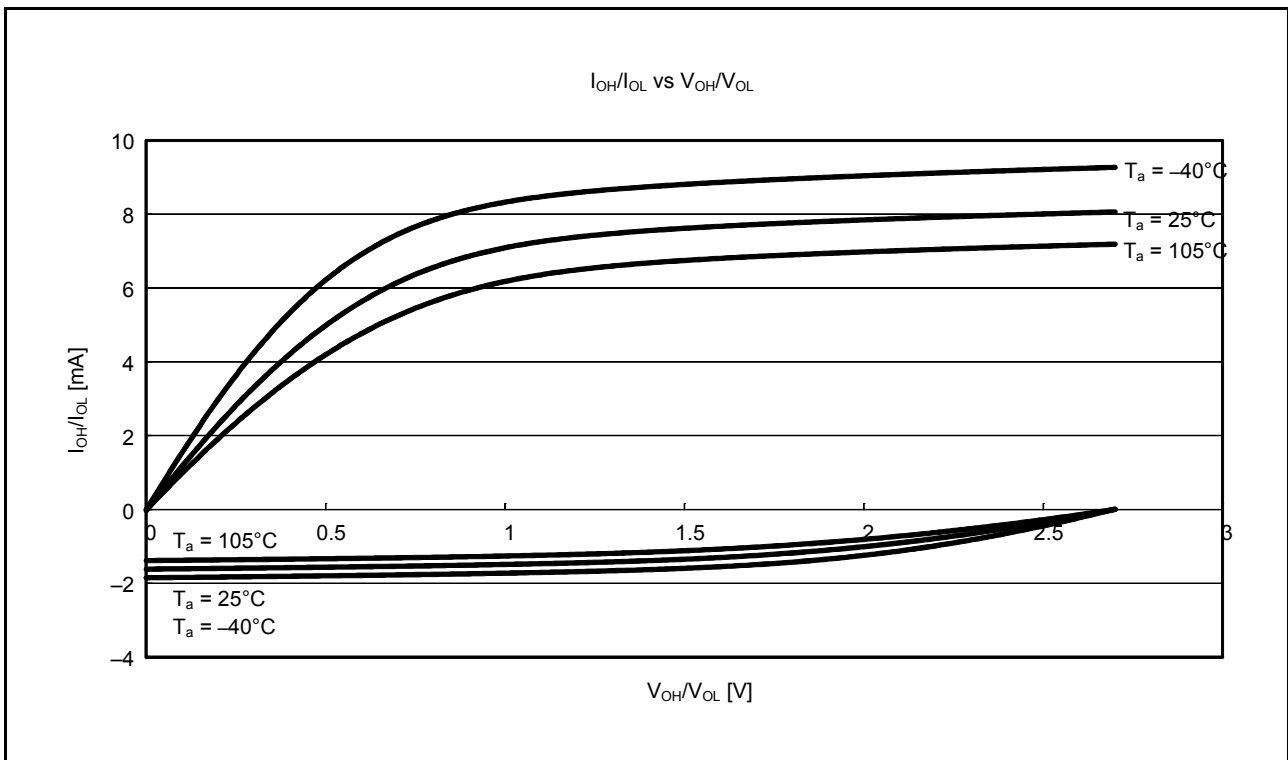

Figure 5.21 V_{OH}/V_{OL} and I_{OH}/I_{OL} Temperature Characteristics of Ports P40 to P44, P46, Ports PJ6, PJ7 at $V_{CC} = 2.7$ V (Reference Data)



Figure 5.22 V_{OH}/V_{OL} and I_{OH}/I_{OL} Temperature Characteristics of Ports P40 to P44, P46, Ports PJ6, PJ7 at $V_{CC} = 3.3$ V (Reference Data)

5.3 AC Characteristics

5.3.1 Clock Timing

Table 5.21 Operation Frequency Value (High-Speed Operating Mode)

Conditions: $1.8\text{ V} \leq \text{VCC} = \text{VCC_USB} \leq 3.6\text{ V}$, $1.8\text{ V} \leq \text{AVSS0} \leq 3.6\text{ V}$, $\text{VSS} = \text{AVSS0} = \text{VSS_USB} = 0\text{ V}$, $T_a = -40$ to $+105^\circ\text{C}$

Item		Symbol	VCC				Unit
			1.8 to 2.4 V	2.4 to 2.7 V	2.7 to 3.6 V	When USB in Use*4	
Maximum operating frequency	System clock (ICLK)	f_{max}	8	16	32	24	MHz
	FlashIF clock (FCLK)*1, *2		8	16	32	24	
	Peripheral module clock (PCLKB)		8	16	32	24	
	Peripheral module clock (PCLKD)*3		8	16	32	24	
	USB clock (UCLK)	f_{usb}	—	—	—	48	

Note 1. The lower-limit frequency of FCLK is 1 MHz during programming or erasing of the flash memory. When using FCLK at below 4 MHz, the frequency can be set to 1 MHz, 2 MHz, or 3 MHz. A non-integer frequency such as 1.5 MHz cannot be set.

Note 2. The frequency accuracy of FCLK should be $\pm 3.5\%$. Confirm the frequency accuracy of the clock source.

Note 3. The lower-limit frequency of PCLKD is 4 MHz at 2.4 V or above and 1 MHz at below 2.4 V when the A/D converter is in use.

Note 4. The VCC_USB range is 3.0 to 3.6 V when the USB clock is in use.

Table 5.22 Operation Frequency Value (Middle-Speed Operating Mode)

Conditions: $1.8\text{ V} \leq \text{VCC} = \text{VCC_USB} \leq 3.6\text{ V}$, $1.8\text{ V} \leq \text{AVSS0} \leq 3.6\text{ V}$, $\text{VSS} = \text{AVSS0} = \text{VSS_USB} = 0\text{ V}$, $T_a = -40$ to $+105^\circ\text{C}$

Item		Symbol	VCC				Unit
			1.8 to 2.4 V	2.4 to 2.7 V	2.7 to 3.6 V	When USB in Use*4	
Maximum operating frequency	System clock (ICLK)	f_{max}	8	12	12	12	MHz
	FlashIF clock (FCLK)*1, *2		8	12	12	12	
	Peripheral module clock (PCLKB)		8	12	12	12	
	Peripheral module clock (PCLKD)*3		8	12	12	12	
	USB clock (UCLK)	f_{usb}	—	—	—	48	

Note 1. The lower-limit frequency of FCLK is 1 MHz during programming or erasing of the flash memory. When using FCLK at below 4 MHz, the frequency can be set to 1 MHz, 2 MHz, or 3 MHz. A non-integer frequency such as 1.5 MHz cannot be set.

Note 2. The frequency accuracy of FCLK should be $\pm 3.5\%$.

Note 3. The lower-limit frequency of PCLKD is 4 MHz at 2.4 V or above and 1 MHz at below 2.4 V when the A/D converter is in use.

Note 4. The VCC_USB range is 3.0 to 3.6 V when the USB clock is in use.

Table 5.23 Operation Frequency Value (Low-Speed Operating Mode)

Conditions: $1.8\text{ V} \leq \text{VCC} = \text{VCC_USB} \leq 3.6\text{ V}$, $1.8\text{ V} \leq \text{AVSS0} \leq 3.6\text{ V}$, $\text{VSS} = \text{AVSS0} = \text{VSS_USB} = 0\text{ V}$, $T_a = -40$ to $+105^\circ\text{C}$

Item		Symbol	VCC			Unit
			1.8 to 2.4 V	2.4 to 2.7 V	2.7 to 3.6 V	
Maximum operating frequency	System clock (ICLK)	f_{max}	32.768			kHz
	FlashIF clock (FCLK)*1		32.768			
	Peripheral module clock (PCLKB)		32.768			
	Peripheral module clock (PCLKD)*2		32.768			

Note 1. Programming and erasing the flash memory is impossible.

Note 2. The A/D converter cannot be used.

Table 5.24 Clock TimingConditions: $1.8\text{ V} \leq \text{VCC} = \text{VCC_USB} \leq 3.6\text{ V}$, $1.8\text{ V} \leq \text{AVSS0} \leq 3.6\text{ V}$, $\text{VSS} = \text{AVSS0} = \text{VSS_USB} = 0\text{ V}$, $T_a = -40\text{ to }+105^\circ\text{C}$

Item	Symbol	Min.	Typ.	Max.	Unit	Test Conditions	
XTAL external clock input cycle time	t_{Xcyc}	50	—	—	ns	Figure 5.23	
XTAL external clock input high pulse width	t_{XH}	20	—	—	ns		
XTAL external clock input low pulse width	t_{XL}	20	—	—	ns		
XTAL external clock rising time	t_{Xr}	—	—	5	ns		
XTAL external clock falling time	t_{Xf}	—	—	5	ns		
XTAL external clock input wait time*1	t_{EXWT}	0.5	—	—	μs	Figure 5.25	
Main clock oscillator oscillation frequency	f_{MAIN}	$2.4 \leq \text{VCC} \leq 3.6$	1	—	20		MHz
		$1.8 \leq \text{VCC} < 2.4$	1	—	8		
Main clock oscillation stabilization time (crystal)*2	t_{MAINOSC}	—	3	—	ms	Figure 5.25	
Main clock oscillation stabilization time (ceramic resonator)*2	t_{MAINOSC}	—	50	—	μs		
LOCO clock oscillation frequency	f_{LOCO}	3.44	4.0	4.56	MHz	Figure 5.26	
LOCO clock oscillation stabilization time	t_{LOCO}	—	—	0.5	μs		
IWDT-dedicated clock oscillation frequency	f_{ILOCO}	12.75	15	17.25	kHz	Figure 5.24	
IWDT-dedicated clock oscillation stabilization time	t_{ILOCO}	—	—	50	μs		
HOCO clock oscillation frequency	f_{HOCO}	31.52	32	32.48	MHz	$T_a = -40\text{ to }85^\circ\text{C}$	
		31.68	32	32.32		$T_a = -20\text{ to }85^\circ\text{C}$	
		31.36	32	32.64		$T_a = -40\text{ to }105^\circ\text{C}$	
HOCO clock oscillation stabilization time	t_{HOCO2}	—	—	56	μs	Figure 5.28	
PLL input frequency*3	f_{PLLIN}	4	—	8	MHz	Figure 5.29	
PLL circuit oscillation frequency*3	f_{PLL}	32	—	48	MHz		
PLL clock oscillation stabilization time	t_{PLL}	—	—	50	μs	Figure 5.29	
PLL free-running oscillation frequency	f_{PLLFR}	—	8	—	MHz	Figure 5.30	
Sub-clock oscillator oscillation frequency*5	f_{SUB}	—	32.768	—	kHz		
Sub-clock oscillation stabilization time*4	t_{SUBOSC}	—	0.5	—	s	Figure 5.30	

Note 1. Time until the clock can be used after the main clock oscillator stop bit (MOSCCR.MOSTP) is set to 0 (operating) when the external clock is stable.

Note 2. Reference values when an 8-MHz oscillator is used.

When specifying the main clock oscillator stabilization time, set the MOSCWTCR register with a stabilization time value that is equal to or greater than the oscillator-manufacturer-recommended value.

After changing the setting of the MOSCCR.MOSTP bit so that the main clock oscillator operates, read the OSCOVFSR.MOOVF flag to confirm that it has become 1, and then start using the main clock.

Note 3. The VCC range that the PLL can be used is 2.4 to 3.6 V.

Note 4. After changing the setting of the SOSCCR.SOSTP bit or RCR3.RTCEN bit so that the sub-clock oscillator operates, only start using the sub-clock after the sub-clock oscillation stabilization wait time that is equal to or greater than the oscillator-manufacturer-recommended value has elapsed.

Reference value when a 32.768-kHz resonator is used.

Note 5. Only 32.768 kHz can be used.



Figure 5.23 XTAL External Clock Input Timing



Figure 5.24 IWDT-Dedicated Clock Oscillation Start Timing



Figure 5.25 Main Clock Oscillation Start Timing



Figure 5.26 LOCO Clock Oscillation Start Timing



Figure 5.27 HOCO Clock Oscillation Start Timing (After Reset is Canceled by Setting OFS1.HOCOEN Bit to 0)



Figure 5.28 HOCO Clock Oscillation Start Timing (Oscillation is Started by Setting HOCOEN.HCSTP Bit)



Figure 5.29 PLL Clock Oscillation Start Timing (PLL is Operated after Main Clock Oscillation Has Settled)



Figure 5.30 Sub-Clock Oscillation Start Timing

5.3.2 Reset Timing

Table 5.25 Reset Timing

Conditions: $1.8\text{ V} \leq VCC = VCC_USB \leq 3.6\text{ V}$, $1.8\text{ V} \leq AVSS0 \leq 3.6\text{ V}$, $VSS = AVSS0 = VSS_USB = 0\text{ V}$, $T_a = -40\text{ to }+105^\circ\text{C}$

Item	Symbol	Min.	Typ.	Max.	Unit	Test Conditions	
RES# pulse width	At power-on	t_{RESWP}	3	—	—	ms	Figure 5.31
	Other than above	t_{RESW}	30	—	—	μs	Figure 5.32
Wait time after RES# cancellation (at power-on)	At normal startup*1	t_{RESWT}	—	8.5	—	ms	Figure 5.31
	During fast startup time*2	t_{RESWT}	—	560	—	μs	
Wait time after RES# cancellation (during powered-on state)	t_{RESWT}	—	114	—	μs	Figure 5.32	
Independent watchdog timer reset period	t_{RESWIW}	—	1	—	IWDT clock cycle	Figure 5.33	
Software reset period	t_{RESWSW}	—	1	—	ICLK cycle		
Wait time after independent watchdog timer reset cancellation*3	t_{RESW2}	—	300	—	μs		
Wait time after software reset cancellation	t_{RESW2}	—	168	—	μs		

Note 1. When OFS1.(STUPLVD1REN, FASTSTUP) = 11b.

Note 2. When OFS1.(STUPLVD1REN, FASTSTUP) \neq 11b.

Note 3. When IWDTCR.CKS[3:0] = 0000b.

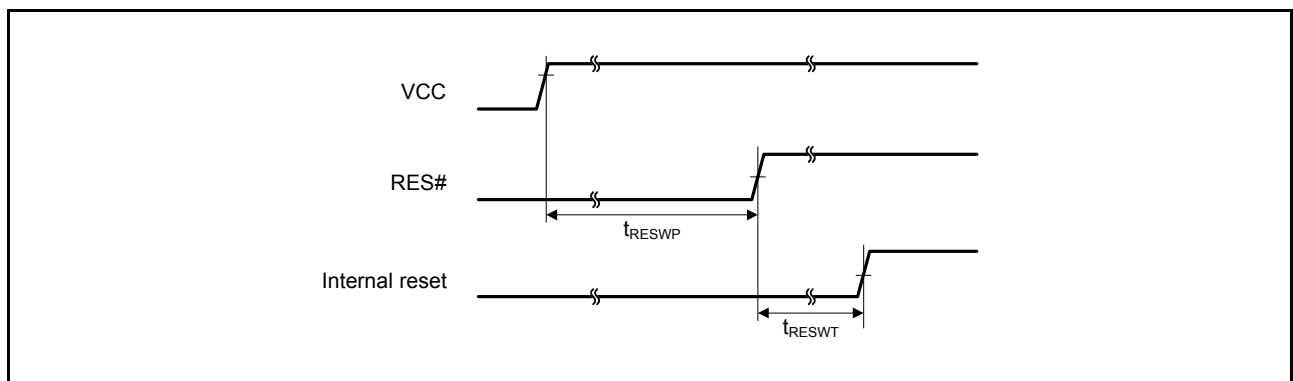

Figure 5.31 Reset Input Timing at Power-On

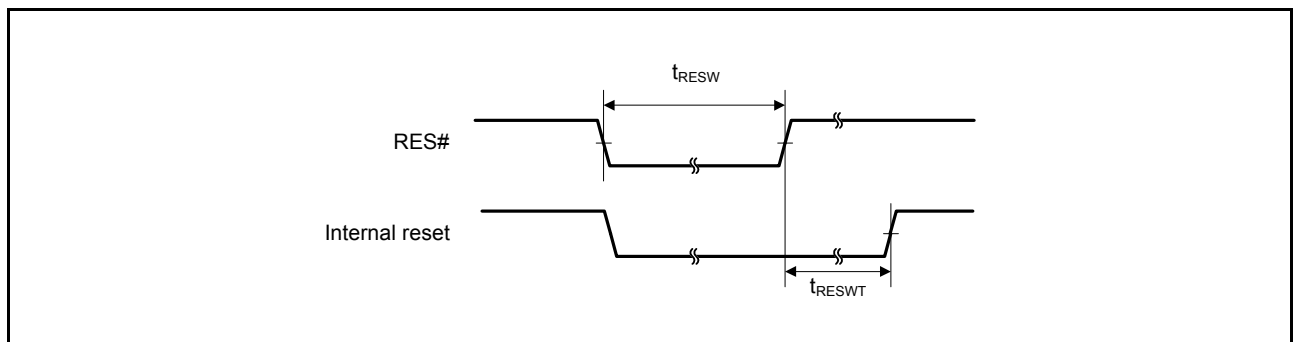

Figure 5.32 Reset Input Timing (1)

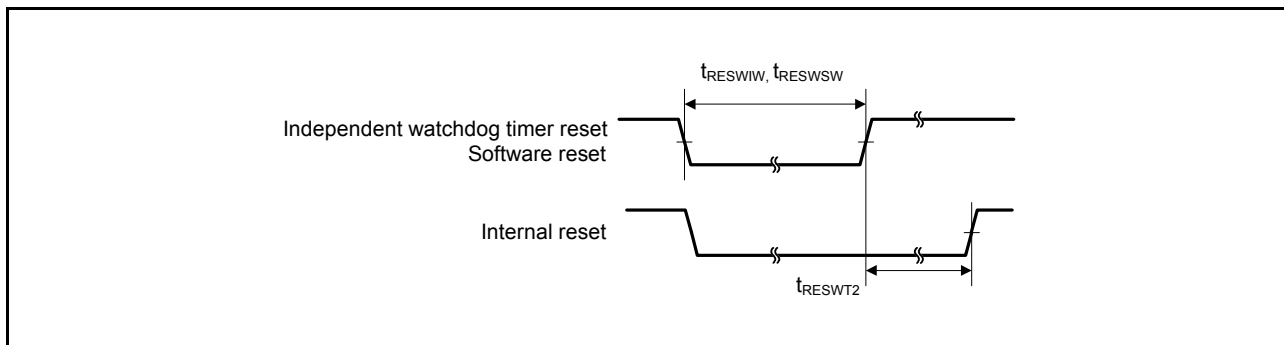

Figure 5.33 Reset Input Timing (2)

5.3.3 Timing of Recovery from Low Power Consumption Modes

Table 5.26 Timing of Recovery from Low Power Consumption Modes (1)

Conditions: $1.8\text{ V} \leq VCC = VCC_USB \leq 3.6\text{ V}$, $1.8\text{ V} \leq AVSS0 \leq 3.6\text{ V}$, $VSS = AVSS0 = VSS_USB = 0\text{ V}$, $T_a = -40\text{ to }+105^\circ\text{C}$

Item		Symbol	Min.	Typ.	Max.	Unit	Test Conditions	
Recovery time from software standby mode*1	High-speed mode Crystal connected to main clock oscillator	Main clock oscillator operating*2	t _{SBYMC}	—	2	3	ms	Figure 5.34
		Main clock oscillator and PLL circuit operating*3	t _{SBYPC}	—	2	3	ms	
	External clock input to main clock oscillator	Main clock oscillator operating*4	t _{SBYEX}	—	35	50	μs	
		Main clock oscillator and PLL circuit operating*5	t _{SBYPE}	—	70	95	μs	
	Sub-clock oscillator operating		t _{SBYSC}	—	650	800	μs	
	HOCO clock oscillator operating*6		t _{SBYHO}	—	40	55	μs	
	LOCO clock oscillator operating		t _{SBYLO}	—	40	55	μs	

Note: When the division ratios of PCLKB, PCLKD, FCLK, and ICLK are all set to 1.

Note 1. The recovery time varies depending on the state of each oscillator when the WAIT instruction is executed. The recovery time when multiple oscillators are operating varies depending on the operating state of the oscillators that are not selected as the system clock source. This applies when only the oscillator listed in each item is operating and the other oscillators are stopped.

Note 2. When the frequency of the crystal is 20 MHz.

When the main clock oscillator wait control register (MOSCWTCR) is set to 04h.

Note 3. When the frequency of PLL is 32 MHz.

When the main clock oscillator wait control register (MOSCWTCR) is set to 04h.

Note 4. When the frequency of the external clock is 20 MHz.

When the main clock oscillator wait control register (MOSCWTCR) is set to 00h.

Note 5. When the frequency of PLL is 32 MHz.

When the main clock oscillator wait control register (MOSCWTCR) is set to 00h.

Note 6. When the frequency of HOCO is 32 MHz.

When the high-speed clock oscillator wait control register (HOCOWTCR) is set to 05h.

Table 5.27 Timing of Recovery from Low Power Consumption Modes (2)Conditions: $1.8\text{ V} \leq VCC = VCC_USB \leq 3.6\text{ V}$, $1.8\text{ V} \leq AVSS0 \leq 3.6\text{ V}$, $VSS = AVSS0 = VSS_USB = 0\text{ V}$, $T_a = -40\text{ to }+105^\circ\text{C}$

Item			Symbol	Min.	Typ.	Max.	Unit	Test Conditions	
Recovery time from software standby mode*1	Middle-speed mode	Crystal connected to main clock oscillator	Main clock oscillator operating*2	t_{SBYMC}	—	2	3	ms	Figure 5.34
			Main clock oscillator and PLL circuit operating*3	t_{SBYPC}	—	2	3	ms	
		External clock input to main clock oscillator	Main clock oscillator operating*4	t_{SBYEX}	—	3	4	μs	
			Main clock oscillator and PLL circuit operating*5	t_{SBYPE}	—	65	85	μs	
		Sub-clock oscillator operating		t_{SBYSC}	—	600	750	μs	
		HOCO clock oscillator operating*6		t_{SBYHO}	—	40	50	μs	
		LOCO clock oscillator operating		t_{SBYLO}	—	4.8	7	μs	

Note: When the division ratios of PCLKB, PCLKD, FCLK, and ICLK are all set to 1.

Note 1. The recovery time varies depending on the state of each oscillator when the WAIT instruction is executed. The recovery time when multiple oscillators are operating varies depending on the operating state of the oscillators that are not selected as the system clock source. This applies when only the oscillator listed in each item is operating and the other oscillators are stopped.

Note 2. When the frequency of the crystal is 12 MHz.

When the main clock oscillator wait control register (MOSCWTCR) is set to 04h.

Note 3. When the frequency of PLL is 12 MHz.

When the main clock oscillator wait control register (MOSCWTCR) is set to 04h.

Note 4. When the frequency of the external clock is 12 MHz.

When the main clock oscillator wait control register (MOSCWTCR) is set to 00h.

Note 5. When the frequency of PLL is 12 MHz.

When the main clock oscillator wait control register (MOSCWTCR) is set to 00h.

Note 6. When the frequency of HOCO is 8 MHz.

When the high-speed clock oscillator wait control register (HOCOWTCR) is set to 05h.

Table 5.28 Timing of Recovery from Low Power Consumption Modes (3)Conditions: $1.8\text{ V} \leq VCC = VCC_USB \leq 3.6\text{ V}$, $1.8\text{ V} \leq AVSS0 \leq 3.6\text{ V}$, $VSS = AVSS0 = VSS_USB = 0\text{ V}$, $T_a = -40\text{ to }+105^\circ\text{C}$

Item			Symbol	Min.	Typ.	Max.	Unit	Test Conditions
Recovery time from software standby mode*1	Low-speed mode	Sub-clock oscillator operating	t_{SBYSC}	—	600	750	μs	Figure 5.34

Note: When the division ratios of PCLKB, PCLKD, FCLK, and ICLK are all set to 1.

Note 1. The sub-clock continues oscillating in software standby mode during low-speed mode.

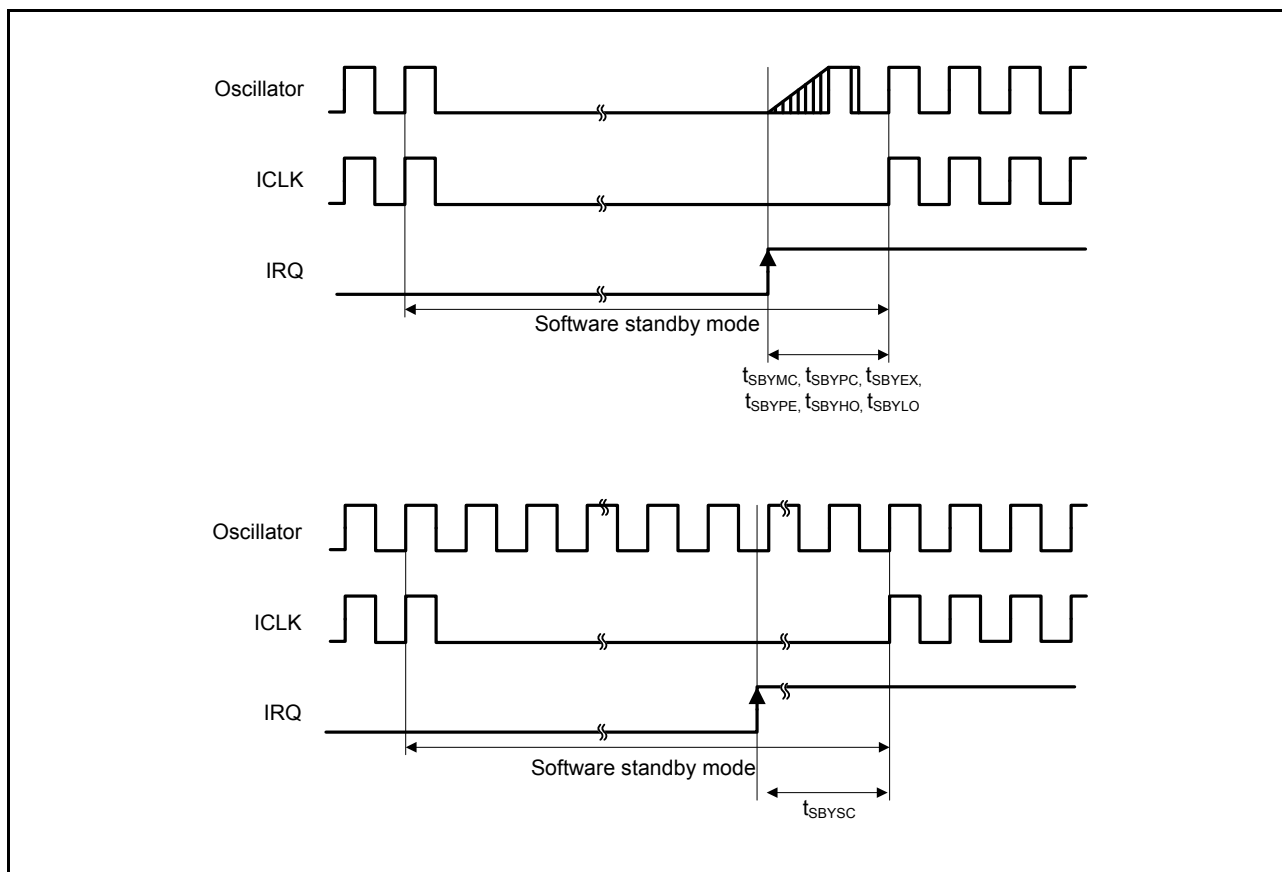

Figure 5.34 Software Standby Mode Cancellation Timing

Table 5.29 Timing of Recovery from Low Power Consumption Modes (4)

Conditions: $1.8\text{ V} \leq VCC = VCC_USB \leq 3.6\text{ V}$, $1.8\text{ V} \leq AVSS0 \leq 3.6\text{ V}$, $VSS = AVSS0 = VSS_USB = 0\text{ V}$, $T_a = -40\text{ to }+105^\circ\text{C}$

Item	Symbol	Min.	Typ.	Max.	Unit	Test Conditions
Recovery time from deep sleep mode*1	High-speed mode*2	—	2	3.5	μs	
	Middle-speed mode*3	—	3	4	μs	
	Low-speed mode*4	—	400	500	μs	

Note: When the division ratios of PCLKB, PCLKD, FCLK, and ICLK are all set to 1.

Note 1. Oscillators continue oscillating in deep sleep mode.

Note 2. When the frequency of the system clock is 32 MHz.

Note 3. When the frequency of the system clock is 12 MHz.

Note 4. When the frequency of the system clock is 32.768 kHz.

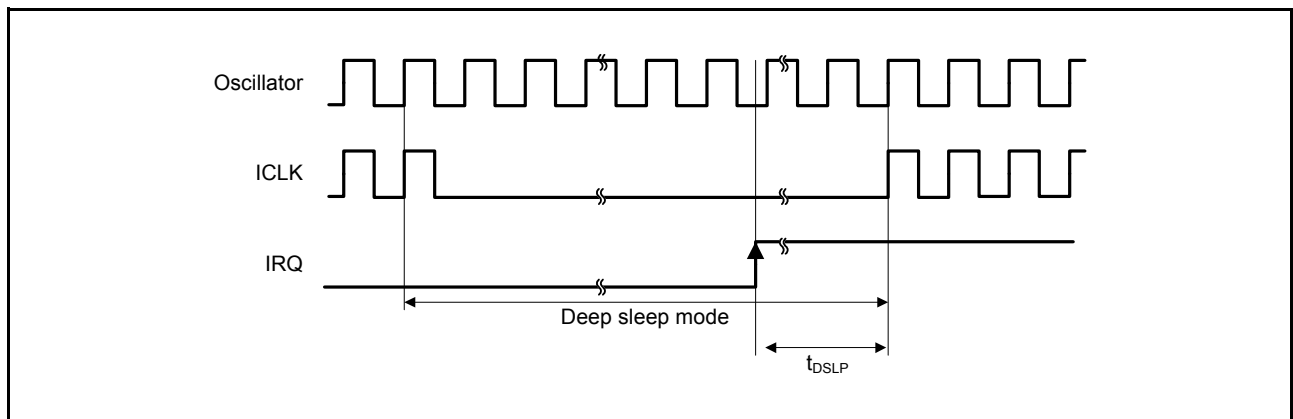

Figure 5.35 Deep Sleep Mode Cancellation Timing

Table 5.30 Timing of Recovery from Low Power Consumption Modes (5) Operating Mode Transition Time

Conditions: $1.8\text{ V} \leq VCC = VCC_USB \leq 3.6\text{ V}$, $1.8\text{ V} \leq AVSS0 \leq 3.6\text{ V}$, $VSS = AVSS0 = VSS_USB = 0\text{ V}$, $T_a = -40\text{ to }+105^\circ\text{C}$

Mode before Transition	Mode after Transition	ICLK Frequency	Transition Time			Unit
			Min.	Typ.	Max.	
High-speed operating mode	Middle-speed operating mode	8 MHz	—	10	—	μs
Middle-speed operating mode	High-speed operating mode	8 MHz	—	37.5	—	μs
Low-speed operating mode	Middle-speed operating mode, high-speed operating mode	32.768 kHz	—	213.62	—	μs
Middle-speed operating mode, high-speed operating mode	Low-speed operating mode	32.768 kHz	—	183.11	—	μs

Note: When the division ratios of PCLKB, PCLKD, FCLK, and ICLK are all set to 1.

5.3.4 Control Signal Timing

Table 5.31 Control Signal Timing

Conditions: $1.8\text{ V} \leq VCC = VCC_USB \leq 3.6\text{ V}$, $1.8\text{ V} \leq AVSS0 \leq 3.6\text{ V}$, $VSS = AVSS0 = VSS_USB = 0\text{ V}$, $T_a = -40\text{ to }+105^\circ\text{C}$

Item	Symbol	Min.	Typ.	Max.	Unit	Test Conditions	
NMI pulse width	t_{NMIW}	200	—	—	ns	NMI digital filter disabled (NMIFLTE.NFLTEN = 0)	$t_{Pcyc} \times 2 \leq 200\text{ ns}$
		$t_{Pcyc} \times 2^{*1}$	—	—			$t_{Pcyc} \times 2 > 200\text{ ns}$
		200	—	—		NMI digital filter enabled (NMIFLTE.NFLTEN = 1)	$t_{NMICK} \times 3 \leq 200\text{ ns}$
		$t_{NMICK} \times 3.5^{*2}$	—	—			$t_{NMICK} \times 3 > 200\text{ ns}$
IRQ pulse width	t_{IRQW}	200	—	—	ns	IRQ digital filter disabled (IRQFLTE0.FLTENi = 0)	$t_{Pcyc} \times 2 \leq 200\text{ ns}$
		$t_{Pcyc} \times 2^{*1}$	—	—			$t_{Pcyc} \times 2 > 200\text{ ns}$
		200	—	—		IRQ digital filter enabled (IRQFLTE0.FLTENi = 1)	$t_{IRQCK} \times 3 \leq 200\text{ ns}$
		$t_{IRQCK} \times 3.5^{*3}$	—	—			$t_{IRQCK} \times 3 > 200\text{ ns}$

Note: • 200 ns minimum in software standby mode.

Note 1. t_{Pcyc} indicates the cycle of PCLKB.

Note 2. t_{NMICK} indicates the cycle of the NMI digital filter sampling clock.

Note 3. t_{IRQCK} indicates the cycle of the IRQi digital filter sampling clock (i = 0 to 7).



Figure 5.36 NMI Interrupt Input Timing



Figure 5.37 IRQ Interrupt Input Timing

5.3.5 Timing of On-Chip Peripheral Modules

Table 5.32 Timing of On-Chip Peripheral Modules (1)Conditions: $1.8\text{ V} \leq V_{CC} = V_{CC_USB} \leq 3.6\text{ V}$, $1.8\text{ V} \leq AV_{SS0} \leq 3.6\text{ V}$, $V_{SS} = AV_{SS0} = V_{SS_USB} = 0\text{ V}$, $T_a = -40$ to $+105^\circ\text{C}$

Item		Symbol	Min.	Max.	Unit*1	Test Conditions	
I/O ports	Input data pulse width	t_{PRW}	1.5	—	t_{Pcyc}	Figure 5.38	
MTU2	Input capture input pulse width	Single-edge setting	t_{TICW}	1.5	—	t_{Pcyc}	Figure 5.39
		Both-edge setting		2.5			
	Timer clock pulse width	Single-edge setting	t_{TCKWH} , t_{TCKWL}	1.5	—	t_{Pcyc}	Figure 5.40
		Both-edge setting		2.5			
Phase counting mode		2.5					
POE	POE# input pulse width	t_{POEW}	1.5	—	t_{Pcyc}	Figure 5.41	
SCI	Input clock cycle	Asynchronous	t_{Scyc}	4	—	t_{Pcyc}	Figure 5.42
		Clock synchronous		6			
	Input clock pulse width		t_{SCKW}	0.4	0.6	t_{Scyc}	
	Input clock rise time		t_{SCKr}	—	20	ns	
	Input clock fall time		t_{SCKf}	—	20	ns	
	Output clock cycle	Asynchronous	t_{Scyc}	16	—	t_{Pcyc}	Figure 5.43 C = 30 pF
		Clock synchronous		4	—		
	Output clock pulse width		t_{SCKW}	0.4	0.6	t_{Scyc}	
	Output clock rise time		t_{SCKr}	—	20	ns	
	Output clock fall time		t_{SCKf}	—	20	ns	
	Transmit data delay time (master)	Clock synchronous		t_{TXD}	—	40	ns
	Transmit data delay time (slave)	Clock synchronous	2.7 V or above	—	65	ns	
			1.8 V or above	—	100	ns	
	Receive data setup time (master)	Clock synchronous	2.7 V or above	t_{RXS}	65	—	ns
1.8 V or above				90	—	ns	
Receive data setup time (slave)	Clock synchronous			40	—	ns	
Receive data hold time	Clock synchronous		t_{RXH}	40	—	ns	
A/D converter	Trigger input pulse width	t_{TRGW}	1.5	—	t_{Pcyc}	Figure 5.44	
CAC	CACREF input pulse width	$t_{Pcyc} \leq t_{cac}^{*2}$	t_{CACREF}	$4.5 t_{cac} + 3 t_{Pcyc}$	—	ns	
		$t_{Pcyc} > t_{cac}^{*2}$		$5 t_{cac} + 6.5 t_{Pcyc}$			
CLKOUT	CLKOUT pin output cycle*4	VCC = 2.7 V or above	t_{Cyc}	125	—	ns	
		VCC = 1.8 V or above		250			
	CLKOUT pin high pulse width*3	VCC = 2.7 V or above	t_{CH}	35	—	ns	
		VCC = 1.8 V or above		70			
	CLKOUT pin low pulse width*3	VCC = 2.7 V or above	t_{CL}	35	—	ns	
		VCC = 1.8 V or above		70			
	CLKOUT pin output rise time	VCC = 2.7 V or above	t_{Cr}	—	15	ns	
		VCC = 1.8 V or above		30			
CLKOUT pin output fall time	VCC = 2.7 V or above	t_{Cf}	—	15	ns		
	VCC = 1.8 V or above		30				

Note 1. t_{Pcyc} : PCLK cycleNote 2. t_{cac} : CAC count clock source cycle

Note 3. When the LOCO is selected as the clock output source (CKOCR.CKOSSEL[2:0] bits = 000b), set the clock output division ratio selection to divided by 2 (CKOCR.CKODIV[2:0] bits = 001b).

Note 4. When the XTAL external clock input or an oscillator is used with divided by 1 (CKOCR.CKOSSEL[2:0] bits = 010b and CKOCR.CKODIV[2:0] bits = 000b) to output from CLKOUT, the above should be satisfied with an input duty cycle of 45 to 55%.

Table 5.33 Timing of On-Chip Peripheral Modules (2)

Conditions: $1.8\text{ V} \leq V_{CC} = V_{CC_USB} \leq 3.6\text{ V}$, $1.8\text{ V} \leq AV_{SS0} \leq 3.6\text{ V}$, $V_{SS} = AV_{SS0} = V_{SS_USB} = 0\text{ V}$,
 $T_a = -40\text{ to }+105^\circ\text{C}$, $C = 30\text{ pF}$

Item			Symbol	Min.	Max.	Unit	Test Conditions
RSPI	RSPCK clock cycle	Master	t_{SPCyc}	2	4096	t_{Pcyc}^{*1}	Figure 5.46
		Slave		8	4096		
	RSPCK clock high pulse width	Master	t_{SPCKWH}	$(t_{SPCyc} - t_{SPCKr} - t_{SPCKf})/2 - 3$	—	ns	
		Slave		$(t_{SPCyc} - t_{SPCKr} - t_{SPCKf})/2$	—		
	RSPCK clock low pulse width	Master	t_{SPCKWL}	$(t_{SPCyc} - t_{SPCKr} - t_{SPCKf})/2 - 3$	—	ns	
		Slave		$(t_{SPCyc} - t_{SPCKr} - t_{SPCKf})/2$	—		
	RSPCK clock rise/fall time	Output	t_{SPCKr} , t_{SPCKf}	2.7 V or above	10	ns	
				1.8 V or above	15		
		Input	—	1	μs		
	Data input setup time	Master	t_{SU}	2.7 V or above	—	ns	Figure 5.47 to Figure 5.52
				1.8 V or above	30		
		Slave		$25 - t_{Pcyc}$	—		
	Data input hold time	Master	t_H	RSPCK set to a division ratio other than PCLKB divided by 2	t_{Pcyc}	ns	
				RSPCK set to PCLKB divided by 2	0		
		Slave	t_H	$20 + 2 \times t_{Pcyc}$	—		
	SSL setup time	Master	t_{LEAD}	$-30 + N \times 2 \times t_{SPCyc}$	—	ns	
		Slave		2	—		
	SSL hold time	Master	t_{LAG}	$-30 + N \times 3 \times t_{SPCyc}$	—	ns	
		Slave		2	—		
	Data output delay time	Master	t_{OD}	2.7 V or above	14	ns	
				1.8 V or above	30		
		Slave		2.7 V or above	$3 \times t_{Pcyc} + 65$		
				1.8 V or above	$3 \times t_{Pcyc} + 105$		
	Data output hold time	Master	t_{OH}	2.7 V or above	0	ns	
				1.8 V or above	-20		
		Slave		0	—		
	Successive transmission delay time	Master	t_{TD}	$t_{SPCyc} + 2 \times t_{Pcyc}$	$8 \times t_{SPCyc} + 2 \times t_{Pcyc}$	ns	
		Slave		$4 \times t_{Pcyc}$	—		
	MOSI and MISO rise/fall time	Output	t_{Dr} , t_{Df}	2.7 V or above	10	ns	
				1.8 V or above	20		
		Input		—	1	μs	
	SSL rise/fall time	Output	t_{SSLr} , t_{SSLf}	—	20	ns	
		Input		—	1		
	Slave access time	2.7 V or above	t_{SA}	—	6	t_{Pcyc}	Figure 5.51, Figure 5.52
		1.8 V or above		—	7		
	Slave output release time	2.7 V or above	t_{REL}	—	5	t_{Pcyc}	
		1.8 V or above		—	6		

Note 1. t_{Pcyc} : PCLK cycle

Note 2. N: An integer from 1 to 8 that can be set by the RSPI clock delay register (SPCKD)

Note 3. N: An integer from 1 to 8 that can be set by the RSPI slave select negation delay register (SSLND)

Table 5.34 Timing of On-Chip Peripheral Modules (3)

Conditions: $1.8\text{ V} \leq VCC = VCC_USB \leq 3.6\text{ V}$, $1.8\text{ V} \leq AVSS0 \leq 3.6\text{ V}$, $VSS = AVSS0 = VSS_USB = 0\text{ V}$,
 $T_a = -40\text{ to }+105^\circ\text{C}$, $C = 30\text{ pF}$

Item		Symbol	Min.	Max.	Unit*1	Test Conditions	
Simple SPI	SCK clock cycle output (master)	t_{SPCyc}	4	65536	t_{Pcyc}	Figure 5.46	
	SCK clock cycle input (slave)		6	65536			
	SCK clock high pulse width		t_{SPCKWH}	0.4	0.6		t_{SPCyc}
	SCK clock low pulse width		t_{SPCKWL}	0.4	0.6		t_{SPCyc}
	SCK clock rise/fall time		t_{SPCKr}, t_{SPCKf}	—	20		ns
	Data input setup time (master)	2.7 V or above	t_{SU}	65	—	ns	Figure 5.47, Figure 5.49
		1.8 V or above		95	—		
	Data input setup time (slave)			40	—		
	Data input hold time		t_H	40	—	ns	
	SS input setup time		t_{LEAD}	3	—	t_{Pcyc}	
	SS input hold time		t_{LAG}	3	—	t_{Pcyc}	
	Data output delay time (master)		t_{OD}	—	40	ns	
	Data output delay time (slave)	2.7 V or above		—	65		
		1.8 V or above		—	85		
	Data output hold time (master)	2.7 V or above	t_{OH}	-10	—	ns	
1.8 V or above		-20		—			
Data output hold time (slave)		-10		—			
Data rise/fall time		t_{Dr}, t_{Df}	—	20	ns		
SS input rise/fall time		t_{SSLr}, t_{SSLf}	—	20	ns		
Slave access time		t_{SA}	—	6	t_{Pcyc}	Figure 5.51, Figure 5.52	
Slave output release time		t_{REL}	—	6	t_{Pcyc}		

Note 1. t_{Pcyc} : PCLK cycle

Table 5.35 Timing of On-Chip Peripheral Modules (4)

Conditions: $2.7\text{ V} \leq V_{CC} = V_{CC_USB} \leq 3.6\text{ V}$, $2.7\text{ V} \leq AV_{SS0} \leq 3.6\text{ V}$, $V_{SS} = AV_{SS0} = V_{SS_USB} = 0\text{ V}$, $f_{PCLKB} \leq 32\text{ MHz}$,
 $T_a = -40\text{ to }+105^\circ\text{C}$

Item		Symbol	Min.*1	Max.	Unit	Test Conditions
RIIC (Standard mode, SMBus)	SCL0 input cycle time	t_{SCL}	$6(12) \times t_{IICcyc} + 1300$	—	ns	Figure 5.53
	SCL0 input high pulse width	t_{SCLH}	$3(6) \times t_{IICcyc} + 300$	—	ns	
	SCL0 input low pulse width	t_{SCLL}	$3(6) \times t_{IICcyc} + 300$	—	ns	
	SCL0, SDA0 input rise time	t_{Sr}	—	1000	ns	
	SCL0, SDA0 input fall time	t_{Sf}	—	300	ns	
	SCL0, SDA0 input spike pulse removal time	t_{SP}	0	$1(4) \times t_{IICcyc}$	ns	
	SDA0 input bus free time	t_{BUF}	$3(6) \times t_{IICcyc} + 300$	—	ns	
	START condition input hold time	t_{STAH}	$t_{IICcyc} + 300$	—	ns	
	Repeated START condition input setup time	t_{STAS}	1000	—	ns	
	STOP condition input setup time	t_{STOS}	1000	—	ns	
	Data input setup time	t_{SDAS}	$t_{IICcyc} + 50$	—	ns	
	Data input hold time	t_{SDAH}	0	—	ns	
	SCL0, SDA0 capacitive load	C_b	—	400	pF	
RIIC (Fast mode)	SCL0 input cycle time	t_{SCL}	$6(12) \times t_{IICcyc} + 600$	—	ns	Figure 5.53
	SCL0 input high pulse width	t_{SCLH}	$3(6) \times t_{IICcyc} + 300$	—	ns	
	SCL0 input low pulse width	t_{SCLL}	$3(6) \times t_{IICcyc} + 300$	—	ns	
	SCL0, SDA0 input rise time	t_{Sr}	—*2	300	ns	
	SCL0, SDA0 input fall time	t_{Sf}	—*2	300	ns	
	SCL0, SDA0 input spike pulse removal time	t_{SP}	0	$1(4) \times t_{IICcyc}$	ns	
	SDA0 input bus free time	t_{BUF}	$3(6) \times t_{IICcyc} + 300$	—	ns	
	START condition input hold time	t_{STAH}	$t_{IICcyc} + 300$	—	ns	
	Repeated START condition input setup time	t_{STAS}	300	—	ns	
	STOP condition input setup time	t_{STOS}	300	—	ns	
	Data input setup time	t_{SDAS}	$t_{IICcyc} + 50$	—	ns	
	Data input hold time	t_{SDAH}	0	—	ns	
	SCL0, SDA0 capacitive load	C_b	—	400	pF	

Note: • t_{IICcyc} : RIIC internal reference count clock (IIC ϕ) cycle

Note 1. The value in parentheses is used when the ICMR3.NF[1:0] bits are set to 11b while a digital filter is enabled with the ICFER.NFE bit = 1.

Note 2. The minimum t_{sr} and t_{sf} specifications for fast mode are not set.

Table 5.36 Timing of On-Chip Peripheral Modules (5)

Conditions: $2.7\text{ V} \leq VCC = VCC_USB \leq 3.6\text{ V}$, $2.7\text{ V} \leq AVSS0 \leq 3.6\text{ V}$, $VSS = AVSS0 = VSS_USB = 0\text{ V}$, $fPCLKB \leq 32\text{ MHz}$, $T_a = -40\text{ to }+105^\circ\text{C}$

Item		Symbol	Min.	Max.	Unit	Test Conditions
Simple I ² C (Standard mode)	SDA0 input rise time	t_{Sr}	—	1000	ns	Figure 5.53
	SDA0 input fall time	t_{Sf}	—	300	ns	
	SDA0 input spike pulse removal time	t_{SP}	0	$4 \times t_{pcyc}^{*1}$	ns	
	Data input setup time	t_{SDAS}	250	—	ns	
	Data input hold time	t_{SDAH}	0	—	ns	
	SCL0, SDA0 capacitive load	C_b	—	400	pF	
Simple I ² C (Fast mode)	SCL0, SDA0 input rise time	t_{Sr}	—	300	ns	Figure 5.53
	SCL0, SDA0 input fall time	t_{Sf}	—	300	ns	
	SCL0, SDA0 input spike pulse removal time	t_{SP}	0	$4 \times t_{pcyc}^{*1}$	ns	
	Data input setup time	t_{SDAS}	100	—	ns	
	Data input hold time	t_{SDAH}	0	—	ns	
	SCL0, SDA0 capacitive load	C_b	—	400	pF	

Note: • t_{pcyc} : PCLK cycle

Note 1. This applies when the SMR.CKS[1:0] bits = 00b and the SNFR.NFCS[2:0] bits = 010b while the SNFR.NFE bit = 1 and the digital filter is enabled.

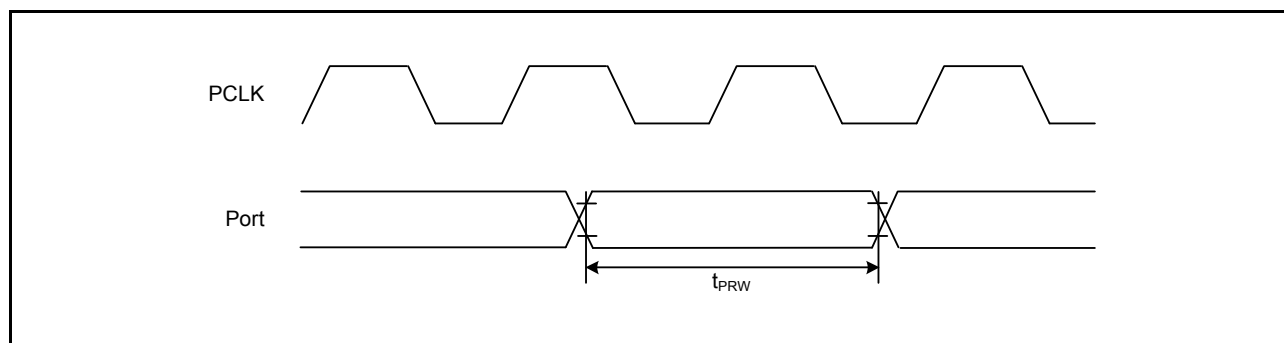

Figure 5.38 I/O Port Input Timing

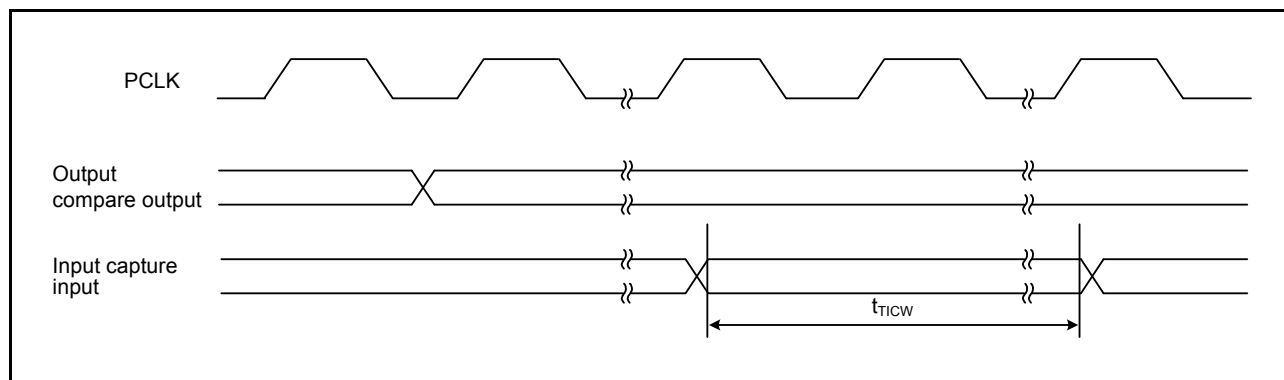

Figure 5.39 MTU2 Input/Output Timing



Figure 5.40 MTU2 Clock Input Timing



Figure 5.41 POE# Input Timing



Figure 5.42 SCK Clock Input Timing



Figure 5.43 SCI Input/Output Timing: Clock Synchronous Mode

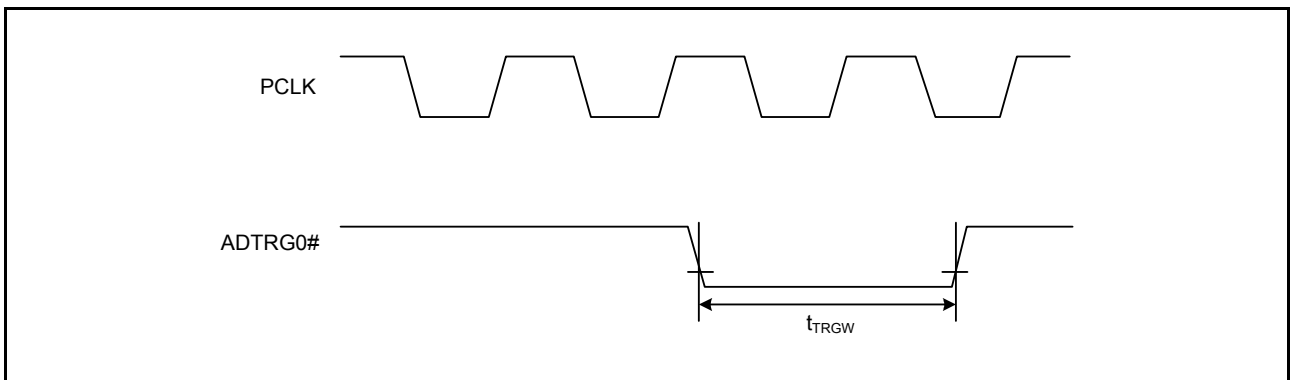

Figure 5.44 A/D Converter External Trigger Input Timing



Figure 5.45 CLKOUT Output Timing

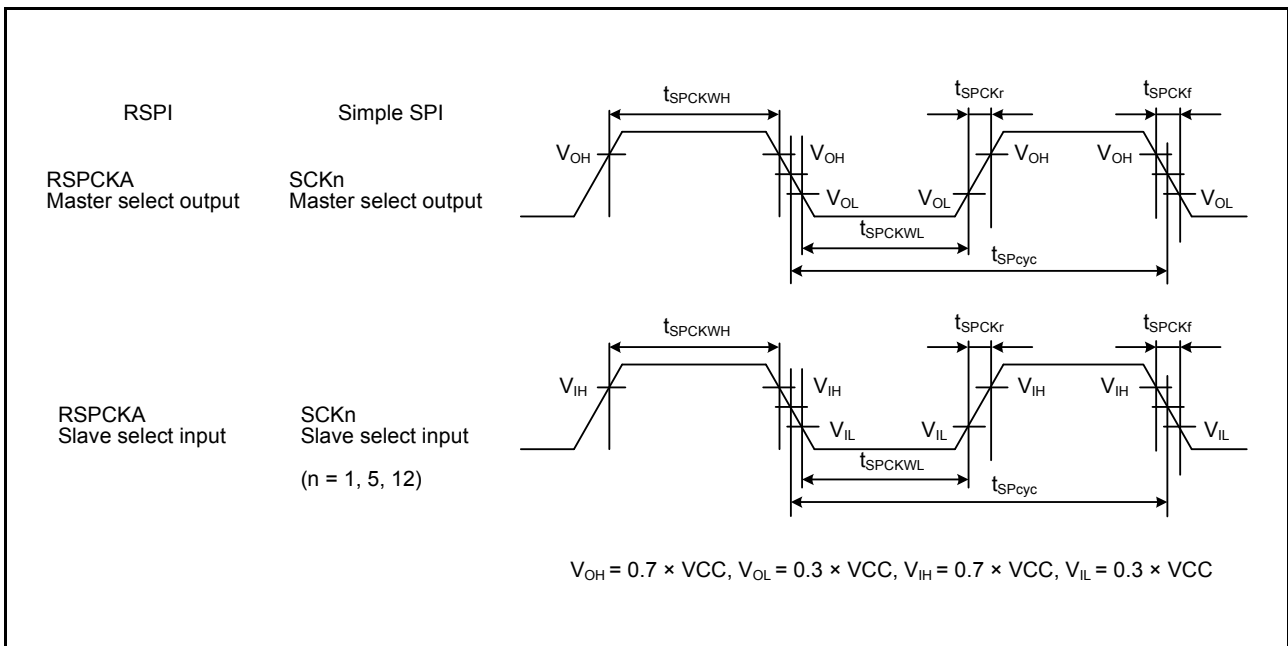

Figure 5.46 RSPI Clock Timing and Simple SPI Clock Timing

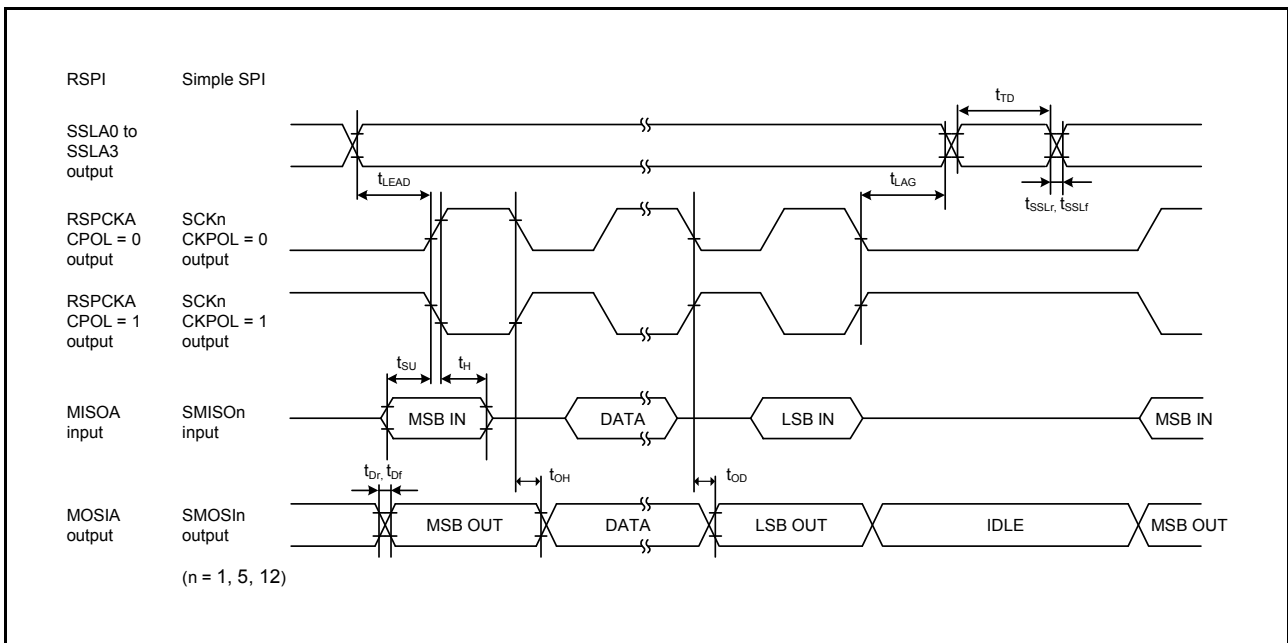

Figure 5.47 RSPI Timing (Master, CPHA = 0) (Bit Rate: PCLKB Set to Division Ratio Other Than Divided by 2) and Simple SPI Timing (Master, CKPH = 1)



Figure 5.48 RSPI Timing (Master, CPHA = 0) (Bit Rate: PCLKB Set to Divided by 2)



Figure 5.49 RSPI Timing (Master, CPHA = 1) (Bit Rate: PCLKB Set to Division Ratio Other Than Divided by 2) and Simple SPI Timing (Master, CKPH = 0)



Figure 5.50 RSPI Timing (Master, CPHA = 1) (Bit Rate: PCLKB Set to Divided by 2)



Figure 5.51 RSPI Timing (Slave, CPHA = 0) and Simple SPI Timing (Slave, CKPH = 1)

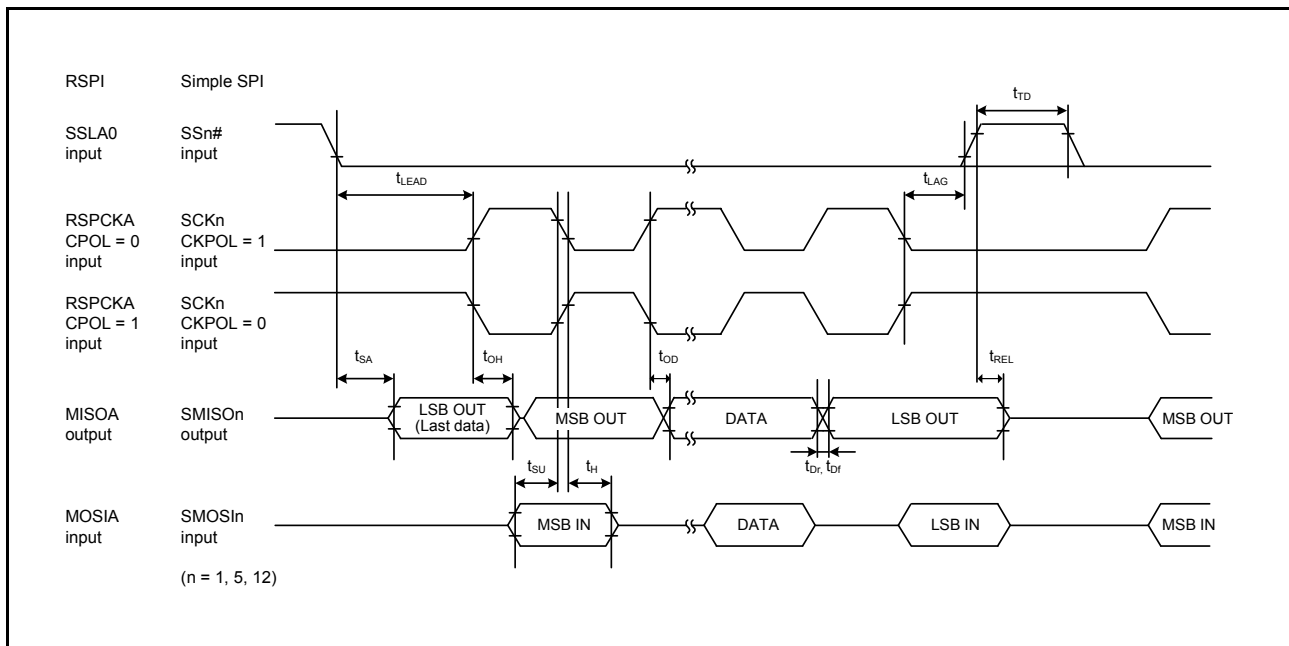

Figure 5.52 RSPI Timing (Slave, CPHA = 1) and Simple SPI Timing (Slave, CKPH = 0)

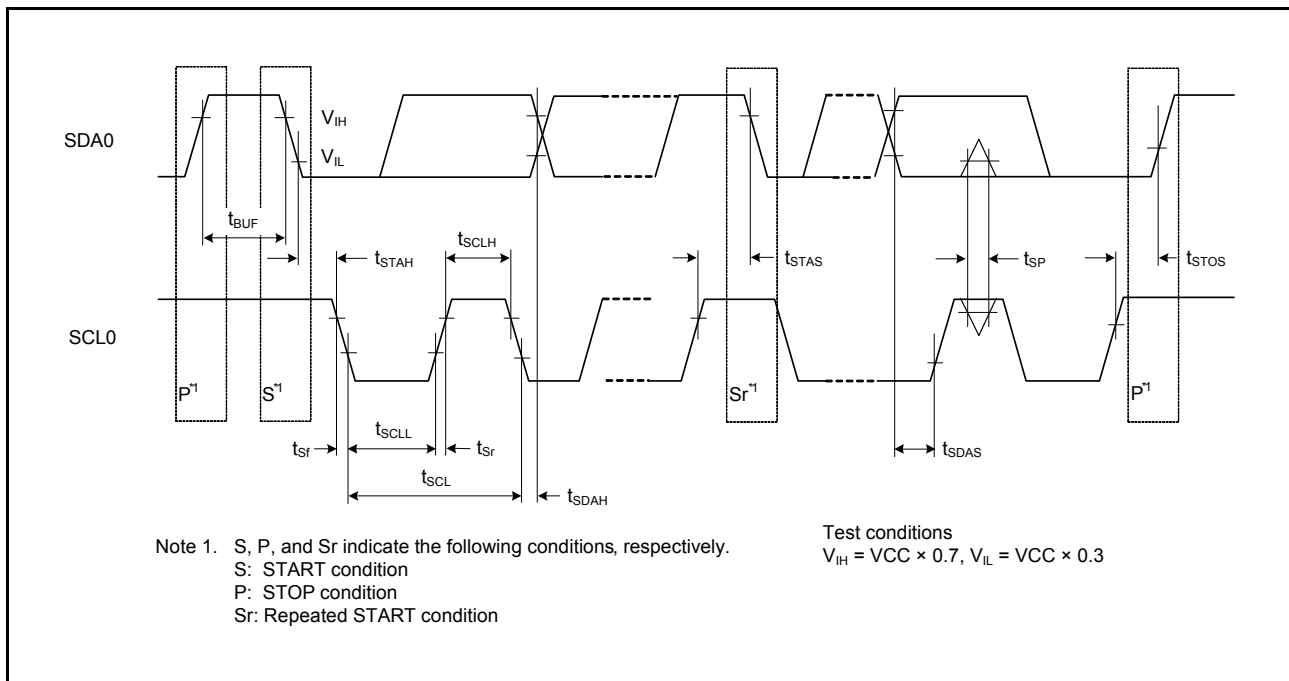

Figure 5.53 I2C Bus Interface Input/Output Timing and Simple I2C Bus Interface Input/Output Timing

5.4 USB Characteristics

Table 5.37 USB Characteristics (USB0_DP and USB0_DM Pin Characteristics)

Conditions: $3.0\text{ V} \leq VCC = VCC_USB \leq 3.6\text{ V}$, $3.0\text{ V} \leq AVSS0 \leq 3.6\text{ V}$, $VSS = AVSS0 = VSS_USB = 0\text{ V}$, $T_a = -40\text{ to }+105^\circ\text{C}$

Item		Symbol	Min.	Max.	Unit	Test Conditions	
Input characteristics	Input high level voltage	V_{IH}	2.0	—	V		
	Input low level voltage	V_{IL}	—	0.8	V		
	Differential input sensitivity	V_{DI}	0.2	—	V	USB0_DP – USB0_DM	
	Differential common mode range	V_{CM}	0.8	2.5	V		
Output characteristics	Output high level voltage	V_{OH}	2.8	VCC_USB	V	$I_{OH} = -200\ \mu\text{A}$	
	Output low level voltage	V_{OL}	0.0	0.3	V	$I_{OL} = 2\ \text{mA}$	
	Cross-over voltage		V_{CRS}	1.3	2.0	V	Figure 5.54 Figure 5.55
	Rise time	FS	t_r	4	20	ns	
		LS		75	300		
	Fall time	FS	t_f	4	20	ns	
		LS		75	300		
	Rise/fall time ratio	FS	t_r/t_f	90	111.11	%	
		LS		80	125		
	Output resistance		Z_{DRV}	28	44	Ω	(Adjusting the resistance of external elements is not necessary.)
VBUS characteristics	VBUS input voltage	V_{IH}	$VCC \times 0.8$	—	V		
		V_{IL}	—	$VCC \times 0.2$	V		
	VBUS (P16) input leakage current	$ I_{VBUSIN} $	—	10	μA	USB0_VBUS = 5.5V	
Pull-up, pull-down	Pull-down resistor	R_{PD}	14.25	24.80	k Ω		
	Pull-up resistor	R_{PUI}	0.9	1.575	k Ω	During idle state	
		R_{PUA}	1.425	3.09	k Ω	During reception	
Battery Charging Specification Ver 1.2	USB0_DP sink current	I_{DP_SINK}	25	175	μA		
	USB0_DM sink current	I_{DM_SINK}	25	175	μA		
	DCD source current	I_{DP_SRC}	7	13	μA		
	Data detection voltage	V_{DAT_REF}	0.25	0.4	V		
	USB0_DP source current	V_{DP_SRC}	0.5	0.7	V	Output current = 250 μA	
	USB0_DM source current	V_{DM_SRC}	0.5	0.7	V	Output current = 250 μA	

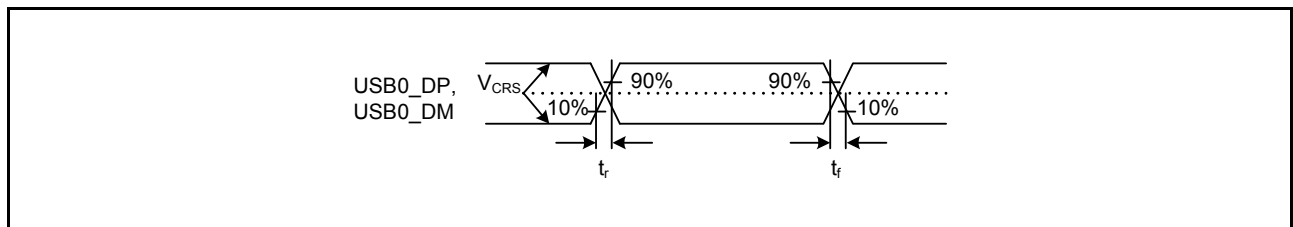

Figure 5.54 USB0_DP and USB0_DM Output Timing



Figure 5.55 Test Circuit

5.5 A/D Conversion Characteristics

Table 5.38 A/D Conversion Characteristics (1)

Conditions: $2.7\text{ V} \leq V_{CC} = V_{CC_USB} \leq 3.6\text{ V}$, $2.7\text{ V} \leq AV_{CC0} \leq 3.6\text{ V}$, $2.7\text{ V} \leq V_{REFH0} \leq AV_{CC0}$,
 $V_{SS} = AV_{SS0} = V_{REFL0} = V_{SS_USB} = 0\text{ V}$, $T_a = -40\text{ to }+105^\circ\text{C}$

Item		Min.	Typ.	Max.	Unit	Test Conditions
Frequency		4	—	32	MHz	
Resolution		—	—	12	Bit	
Conversion time*1 (Operation at PCLKD = 32 MHz)	Permissible signal source impedance (Max.) = 0.3 k Ω	1.031 (0.313)*2	—	—	μs	High-precision channel ADCSR.ADHSC bit = 1 ADSSTRn.SST[7:0] bits = 09h
		1.375 (0.641)*2	—	—		Normal-precision channel ADCSR.ADHSC bit = 1 ADSSTRn.SST[7:0] bits = 14h
Analog input effective range		0	—	VREFH0	V	
Offset error		—	± 0.5	± 4.5	LSB	High-precision channel PJ6PFS.ASEL bit = 1 PJ7PFS.ASEL bit = 1
				± 6.0	LSB	Other than above
Full-scale error		—	± 0.75	± 4.5	LSB	High-precision channel PJ6PFS.ASEL bit = 1 PJ7PFS.ASEL bit = 1
				± 6.0	LSB	Other than above
Quantization error		—	± 0.5	—	LSB	
Absolute accuracy		—	± 1.25	± 5.0	LSB	High-precision channel PJ6PFS.ASEL bit = 1 PJ7PFS.ASEL bit = 1
				± 8.0	LSB	Other than above
DNL differential nonlinearity error		—	± 1.0	—	LSB	
INL integral nonlinearity error		—	± 1.0	± 3.0	LSB	

Note: • The characteristics apply when no pin functions other than A/D converter input are used. Absolute accuracy includes quantization errors. Offset error, full-scale error, DNL differential nonlinearity error, and INL integral nonlinearity error do not include quantization errors.

Note 1. The conversion time is the sum of the sampling time and the comparison time. As the test conditions, the number of sampling states is indicated.

Note 2. The value in parentheses indicates the sampling time.



Figure 5.56 AVCC0 to AVREFH0 Voltage Range

Table 5.39 A/D Conversion Characteristics (2)

Conditions: $2.4\text{ V} \leq V_{CC} = V_{CC_USB} \leq 3.6\text{ V}$, $2.4\text{ V} \leq AV_{CC0} \leq 3.6\text{ V}$, $2.4\text{ V} \leq V_{REFH0} \leq AV_{CC0}$, $V_{SS} = AV_{SS0} = V_{REFL0} = V_{SS_USB} = 0\text{ V}$, $T_a = -40$ to $+105^\circ\text{C}$

Item		Min.	Typ.	Max.	Unit	Test Conditions
Frequency		4	—	16	MHz	
Resolution		—	—	12	Bit	
Conversion time*1 (Operation at PCLKD = 16 MHz)	Permissible signal source impedance (Max.) = 1.0 k Ω	2.062 (0.625)*2	—	—	μs	High-precision channel ADCSR.ADHSC bit = 1 ADSSTRn.SST[7:0] bits = 09h
		2.750 (1.313)*2	—	—	μs	Normal-precision channel ADCSR.ADHSC bit = 1 ADSSTRn.SST[7:0] bits = 14h
Analog input effective range		0	—	VREFH0	V	
Offset error		—	± 0.5	± 6.0	LSB	
Full-scale error		—	± 1.25	± 6.0	LSB	
Quantization error		—	± 0.5	—	LSB	
Absolute accuracy		—	± 3.0	± 8.0	LSB	
DNL differential nonlinearity error		—	± 1.0	—	LSB	
INL integral nonlinearity error		—	± 1.5	± 3.0	LSB	

Note: • The characteristics apply when no pin functions other than A/D converter input are used. Absolute accuracy includes quantization errors. Offset error, full-scale error, DNL differential nonlinearity error, and INL integral nonlinearity error do not include quantization errors.

Note 1. The conversion time is the sum of the sampling time and the comparison time. As the test conditions, the number of sampling states is indicated.

Note 2. The value in parentheses indicates the sampling time.

Table 5.40 A/D Conversion Characteristics (3)

Conditions: $1.8\text{ V} \leq V_{CC} = V_{CC_USB} \leq 3.6\text{ V}$, $1.8\text{ V} \leq AV_{CC0} \leq 3.6\text{ V}$, $1.8\text{ V} \leq V_{REFH0} \leq AV_{CC0}$, $V_{SS} = AV_{SS0} = V_{REFL0} = V_{SS_USB} = 0\text{ V}$, $T_a = -40$ to $+105^\circ\text{C}$

Item		Min.	Typ.	Max.	Unit	Test Conditions
Frequency		1	—	8	MHz	
Resolution		—	—	12	Bit	
Conversion time*1 (Operation at PCLKD = 8 MHz)	Permissible signal source impedance (Max.) = 5.0 k Ω	4.875 (1.250)*2	—	—	μs	High-precision channel ADCSR.ADHSC bit = 0 ADSSTRn.SST[7:0] bits = 09h
		6.250 (2.625)*2	—	—	μs	Normal-precision channel ADCSR.ADHSC bit = 0 ADSSTRn.SST[7:0] bits = 14h
Analog input effective range		0	—	VREFH0	V	
Offset error		—	± 0.5	± 24.0	LSB	
Full-scale error		—	± 1.25	± 24.0	LSB	
Quantization error		—	± 0.5	—	LSB	
Absolute accuracy		—	± 2.75	± 32.0	LSB	
DNL differential nonlinearity error		—	± 1.0	—	LSB	
INL integral nonlinearity error		—	± 1.25	± 12.0	LSB	

Note: • The characteristics apply when no pin functions other than A/D converter input are used. Absolute accuracy includes quantization errors. Offset error, full-scale error, DNL differential nonlinearity error, and INL integral nonlinearity error do not include quantization errors.

Note 1. The conversion time is the sum of the sampling time and the comparison time. As the test conditions, the number of sampling states is indicated.

Note 2. The value in parentheses indicates the sampling time.

Table 5.41 A/D Converter Channel Classification

Classification	Channel	Conditions	Remarks
High-precision channel	AN000 to AN004, AN006	AVCC0 = 1.8 to 3.6 V	Pins AN000 to AN004 and AN006 cannot be used as digital outputs when the A/D converter is in use.
Normal-precision channel	AN008 to AN015		
Internal reference voltage input channel	Internal reference voltage	AVCC0 = 2.0 to 3.6 V	
Temperature sensor input channel	Temperature sensor output	AVCC0 = 2.0 to 3.6 V	

Table 5.42 A/D Internal Reference Voltage Characteristics

Conditions: $2.0\text{ V} \leq VCC = VCC_USB \leq 3.6\text{ V}$, $2.0\text{ V} \leq AVCC0 \leq 3.6\text{ V}^{*1}$, $VSS = AVSS0 = VREFL0 = VSS_USB = 0\text{ V}$, $T_a = -40$ to $+105^\circ\text{C}$

Item	Min.	Typ.	Max.	Unit	Test Conditions
Internal reference voltage input channel*2	1.36	1.43	1.50	V	

Note 1. The internal reference voltage cannot be selected for input channels when $AVCC0 < 2.0\text{ V}$.

Note 2. The A/D internal reference voltage indicates the voltage when the internal reference voltage is input to the A/D converter.



Figure 5.57 Illustration of A/D Converter Characteristic Terms

Absolute accuracy

Absolute accuracy is the difference between output code based on the theoretical A/D conversion characteristics, and the actual A/D conversion result. When measuring absolute accuracy, the voltage at the midpoint of the width of analog input voltage (1-LSB width), that can meet the expectation of outputting an equal code based on the theoretical A/D conversion characteristics, is used as an analog input voltage. For example, if 12-bit resolution is used and if reference voltage ($V_{REFH0} = 3.072 \text{ V}$), then 1-LSB width becomes 0.75 mV, and 0 mV, 0.75 mV, 1.5 mV, ... are used as analog input voltages.

If analog input voltage is 6 mV, absolute accuracy = $\pm 5 \text{ LSB}$ means that the actual A/D conversion result is in the range of 003h to 00Dh though an output code, 008h, can be expected from the theoretical A/D conversion characteristics.

Integral nonlinearity error (INL)

Integral nonlinearity error is the maximum deviation between the ideal line when the measured offset and full-scale errors are zeroed, and the actual output code.

Differential nonlinearity error (DNL)

Differential nonlinearity error is the difference between 1-LSB width based on the ideal A/D conversion characteristics and the width of the actually output code.

Offset error

Offset error is the difference between a transition point of the ideal first output code and the actual first output code.

Full-scale error

Full-scale error is the difference between a transition point of the ideal last output code and the actual last output code.

5.6 D/A Conversion Characteristics

Table 5.43 D/A Conversion Characteristics

Conditions: $1.8\text{ V} \leq VCC = VCC_USB \leq 3.6\text{ V}$, $1.8\text{ V} \leq AVCC0 \leq 3.6\text{ V}$, $VSS = AVSS0 = VSS_USB = 0\text{ V}$, $fPCLKB \leq 32\text{ MHz}$,
 $T_a = -40\text{ to }+105^\circ\text{C}$

Item	Min.	Typ.	Max.	Unit	Test Conditions
Resolution	—	—	8	Bit	
Conversion time	$VCC = 2.7\text{ to }3.6\text{ V}$	—	3.0	μs	35-pF capacitive load
	$VCC = 1.6\text{ to }2.7\text{ V}$	—	6.0		
Absolute accuracy	$VCC = 2.4\text{ to }3.6\text{ V}$	—	± 3.0	LSB	2-M Ω resistive load
	$VCC = 1.8\text{ to }2.4\text{ V}$	—	± 3.5		
	$VCC = 2.4\text{ to }3.6\text{ V}$	—	± 2.0	LSB	4-M Ω resistive load
	$VCC = 1.8\text{ to }2.4\text{ V}$	—	± 2.5		
RO output resistance	—	6.4	—	k Ω	

5.7 Temperature Sensor Characteristics

Table 5.44 Temperature Sensor Characteristics

Conditions: $2.0\text{ V} \leq VCC = VCC_USB \leq 3.6\text{ V}$, $2.0\text{ V} \leq AVCC0 \leq 3.6\text{ V}$, $VSS = AVSS0 = VSS_USB = 0\text{ V}$, $T_a = -40\text{ to }+105^\circ\text{C}$

Item	Symbol	Min.	Typ.	Max.	Unit	Test Conditions
Relative accuracy	—	—	± 1.5	—	$^\circ\text{C}$	2.4 V or above
		—	± 2.0	—		Below 2.4 V
Temperature slope	—	—	-3.65	—	mV/ $^\circ\text{C}$	
Output voltage (at 25 $^\circ\text{C}$)	—	—	1.05	—	V	$VCC = 3.3\text{ V}$
Temperature sensor start time	t_{START}	—	—	5	μs	
Sampling time	—	5	—	—	μs	

5.8 Power-On Reset Circuit and Voltage Detection Circuit Characteristics

Table 5.45 Power-On Reset Circuit and Voltage Detection Circuit Characteristics (1)Conditions: $1.8\text{ V} \leq \text{VCC} = \text{VCC_USB} \leq 3.6\text{ V}$, $1.8\text{ V} \leq \text{AVCC0} \leq 3.6\text{ V}$, $\text{VSS} = \text{AVSS0} = \text{VSS_USB} = 0\text{ V}$, $T_a = -40$ to $+105^\circ\text{C}$

Item	Symbol	Min.	Typ.	Max.	Unit	Test Conditions	
Voltage detection level	Power-on reset (POR)	V_{POR}	1.35	1.50	1.65	V	Figure 5.58, Figure 5.59
	Voltage detection circuit (LVD1)*1	$V_{\text{det1_4}}$	3.00	3.10	3.20	V	Figure 5.60 At falling edge VCC
$V_{\text{det1_5}}$		2.91	3.00	3.09			
$V_{\text{det1_6}}$		2.81	2.90	2.99			
$V_{\text{det1_7}}$		2.70	2.79	2.88			
$V_{\text{det1_8}}$		2.60	2.68	2.76			
$V_{\text{det1_9}}$		2.50	2.58	2.66			
$V_{\text{det1_A}}$		2.40	2.48	2.56			
$V_{\text{det1_B}}$		1.99	2.06	2.13			
$V_{\text{det1_C}}$		1.90	1.96	2.02			
	$V_{\text{det1_D}}$	1.80	1.86	1.92			

Note: • These characteristics apply when noise is not superimposed on the power supply. When a setting is made so that the voltage detection level overlaps with that of the voltage detection circuit (LVD2), it cannot be specified which of LVD1 and LVD2 is used for voltage detection.

Note 1. n in the symbol $V_{\text{det1_n}}$ denotes the value of the LVDLVL[3:0] bits.

Table 5.46 Power-On Reset Circuit and Voltage Detection Circuit Characteristics (2)Conditions: $1.8\text{ V} \leq \text{VCC} = \text{VCC_USB} \leq 3.6\text{ V}$, $1.8\text{ V} \leq \text{AVCC0} \leq 3.6\text{ V}$, $\text{VSS} = \text{AVSS0} = \text{VSS_USB} = 0\text{ V}$, $T_a = -40$ to $+105^\circ\text{C}$

Item	Symbol	Min.	Typ.	Max.	Unit	Test Conditions	
Voltage detection level	Voltage detection circuit (LVD2)*1	$V_{\text{det2_0}}$	2.71	2.90	3.09	V	Figure 5.61 At falling edge VCC
		$V_{\text{det2_1}}$	2.43	2.60	2.77		
		$V_{\text{det2_2}}$	1.87	2.00	2.13		
		$V_{\text{det2_3}}^*2$	1.69	1.80	1.91		
Wait time after power-on reset cancellation	At normal startup*3	t_{POR}	—	9.1	—	ms	Figure 5.59
	During fast startup time*4	t_{POR}	—	1.6	—		
Wait time after voltage monitoring 1 reset cancellation	Power-on voltage monitoring 1 reset disabled*3	t_{LVD1}	—	568	—	μs	Figure 5.60
	Power-on voltage monitoring 1 reset enabled*4		—	100	—		
Wait time after voltage monitoring 2 reset cancellation		t_{LVD2}	—	100	—	μs	Figure 5.61
Response delay time		t_{det}	—	—	350	μs	Figure 5.58
Minimum VCC down time*5		t_{VOFF}	350	—	—	μs	Figure 5.58, VCC = 1.0 V or above
Power-on reset enable time		$t_{\text{W(POR)}}$	1	—	—	ms	Figure 5.59, VCC = below 1.0 V
LVD operation stabilization time (after LVD is enabled)		$T_{\text{d(E-A)}}$	—	—	300	μs	Figure 5.60, Figure 5.61
Hysteresis width (LVD1 and LVD2)		V_{LVH}	—	70	—	mV	Vdet1_4 selected
			—	60	—		Vdet1_5 to 9, LVD2 selected
			—	50	—		When selection is from among Vdet1_A to B.
			—	40	—		When selection is from among Vdet1_C to D.

Note: • These characteristics apply when noise is not superimposed on the power supply. When a setting is made so that the voltage detection level overlaps with that of the voltage detection circuit (LVD1), it cannot be specified which of LVD1 and LVD2 is used for voltage detection.

Note 1. n in the symbol $V_{\text{det2_n}}$ denotes the value of the LVDLVL[3:0] bits.

Note 2. $V_{\text{det2_3}}$ selection can be used only when the CMPA2 pin input voltage is selected and cannot be used when the power supply voltage (VCC) is selected.

Note 3. When OFS1.(STUPLVD1REN, FASTSTUP) = 11b.

Note 4. When OFS1.(STUPLVD1REN, FASTSTUP) \neq 11b.

Note 5. The minimum VCC down time indicates the time when VCC is below the minimum value of voltage detection levels V_{POR} , V_{det0} , V_{det1} , and V_{det2} for the POR/LVD.

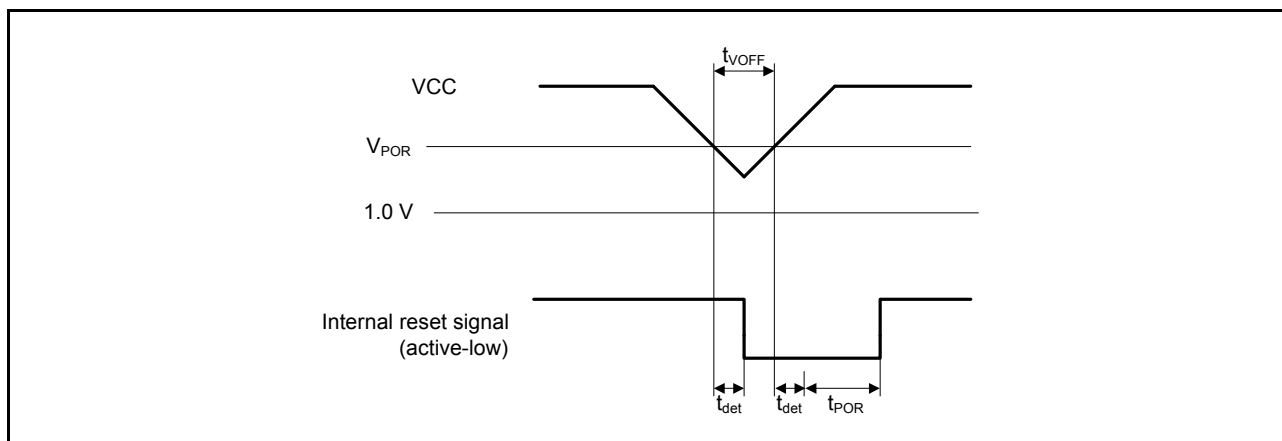
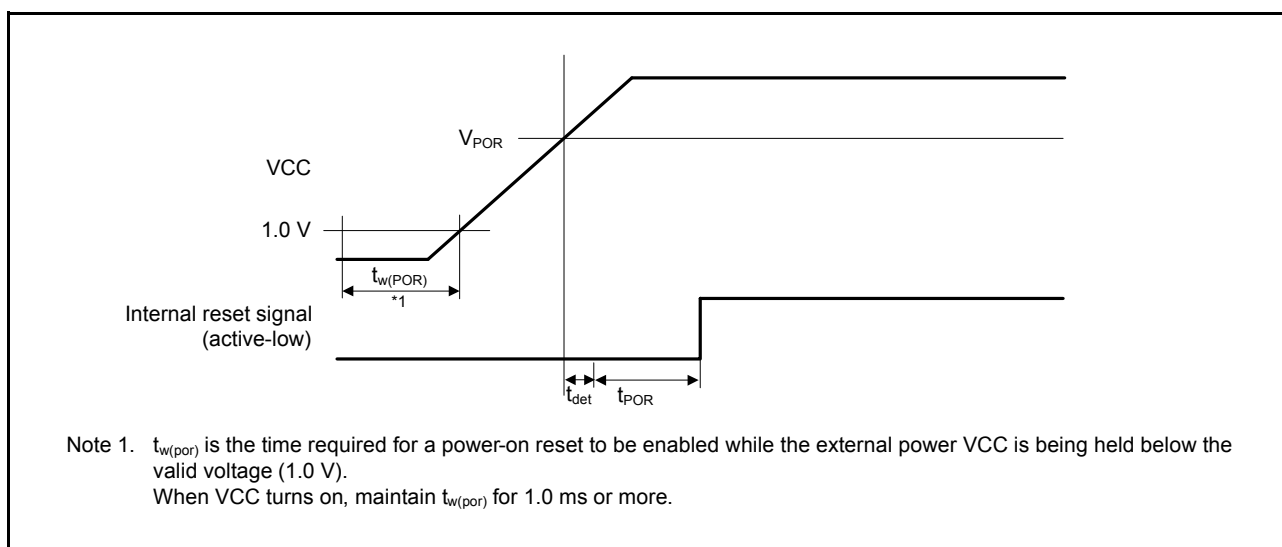

Figure 5.58 Voltage Detection Reset Timing



Note 1. $t_{w(POR)}$ is the time required for a power-on reset to be enabled while the external power VCC is being held below the valid voltage (1.0 V).
When VCC turns on, maintain $t_{w(POR)}$ for 1.0 ms or more.

Figure 5.59 Power-On Reset Timing

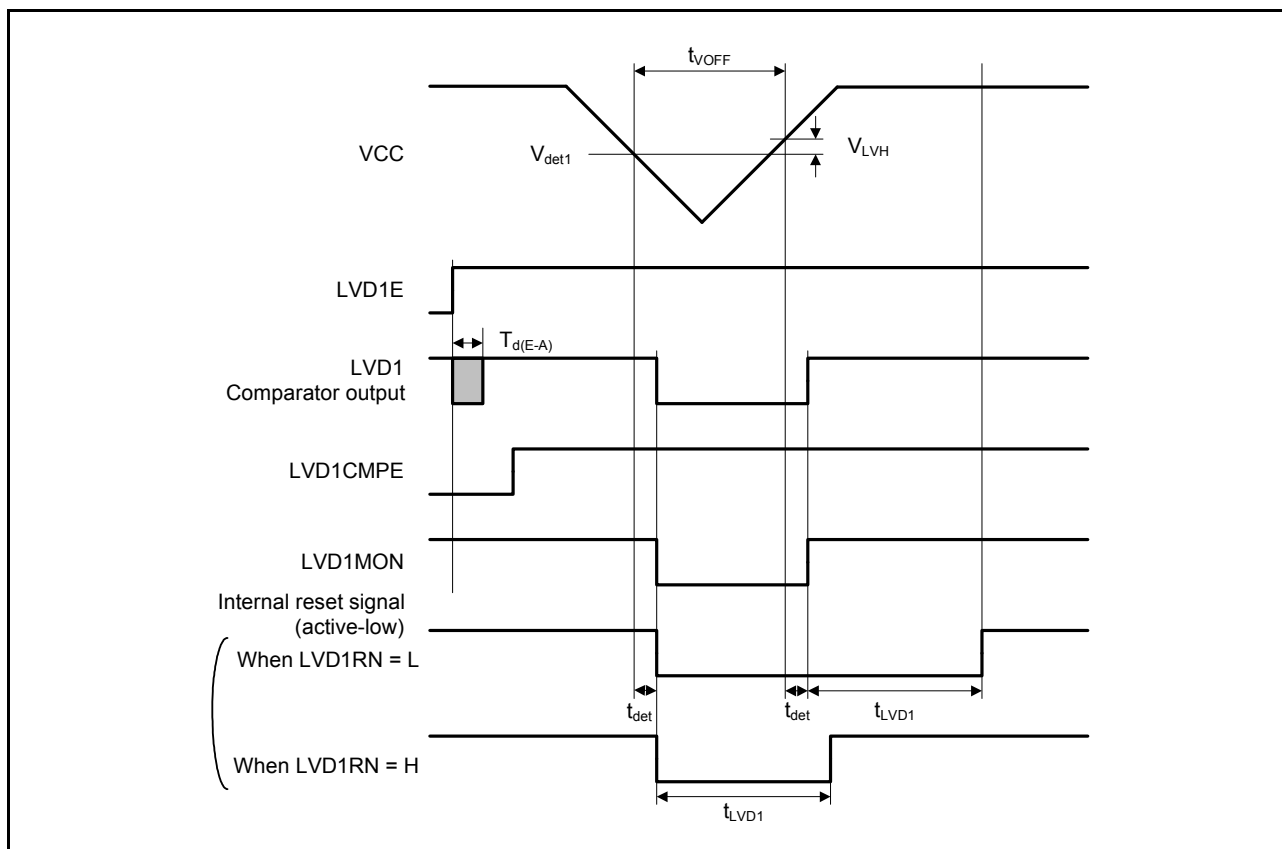

Figure 5.60 Voltage Detection Circuit Timing (V_{det1})

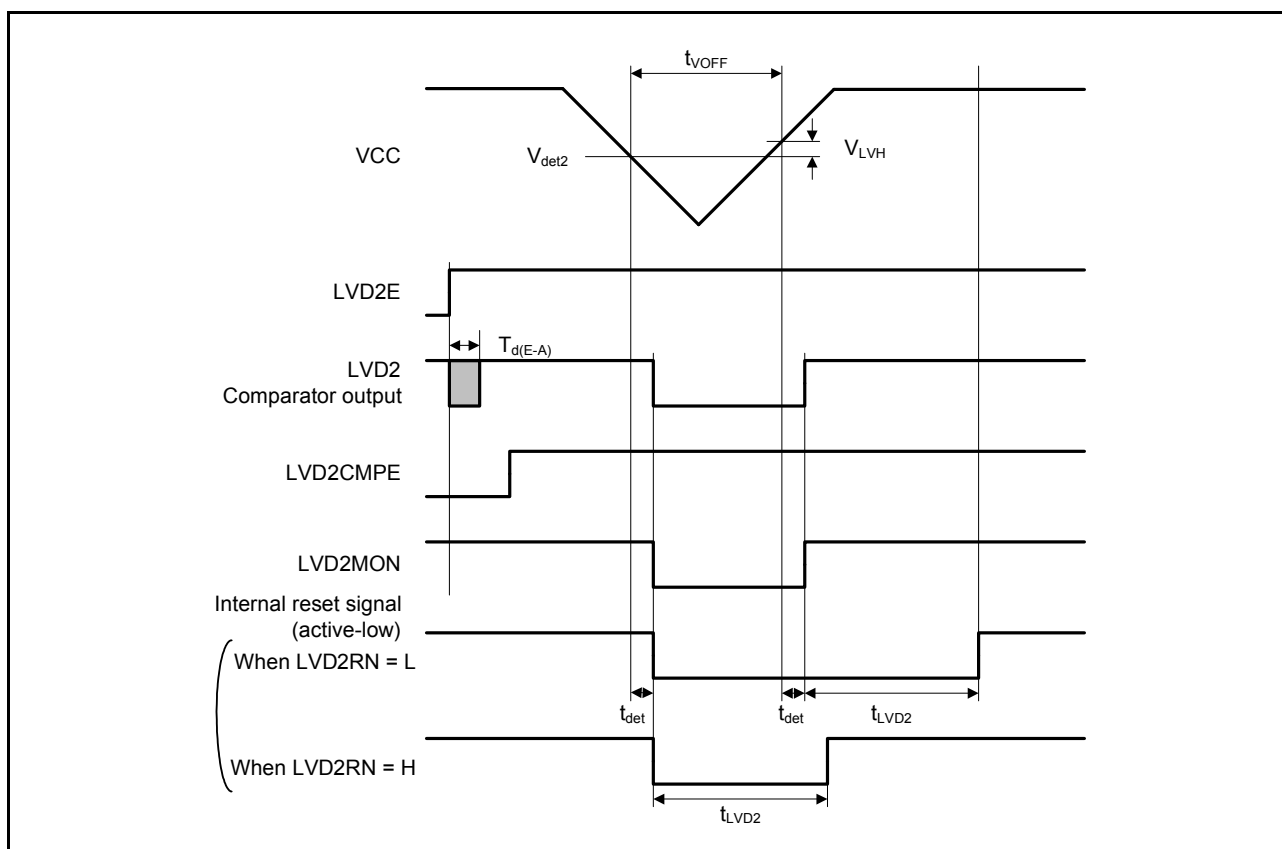

Figure 5.61 Voltage Detection Circuit Timing (V_{det2})

5.9 Oscillation Stop Detection Timing

Table 5.47 Oscillation Stop Detection Circuit Characteristics

Conditions: $1.8\text{ V} \leq VCC = VCC_USB \leq 3.6\text{ V}$, $1.8\text{ V} \leq AVSS0 \leq 3.6\text{ V}$, $VSS = AVSS0 = VSS_USB = 0\text{ V}$, $T_a = -40\text{ to }+105^\circ\text{C}$

Item	Symbol	Min.	Typ.	Max.	Unit	Test Conditions
Detection time	t_{dr}	—	—	1	ms	Figure 5.62

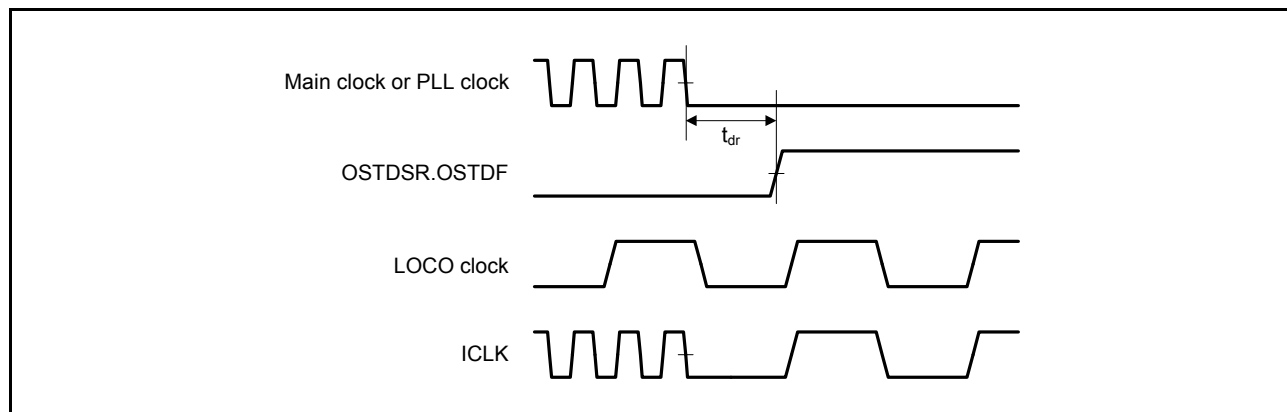

Figure 5.62 Oscillation Stop Detection Timing

5.10 ROM (Flash Memory for Code Storage) Characteristics

Table 5.48 ROM (Flash Memory for Code Storage) Characteristics (1)

Item	Symbol	Min.	Typ.	Max.	Unit	Conditions
Reprogramming/erasure cycle*1	N_{PEC}	1000	—	—	Times	
Data hold time	After 1000 times of N_{PEC}	t_{DRP}	20*2, *3	—	Year	$T_a = +85^\circ\text{C}$

Note 1. Definition of reprogram/erase cycle: The reprogram/erase cycle is the number of erasing for each block. When the reprogram/erase cycle is n times ($n = 1000$), erasing can be performed n times for each block. For instance, when 4-byte programming is performed 256 times for different addresses in 1-Kbyte block and then the entire block is erased, the reprogram/erase cycle is counted as one. However, programming the same address for several times as one erasing is not enabled (overwriting is prohibited).

Note 2. Characteristic when using the flash memory programmer and the self-programming library provided from Renesas Electronics.

Note 3. This result is obtained from reliability testing.

Table 5.49 ROM (Flash Memory for Code Storage) Characteristics (2)

High-speed operating mode Conditions: $2.7\text{ V} \leq V_{CC} \leq 3.6\text{ V}$, $2.7\text{ V} \leq AVSS0 \leq 3.6\text{ V}$, $V_{SS} = AVSS0 = V_{SS_USB} = 0\text{ V}$

Temperature range for the programming/erasure operation: $T_a = -40$ to $+105^\circ\text{C}$

Item	Symbol	FCLK = 1 MHz			FCLK = 32 MHz			Unit	
		Min.	Typ.	Max.	Min.	Typ.	Max.		
Programming time	4-byte	t_{P4}	—	103	931	—	52	489	μs
Erasure time	1-Kbyte	t_{E1K}	—	8.23	267	—	5.48	214	ms
	256-Kbyte	t_{E256K}	—	407	925	—	39	457	ms
Blank check time	4-byte	t_{BC4}	—	—	48	—	—	15.9	μs
	1-Kbyte	t_{BC1K}	—	—	1.58	—	—	0.127	ms
Erase operation forcible stop time		t_{SED}	—	—	21.6	—	—	12.8	μs
Start-up area switching setting time		t_{SAS}	—	12.6	543	—	6.16	432	ms
Access window time		t_{AWS}	—	12.6	543	—	6.16	432	ms
ROM mode transition wait time 1		t_{DIS}	2	—	—	2	—	—	μs
ROM mode transition wait time 2		t_{MS}	5	—	—	5	—	—	μs

Note: • Does not include the time until each operation of the flash memory is started after instructions are executed by software.

Note: • The lower-limit frequency of FCLK is 1 MHz during programming or erasing of the flash memory. When using FCLK at below 4 MHz, the frequency can be set to 1 MHz, 2 MHz, or 3 MHz. A non-integer frequency such as 1.5 MHz cannot be set.

Note: • The frequency accuracy of FCLK should be $\pm 3.5\%$. Confirm the frequency accuracy of the clock source.

Table 5.50 ROM (Flash Memory for Code Storage) Characteristics (3)Middle-speed operating mode Conditions: $1.8\text{ V} \leq \text{VCC} \leq 3.6\text{ V}$, $1.8\text{ V} \leq \text{AVSS0} \leq 3.6\text{ V}$, $\text{VSS} = \text{AVSS0} = \text{VSS_USB} = 0\text{ V}$ Temperature range for the programming/erasure operation: $T_a = -40$ to $+85^\circ\text{C}$

Item		Symbol	FCLK = 1 MHz			FCLK = 8 MHz			Unit
			Min.	Typ.	Max.	Min.	Typ.	Max.	
Programming time	4-byte	t_{P4}	—	143	1330	—	96.8	932	μs
Erasure time	1-Kbyte	t_{E1K}	—	8.3	269	—	5.85	219	ms
	256-Kbyte	t_{E256K}	—	407	928	—	93	520	ms
Blank check time	4-byte	t_{BC4}	—	—	78	—	—	50	μs
	1-Kbyte	t_{BC1K}	—	—	1.61	—	—	0.369	ms
Erase operation forcible stop time		t_{SED}	—	—	33.6	—	—	25.6	μs
Start-up area switching setting time		t_{SAS}	—	13.2	549	—	7.6	445	ms
Access window time		t_{AWS}	—	13.2	549	—	7.6	445	ms
ROM mode transition wait time 1		t_{DIS}	2	—	—	2	—	—	μs
ROM mode transition wait time 2		t_{MS}	3	—	—	3	—	—	μs

Note: • Does not include the time until each operation of the flash memory is started after instructions are executed by software.

Note: • The lower-limit frequency of FCLK is 1 MHz during programming or erasing of the flash memory. When using FCLK at below 4 MHz, the frequency can be set to 1 MHz, 2 MHz, or 3 MHz. A non-integer frequency such as 1.5 MHz cannot be set.

Note: • The frequency accuracy of FCLK should be $\pm 3.5\%$. Confirm the frequency accuracy of the clock source.

5.11 E2 DataFlash Characteristics

Table 5.51 E2 DataFlash Characteristics (1)

Item		Symbol	Min.	Typ.	Max.	Unit	Conditions
Reprogramming/erasure cycle*1		N_{DPEC}	100000	1000000	—	Times	
Data hold time	After 10000 times of N_{DPEC}	t_{DDRP}	20*2, *3	—	—	Year	$T_a = +85^{\circ}\text{C}$
	After 100000 times of N_{DPEC}		5*2, *3	—	—	Year	
	After 1000000 times of N_{DPEC}		—	1*2, *3	—	Year	$T_a = +25^{\circ}\text{C}$

Note 1. The reprogram/erase cycle is the number of erasing for each block. When the reprogram/erase cycle is n times ($n = 100000$), erasing can be performed n times for each block. For instance, when 1-byte programming is performed 1000 times for different addresses in 1-byte block and then the entire block is erased, the reprogram/erase cycle is counted as one. However, programming the same address for several times as one erasing is not enabled (overwriting is prohibited).

Note 2. Characteristics when using the flash memory programmer and the self-programming library provided from Renesas Electronics.

Note 3. These results are obtained from reliability testing.

**Table 5.52 E2 DataFlash Characteristics (2)
: high-speed operating mode**

Conditions: $2.7\text{ V} \leq V_{CC} \leq 3.6\text{ V}$, $2.7\text{ V} \leq AV_{SS0} \leq 3.6\text{ V}$, $V_{SS} = AV_{SS0} = V_{SS_USB} = 0\text{ V}$

Temperature range for the programming/erasure operation: $T_a = -40$ to $+105^{\circ}\text{C}$

Item		Symbol	FCLK = 1 MHz			FCLK = 32 MHz			Unit
			Min.	Typ.	Max.	Min.	Typ.	Max.	
Programming time	1-byte	t_{DP1}	—	86	761	—	40.5	374	μs
Erasure time	1-Kbyte	t_{DE1K}	—	17.4	456	—	6.15	228	ms
	8-Kbyte	t_{DE8K}	—	60.4	499	—	9.3	231	ms
Blank check time	1-byte	t_{DBC1}	—	—	48	—	—	15.9	μs
	1-Kbyte	t_{DBC1K}	—	—	1.58	—	—	0.127	μs
Erase operation forcible stop time		t_{DSED}	—	—	21.5	—	—	12.8	μs
DataFlash STOP recovery time		t_{DSTOP}	5	—	—	5	—	—	μs

Note: • Does not include the time until each operation of the flash memory is started after instructions are executed by software.

Note: • The lower-limit frequency of FCLK is 1 MHz during programming or erasing of the flash memory. When using FCLK at below 4 MHz, the frequency can be set to 1 MHz, 2 MHz, or 3 MHz. A non-integer frequency such as 1.5 MHz cannot be set.

Note: • The frequency accuracy of FCLK should be $\pm 3.5\%$. Confirm the frequency accuracy of the clock source.

**Table 5.53 E2 DataFlash Characteristics (3)
: middle-speed operating mode**

Conditions: $1.8\text{ V} \leq V_{CC} \leq 3.6\text{ V}$, $1.8\text{ V} \leq AV_{SS0} \leq 3.6\text{ V}$, $V_{SS} = AV_{SS0} = V_{SS_USB} = 0\text{ V}$

Temperature range for the programming/erasure operation: $T_a = -40$ to $+85^{\circ}\text{C}$

Item		Symbol	FCLK = 1 MHz			FCLK = 8 MHz			Unit
			Min.	Typ.	Max.	Min.	Typ.	Max.	
Programming time	1-byte	t_{DP1}	—	126	1160	—	85.4	818	μs
Erasure time	1-Kbyte	t_{DE1K}	—	17.5	457	—	7.76	259	ms
	8-Kbyte	t_{DE8K}	—	60.5	500	—	16.7	267.6	ms
Blank check time	1-byte	t_{DBC1}	—	—	78	—	—	50	μs
	1-Kbyte	t_{DBC1K}	—	—	1.61	—	—	0.369	ms
Erase operation forcible stop time		t_{DSED}	—	—	33.5	—	—	25.5	μs
DataFlash STOP recovery time		t_{DSTOP}	720	—	—	720	—	—	ns

Note: • Does not include the time until each operation of the flash memory is started after instructions are executed by software.

Note: • The lower-limit frequency of FCLK is 1 MHz during programming or erasing of the flash memory. When using FCLK at below 4 MHz, the frequency can be set to 1 MHz, 2 MHz, or 3 MHz. A non-integer frequency such as 1.5 MHz cannot be set.

Note: • The frequency accuracy of FCLK should be $\pm 3.5\%$. Confirm the frequency accuracy of the clock source.

5.12 Usage Notes

5.12.1 Connecting VCL Capacitor and Bypass Capacitors

This MCU integrates an internal voltage-down circuit, which is used for lowering the power supply voltage in the internal MCU to adjust automatically to the optimum level. A 4.7- μF capacitor needs to be connected between this internal voltage-down power supply (VCL pin) and VSS pin. Figure 5.63 to Figure 5.64 shows how to connect external capacitors. Place an external capacitor close to the pins. Do not apply the power supply voltage to the VCL pin. Insert a multilayer ceramic capacitor as a bypass capacitor between each pair of the power supply pins. Implement a bypass capacitor to the MCU power supply pins as close as possible. Use a recommended value of 0.1 μF as the capacitance of the capacitors. For the capacitors related to crystal oscillation, see section 9, Clock Generation Circuit in the User's Manual: Hardware. For the capacitors related to analog modules, also see section 30, 12-Bit A/D Converter (S12ADb) in the User's Manual: Hardware.

For notes on designing the printed circuit board, see the descriptions of the application note "Hardware Design Guide" (R01AN1411EJ). The latest version can be downloaded from Renesas Electronics Website.



Figure 5.63 Connecting Capacitors (64 Pins)



Figure 5.64 Connecting Capacitors (48-pin LQFP)

Appendix 1. Package Dimensions

Information on the latest version of the package dimensions or mountings has been displayed in “Packages” on Renesas Electronics Corporation website.



Figure A 64-Pin LFQFP (PLQP0064KB-A)

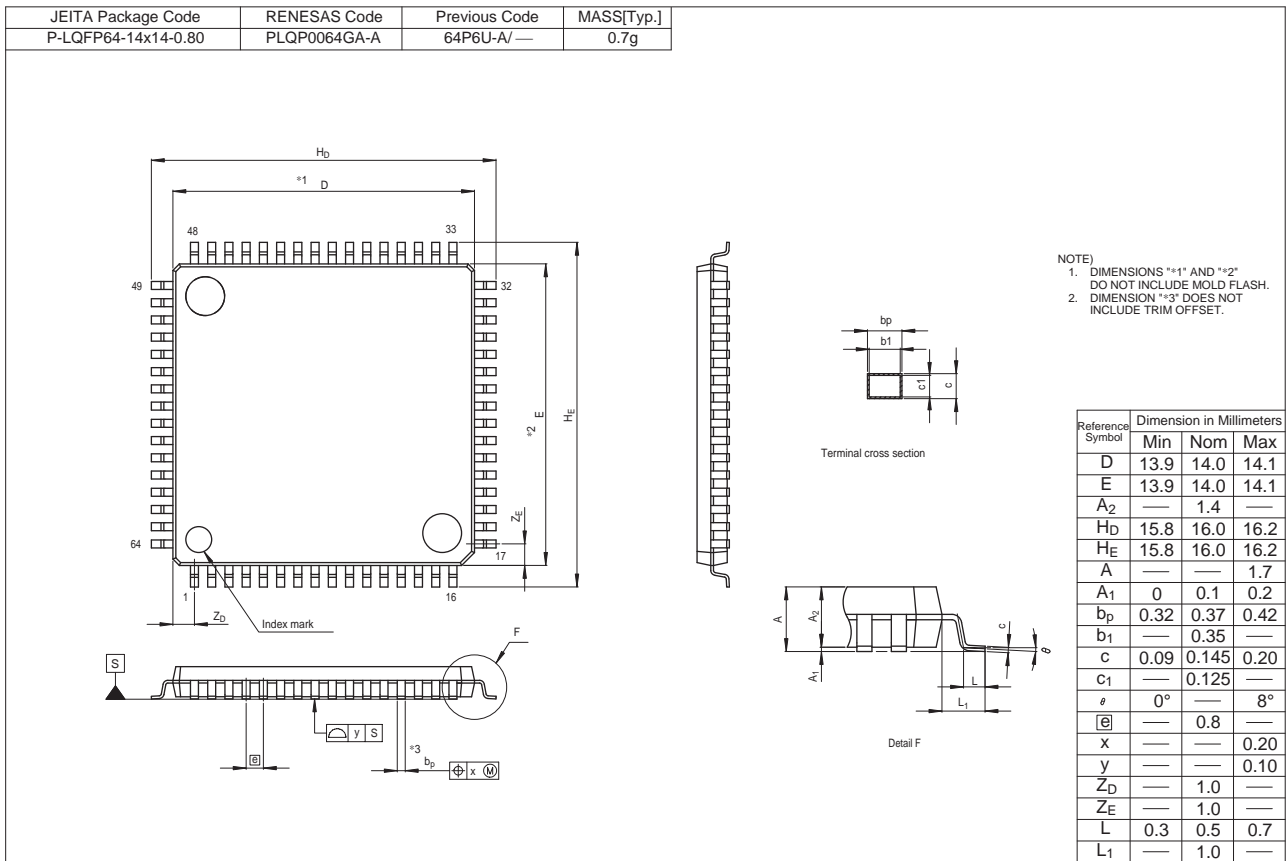

Figure B 64-Pin LQFP (PLQP0064GA-A)



Figure C 64-Pin WFLGA (PWL0064KA-A)

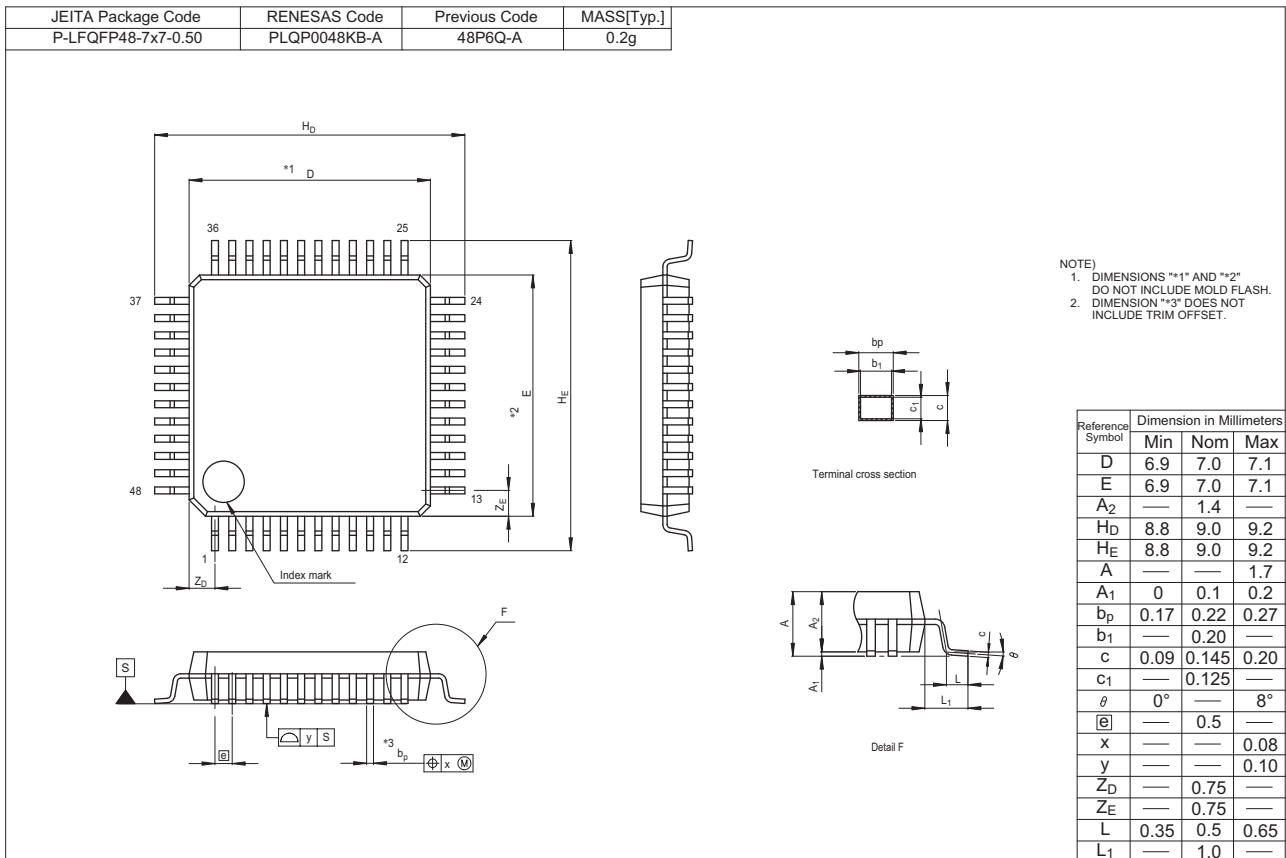

Figure D 48-Pin LFQFP (PLQP0048KB-A)

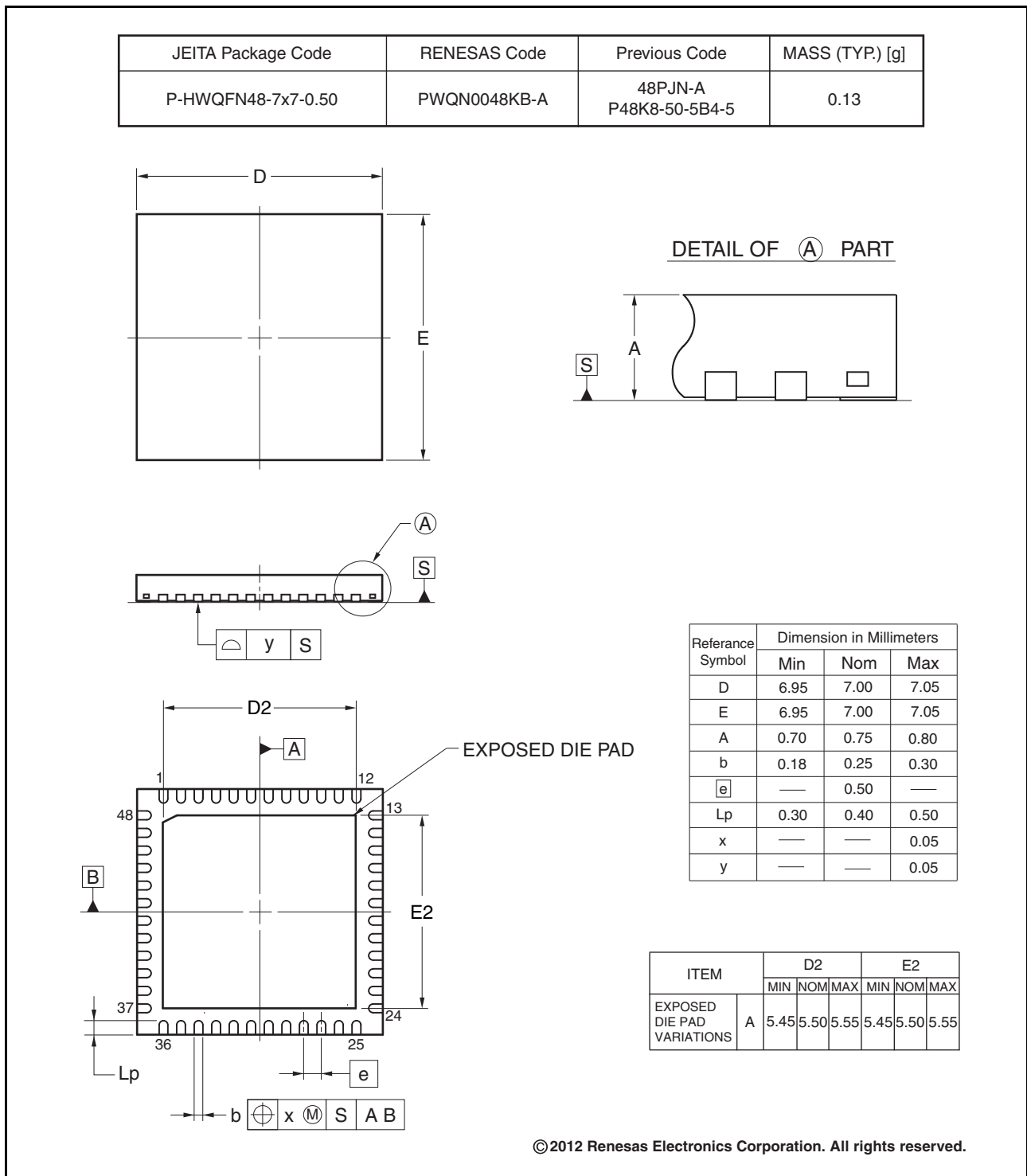

Figure E 48-Pin HWQFN (PWQN0048KB-A)

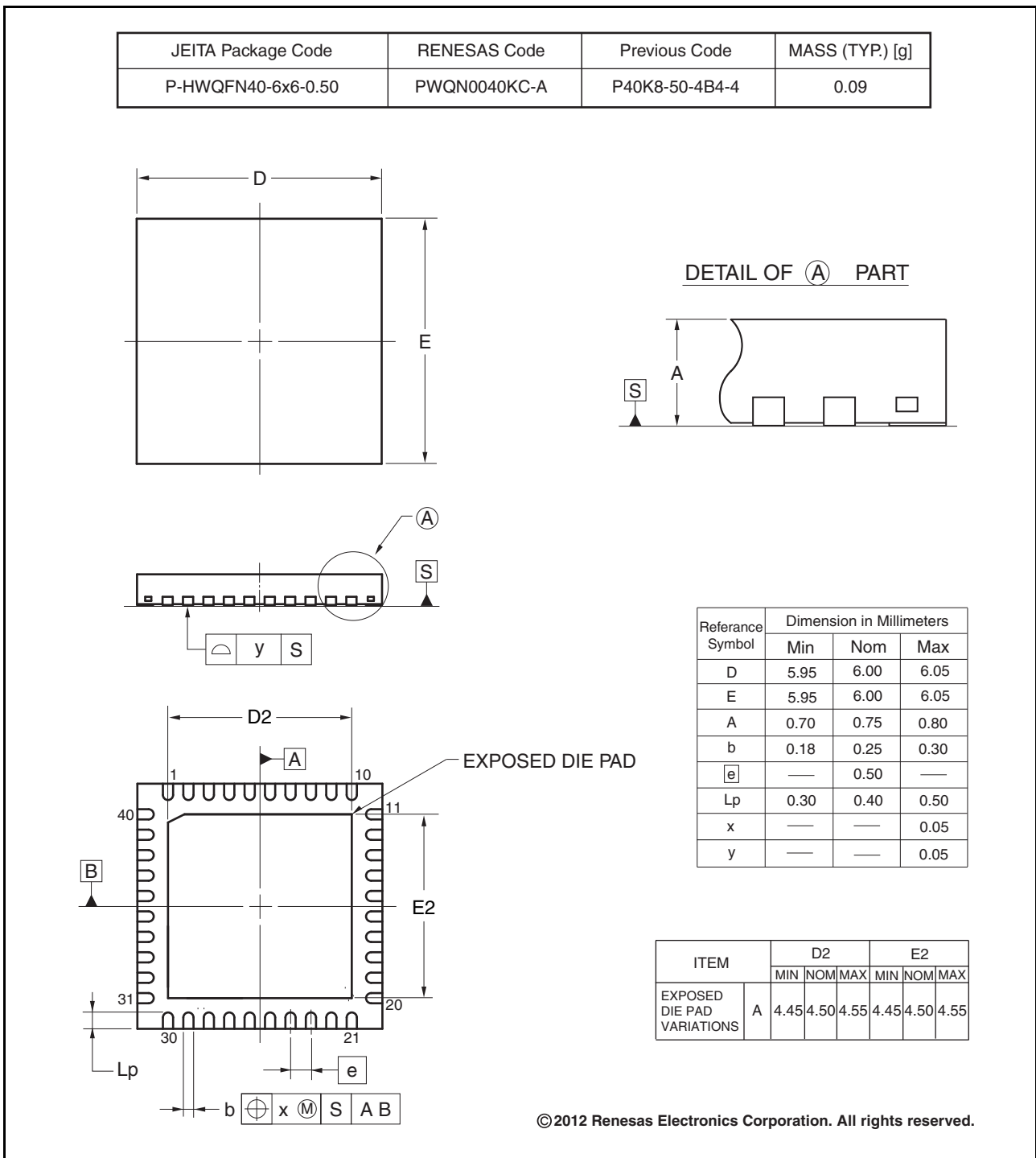

Figure F 40-Pin HWQFN (PWQN0040KC-A)

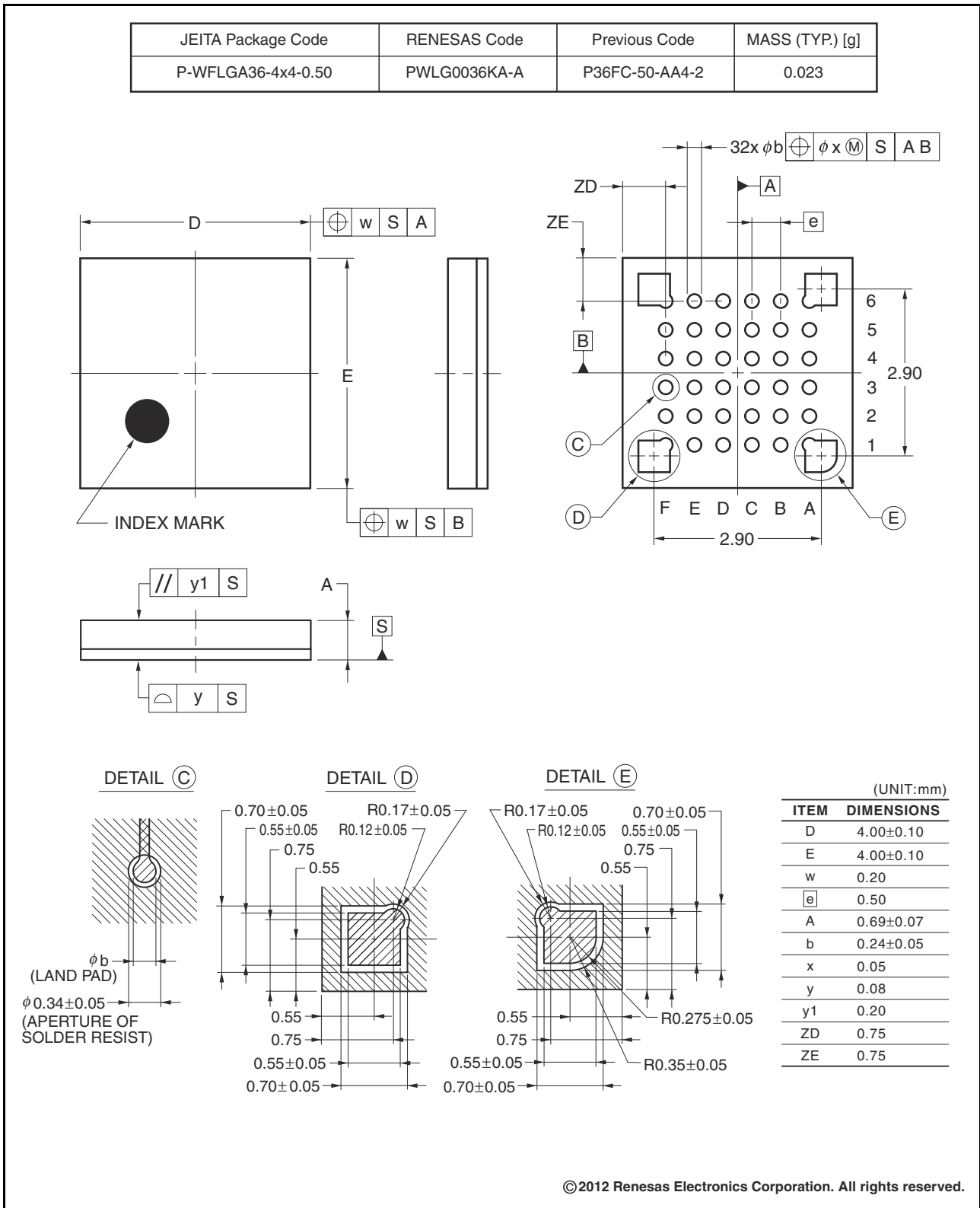

Figure G 36-Pin WFLGA (PWLG0036KA-A)

REVISION HISTORY	RX111 Group Datasheet
------------------	-----------------------

Rev.	Date	Description	
		Page	Summary
0.60	Apr 15, 2013	—	First edition, issued
0.90	May 15, 2013	Features	
		1	Changed
		1. Overview	
		2 to 4	Table 1.1 Outline of Specifications changed
		10 to 12	Table 1.4 Pin Functions changed
		13	Figure 1.3 Pin Assignments of the 64-Pin LQFP changed
		14	Figure 1.4 Pin Assignments of the 64-Pin WFLGA changed
		15	Figure 1.5 Pin Assignments of the 48-Pin LQFP/HWQFN changed
		18, 19	Table 1.5 List of Pins and Pin Functions (64-Pin LQFP) changed, Note 1 added
		20, 21	Table 1.6 List of Pins and Pin Functions (64-Pin WFLGA) changed, Note 1 added
		22, 23	Table 1.7 List of Pins and Pin Functions (48-Pin LQFP/HWQFN) changed, Note 1 added
		24, 25	Table 1.8 List of Pins and Pin Functions (40-Pin HWQFN) changed, Note 1 added
		26	Table 1.9 List of Pins and Pin Functions (36-Pin WFLGA) changed, Note 1 added
		4. I/O Registers	
33 to 48	Table 5.1 List of I/O Registers (Address Order) changed		
1.00	Jun 19, 2013	1. Overview	
		9	Figure 1.2 Block Diagram changed
		20, 21	Table 1.6 List of Pins and Pin Functions (64-Pin WFLGA) changed
		26	Table 1.9 List of Pins and Pin Functions (36-Pin WFLGA) changed
		4. I/O Registers	
		33 to 48	Table 4.1 List of I/O Registers (Address Order) changed
		5. Electrical Characteristics	
49 to 99	Added		
1.20	Sep 29, 2014	1. Overview	
		2 to 4	Table 1.1 Outline of Specifications: ROM capacity and RAM capacity changed, Unique ID added
		6, 7	Table 1.3 List of Products, changed
		8	Figure 1.1 How to Read the Product Part No., Memory Capacity, and Package Type, changed
		9	Figure 1.2 Block Diagram changed
		10	Table 1.4 Pin Functions changed
		15	Figure 1.5 Pin Assignments of the 48-Pin LQFP/HWQFN: Note added
		16	Figure 1.6 Pin Assignments of the 40-Pin HWQFN: Note added
		3. Address Space	
		30	Figure 3.1 Memory Map, changed
		4. I/O Registers	
		33 to 48	Table 4.1 List of I/O Registers (Address Order), changed
		5. Electrical Characteristics	
		49	Table 5.1 Absolute Maximum Ratings, Table 5.2 Recommended Operating Conditions, changed
		50	Table 5.3 DC Characteristics (1) and Table 5.4 DC Characteristics (2), changed
		51	Table 5.5 DC Characteristics (3), changed
		55, 56	Table 5.8 DC Characteristics (6), added
		56	Table 5.9 DC Characteristics (7), changed
		58	Table 5.10 DC Characteristics (8), added
		59	Table 5.13 DC Characteristics (11), changed
		61	Table 5.19 Output Values of Voltage (1) and Table 5.20 Output Values of Voltage (2), changed
		68	Table 5.22 Operation Frequency Value (Middle-Speed Operating Mode) changed, Note 4 added
		69	Table 5.24 Clock Timing, changed
78	Table 5.32 Timing of On-Chip Peripheral Modules (1) changed		
81	Table 5.35 Timing of On-Chip Peripheral Modules (4), changed		
82	Table 5.36 Timing of On-Chip Peripheral Modules (5): Note 2 deleted		
83	Figure 5.37 SCK Clock Input Timing changed		
84	Figure 5.38 SCI Input/Output Timing: Clock Synchronous Mode changed		

Rev.	Date	Description	
		Page	Summary
1.20	Sep 29, 2014	85	Figure 5.41 RSPI Clock Timing and Simple SPI Clock Timing, Figure 5.42 RSPI Timing (Master, CPHA = 0) (Bit Rate: PCLKB Set to Division Ratio Other Than Divided by 2) and Simple SPI Timing (Master, CKPH = 1) changed
		86	Figure 5.43 RSPI Timing (Master, CPHA = 0) (Bit Rate: PCLKB Set to Divided by 2) added, Figure 5.44 RSPI Timing (Master, CPHA = 1) (Bit Rate: PCLKB Set to Division Ratio Other Than Divided by 2) and Simple SPI Timing (Master, CKPH = 0) changed
		87	Figure 5.45 RSPI Timing (Master, CPHA = 1) (Bit Rate: PCLKB Set to Divided by 2) added, Figure 5.46 RSPI Timing (Slave, CPHA = 0) and Simple SPI Timing (Slave, CKPH = 1) changed
		88	Figure 5.47 RSPI Timing (Slave, CPHA = 1) and Simple SPI Timing (Slave, CKPH = 0) changed
		89	Table 5.37 USB Characteristics (USB0_DP and USB0_DM Pin Characteristics) and Figure 5.49 USB0_DP and USB0_DM Output Timing, changed
		90	Figure 5.50 Test Circuit, changed
		91	Table 5.38 A/D Conversion Characteristics (1), Figure 5.51 AVCC0 to AVREFH0 Voltage Range, changed
		92	Table 5.39 A/D Conversion Characteristics (2), Table 5.40 A/D Conversion Characteristics (3) changed
		101	Table 5.49 ROM (Flash Memory for Code Storage) Characteristics (2) and Table 5.50 ROM (Flash Memory for Code Storage) Characteristics (3), changed
		102	Table 5.52 E2 DataFlash Characteristics (2), Table 5.53 E2 DataFlash Characteristics (3) changed
1.21	Dec 09, 2014	1. Overview	
		2 to 4	Table 1.1 Outline of Specifications Unique ID, changed
		5. Electrical Characteristics	
		51	Table 5.3 DC Characteristics (1) and Table 5.4 DC Characteristics (2), changed
		61	Table 5.19 Output Voltage (1) and Table 5.20 Output Voltage (2), changed
		102	Table 5.52 E2 DataFlash Characteristics (2): high-speed operating mode and Table 5.53 E2 DataFlash Characteristics (3): middle-speed operating mode, changed

Classifications

- Items with Technical Update document number: Changes according to the corresponding issued Technical Update

- Items without Technical Update document number: Minor changes that do not require Technical Update to be issued

Rev.	Date	Description		Classification
		Page	Summary	
1.30	May 31, 2016	1. Overview		
		18 to 26	Table 1.5 to 1.9 Note 2 regarding I/O power source is AVCC0 for the ports (P4, PJ6, and PJ7), added	
		5. Electrical Characteristics		
		49	Table 5.1 Absolute Maximum Ratings, Analog power supply voltage added	
		49	Table 5.2 Recommended Operating Conditions, VREFH0 / VREFL0 added	
		58	Figure 5.4 Voltage Dependency in High-Speed Operating Mode (Reference Data) added	
		59	Figure 5.5 Voltage Dependency in Middle-Speed Operating Mode (Reference Data) added	
		59	Figure 5.6 Voltage Dependency in Low-Speed Operating Mode (Reference Data) added	
		60	Table 5.9 DC Characteristics (7), Increment for IWDT operation added	
		62	Table 5.10 DC Characteristics (8), Increment for IWDT operation added	
		62	Figure 5.9 Voltage Dependency in Software Standby Mode (Reference Data) added	
		63	Figure 5.10 Temperature Dependency in Software Standby Mode (Reference Data) added	
		63	Table 5.11 DC Characteristics (9) added	TN-RX*-A134A/E
		64	Table 5.12 DC Characteristics (10), LDV1, 2 added	
		66, 67	Table 5.18 Permissible Output Currents is divided into D version and G version	TN-RX*-A134A/E
		110	Table 5.49 ROM (Flash Memory for Code Storage) Characteristics (2), Erasure time - 256-Kbyte added	TN-RX*-A132A/E
		111	Table 5.50 ROM (Flash Memory for Code Storage) Characteristics (3), Temperature range for the programming/erasure operation changed and Erasure time - 256-Kbyte added	TN-RX*-A132A/E
112	Table 5.52 E2 DataFlash Characteristics (2), Low speed FCLK changed and Erasure time - 8-Kbyte added	TN-RX*-A132A/E		
112	Table 5.53 E2 DataFlash Characteristics (3), Temperature range for the programming/erasure operation changed, Low speed FCLK changed and Erasure time - 8-Kbyte added	TN-RX*-A132A/E		
	113, 114	5.12 Usage Notes added		

All trademarks and registered trademarks are the property of their respective owners.

NOTES FOR CMOS DEVICES

- (1) **VOLTAGE APPLICATION WAVEFORM AT INPUT PIN:** Waveform distortion due to input noise or a reflected wave may cause malfunction. If the input of the CMOS device stays in the area between VIL (MAX) and VIH (MIN) due to noise, etc., the device may malfunction. Take care to prevent chattering noise from entering the device when the input level is fixed, and also in the transition period when the input level passes through the area between VIL (MAX) and VIH (MIN).
- (2) **HANDLING OF UNUSED INPUT PINS:** Unconnected CMOS device inputs can be cause of malfunction. If an input pin is unconnected, it is possible that an internal input level may be generated due to noise, etc., causing malfunction. CMOS devices behave differently than Bipolar or NMOS devices. Input levels of CMOS devices must be fixed high or low by using pull-up or pull-down circuitry. Each unused pin should be connected to VDD or GND via a resistor if there is a possibility that it will be an output pin. All handling related to unused pins must be judged separately for each device and according to related specifications governing the device.
- (3) **PRECAUTION AGAINST ESD:** A strong electric field, when exposed to a MOS device, can cause destruction of the gate oxide and ultimately degrade the device operation. Steps must be taken to stop generation of static electricity as much as possible, and quickly dissipate it when it has occurred. Environmental control must be adequate. When it is dry, a humidifier should be used. It is recommended to avoid using insulators that easily build up static electricity. Semiconductor devices must be stored and transported in an anti-static container, static shielding bag or conductive material. All test and measurement tools including work benches and floors should be grounded. The operator should be grounded using a wrist strap. Semiconductor devices must not be touched with bare hands. Similar precautions need to be taken for PW boards with mounted semiconductor devices.
- (4) **STATUS BEFORE INITIALIZATION:** Power-on does not necessarily define the initial status of a MOS device. Immediately after the power source is turned ON, devices with reset functions have not yet been initialized. Hence, power-on does not guarantee output pin levels, I/O settings or contents of registers. A device is not initialized until the reset signal is received. A reset operation must be executed immediately after power-on for devices with reset functions.
- (5) **POWER ON/OFF SEQUENCE:** In the case of a device that uses different power supplies for the internal operation and external interface, as a rule, switch on the external power supply after switching on the internal power supply. When switching the power supply off, as a rule, switch off the external power supply and then the internal power supply. Use of the reverse power on/off sequences may result in the application of an overvoltage to the internal elements of the device, causing malfunction and degradation of internal elements due to the passage of an abnormal current. The correct power on/off sequence must be judged separately for each device and according to related specifications governing the device.
- (6) **INPUT OF SIGNAL DURING POWER OFF STATE :** Do not input signals or an I/O pull-up power supply while the device is not powered. The current injection that results from input of such a signal or I/O pull-up power supply may cause malfunction and the abnormal current that passes in the device at this time may cause degradation of internal elements. Input of signals during the power off state must be judged separately for each device and according to related specifications governing the device.

General Precautions in the Handling of Microprocessing Unit and Microcontroller Unit Products

The following usage notes are applicable to all Microprocessing unit and Microcontroller unit products from Renesas. For detailed usage notes on the products covered by this document, refer to the relevant sections of the document as well as any technical updates that have been issued for the products.

1. Handling of Unused Pins

Handle unused pins in accordance with the directions given under Handling of Unused Pins in the manual.

¾ The input pins of CMOS products are generally in the high-impedance state. In operation with an unused pin in the open-circuit state, extra electromagnetic noise is induced in the vicinity of LSI, an associated shoot-through current flows internally, and malfunctions occur due to the false recognition of the pin state as an input signal become possible. Unused pins should be handled as described under Handling of Unused Pins in the manual.

2. Processing at Power-on

The state of the product is undefined at the moment when power is supplied.

¾ The states of internal circuits in the LSI are indeterminate and the states of register settings and pins are undefined at the moment when power is supplied.
In a finished product where the reset signal is applied to the external reset pin, the states of pins are not guaranteed from the moment when power is supplied until the reset process is completed. In a similar way, the states of pins in a product that is reset by an on-chip power-on reset function are not guaranteed from the moment when power is supplied until the power reaches the level at which resetting has been specified.

3. Prohibition of Access to Reserved Addresses

Access to reserved addresses is prohibited.

¾ The reserved addresses are provided for the possible future expansion of functions. Do not access these addresses; the correct operation of LSI is not guaranteed if they are accessed.

4. Clock Signals

After applying a reset, only release the reset line after the operating clock signal has become stable. When switching the clock signal during program execution, wait until the target clock signal has stabilized.

¾ When the clock signal is generated with an external resonator (or from an external oscillator) during a reset, ensure that the reset line is only released after full stabilization of the clock signal. Moreover, when switching to a clock signal produced with an external resonator (or by an external oscillator) while program execution is in progress, wait until the target clock signal is stable.

5. Differences between Products

Before changing from one product to another, i.e. to a product with a different part number, confirm that the change will not lead to problems.

¾ The characteristics of Microprocessing unit or Microcontroller unit products in the same group but having a different part number may differ in terms of the internal memory capacity, layout pattern, and other factors, which can affect the ranges of electrical characteristics, such as characteristic values, operating margins, immunity to noise, and amount of radiated noise. When changing to a product with a different part number, implement a system-evaluation test for the given product.

Notice

1. Descriptions of circuits, software and other related information in this document are provided only to illustrate the operation of semiconductor products and application examples. You are fully responsible for the incorporation of these circuits, software, and information in the design of your equipment. Renesas Electronics assumes no responsibility for any losses incurred by you or third parties arising from the use of these circuits, software, or information.
2. Renesas Electronics has used reasonable care in preparing the information included in this document, but Renesas Electronics does not warrant that such information is error free. Renesas Electronics assumes no liability whatsoever for any damages incurred by you resulting from errors in or omissions from the information included herein.
3. Renesas Electronics does not assume any liability for infringement of patents, copyrights, or other intellectual property rights of third parties by or arising from the use of Renesas Electronics products or technical information described in this document. No license, express, implied or otherwise, is granted hereby under any patents, copyrights or other intellectual property rights of Renesas Electronics or others.
4. You should not alter, modify, copy, or otherwise misappropriate any Renesas Electronics product, whether in whole or in part. Renesas Electronics assumes no responsibility for any losses incurred by you or third parties arising from such alteration, modification, copy or otherwise misappropriation of Renesas Electronics product.
5. Renesas Electronics products are classified according to the following two quality grades: "Standard" and "High Quality". The recommended applications for each Renesas Electronics product depends on the product's quality grade, as indicated below.
"Standard": Computers; office equipment; communications equipment; test and measurement equipment; audio and visual equipment; home electronic appliances; machine tools; personal electronic equipment; and industrial robots etc.
"High Quality": Transportation equipment (automobiles, trains, ships, etc.); traffic control systems; anti-disaster systems; anti-crime systems; and safety equipment etc.
Renesas Electronics products are neither intended nor authorized for use in products or systems that may pose a direct threat to human life or bodily injury (artificial life support devices or systems, surgical implantations etc.), or may cause serious property damages (nuclear reactor control systems, military equipment etc.). You must check the quality grade of each Renesas Electronics product before using it in a particular application. You may not use any Renesas Electronics product for any application for which it is not intended. Renesas Electronics shall not be in any way liable for any damages or losses incurred by you or third parties arising from the use of any Renesas Electronics product for which the product is not intended by Renesas Electronics.
6. You should use the Renesas Electronics products described in this document within the range specified by Renesas Electronics, especially with respect to the maximum rating, operating supply voltage range, movement power voltage range, heat radiation characteristics, installation and other product characteristics. Renesas Electronics shall have no liability for malfunctions or damages arising out of the use of Renesas Electronics products beyond such specified ranges.
7. Although Renesas Electronics endeavors to improve the quality and reliability of its products, semiconductor products have specific characteristics such as the occurrence of failure at a certain rate and malfunctions under certain use conditions. Further, Renesas Electronics products are not subject to radiation resistance design. Please be sure to implement safety measures to guard them against the possibility of physical injury, and injury or damage caused by fire in the event of the failure of a Renesas Electronics product, such as safety design for hardware and software including but not limited to redundancy, fire control and malfunction prevention, appropriate treatment for aging degradation or any other appropriate measures. Because the evaluation of microcomputer software alone is very difficult, please evaluate the safety of the final products or systems manufactured by you.
8. Please contact a Renesas Electronics sales office for details as to environmental matters such as the environmental compatibility of each Renesas Electronics product. Please use Renesas Electronics products in compliance with all applicable laws and regulations that regulate the inclusion or use of controlled substances, including without limitation, the EU RoHS Directive. Renesas Electronics assumes no liability for damages or losses occurring as a result of your noncompliance with applicable laws and regulations.
9. Renesas Electronics products and technology may not be used for or incorporated into any products or systems whose manufacture, use, or sale is prohibited under any applicable domestic or foreign laws or regulations. You should not use Renesas Electronics products or technology described in this document for any purpose relating to military applications or use by the military, including but not limited to the development of weapons of mass destruction. When exporting the Renesas Electronics products or technology described in this document, you should comply with the applicable export control laws and regulations and follow the procedures required by such laws and regulations.
10. It is the responsibility of the buyer or distributor of Renesas Electronics products, who distributes, disposes of, or otherwise places the product with a third party, to notify such third party in advance of the contents and conditions set forth in this document, Renesas Electronics assumes no responsibility for any losses incurred by you or third parties as a result of unauthorized use of Renesas Electronics products.
11. This document may not be reproduced or duplicated in any form, in whole or in part, without prior written consent of Renesas Electronics.
12. Please contact a Renesas Electronics sales office if you have any questions regarding the information contained in this document or Renesas Electronics products, or if you have any other inquiries.

(Note 1) "Renesas Electronics" as used in this document means Renesas Electronics Corporation and also includes its majority-owned subsidiaries.

(Note 2) "Renesas Electronics product(s)" means any product developed or manufactured by or for Renesas Electronics.



SALES OFFICES

Renesas Electronics Corporation

<http://www.renesas.com>

Refer to "<http://www.renesas.com/>" for the latest and detailed information.

Renesas Electronics America Inc.

2801 Scott Boulevard Santa Clara, CA 95050-2549, U.S.A.
Tel: +1-408-588-6000, Fax: +1-408-588-6130

Renesas Electronics Canada Limited

9251 Yonge Street, Suite 8309 Richmond Hill, Ontario Canada L4C 9T3
Tel: +1-905-237-2004

Renesas Electronics Europe Limited

Dukes Meadow, Millboard Road, Bourne End, Buckinghamshire, SL8 5FH, U.K
Tel: +44-1628-585-100, Fax: +44-1628-585-900

Renesas Electronics Europe GmbH

Arcadiastrasse 10, 40472 Düsseldorf, Germany
Tel: +49-211-6503-0, Fax: +49-211-6503-1327

Renesas Electronics (China) Co., Ltd.

Room 1709, Quantum Plaza, No.27 ZhiChunLu Haidian District, Beijing 100191, P.R.China
Tel: +86-10-8235-1155, Fax: +86-10-8235-7679

Renesas Electronics (Shanghai) Co., Ltd.

Unit 301, Tower A, Central Towers, 555 Langao Road, Putuo District, Shanghai, P. R. China 200333
Tel: +86-21-2226-0888, Fax: +86-21-2226-0999

Renesas Electronics Hong Kong Limited

Unit 1601-1611, 16/F., Tower 2, Grand Century Place, 193 Prince Edward Road West, Mongkok, Kowloon, Hong Kong
Tel: +852-2265-6688, Fax: +852 2886-9022

Renesas Electronics Taiwan Co., Ltd.

13F, No. 363, Fu Shing North Road, Taipei 10543, Taiwan
Tel: +886-2-8175-9600, Fax: +886 2-8175-9670

Renesas Electronics Singapore Pte. Ltd.

80 Bendemeer Road, Unit #06-02 Hyflux Innovation Centre, Singapore 339949
Tel: +65-6213-0200, Fax: +65-6213-0300

Renesas Electronics Malaysia Sdn.Bhd.

Unit 1207, Block B, Menara Amcorp, Amcorp Trade Centre, No. 18, Jln Persiaran Barat, 46050 Petaling Jaya, Selangor Darul Ehsan, Malaysia
Tel: +60-3-7955-9390, Fax: +60-3-7955-9510

Renesas Electronics India Pvt. Ltd.

No.77C, 100 Feet Road, HAL II Stage, Indiranagar, Bangalore, India
Tel: +91-80-67208700, Fax: +91-80-67208777

Renesas Electronics Korea Co., Ltd.

12F., 234 Teheran-ro, Gangnam-Gu, Seoul, 135-080, Korea
Tel: +82-2-558-3737, Fax: +82-2-558-5141