

TABLE 1

No. OF POS	"A"	"B"	"C"
-10	4.25 [0.167]	3.600 [0.1417]	5.40 [0.213]
*-15	6.25 [0.246]	5.600 [0.2205]	7.40 [0.291]
-20	8.25 [0.325]	7.600 [0.2992]	9.40 [0.370]
-30	12.25 [0.482]	11.600 [0.4567]	13.40 [0.528]
-40	16.25 [0.640]	15.600 [0.6142]	17.40 [0.685]
-50	20.25 [0.797]	19.600 [0.7717]	21.40 [0.843]

\* = NOT TOOLED FOR LEAD STYLE 2.50

DO NOT SCALE FROM THIS PRINT

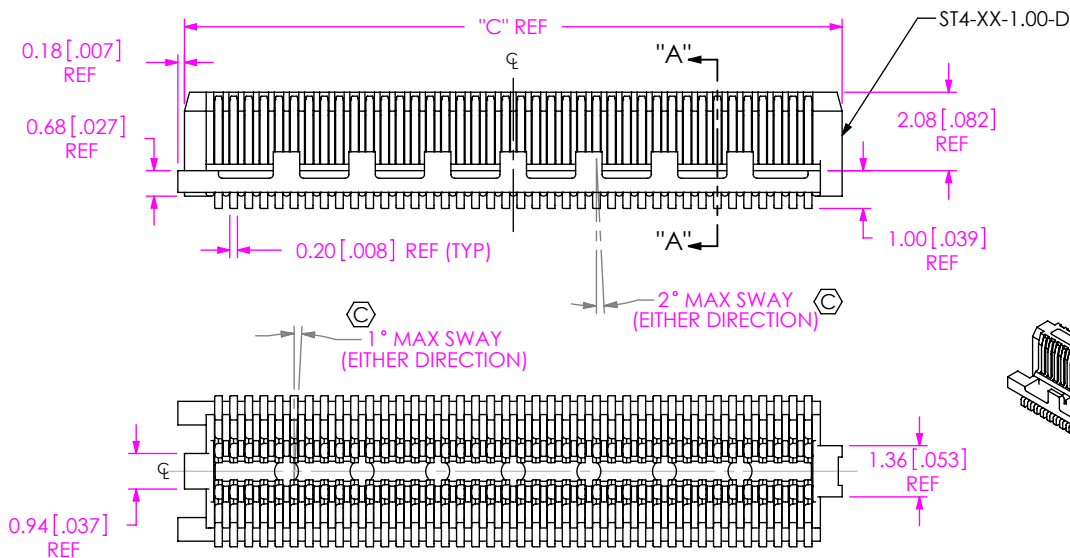
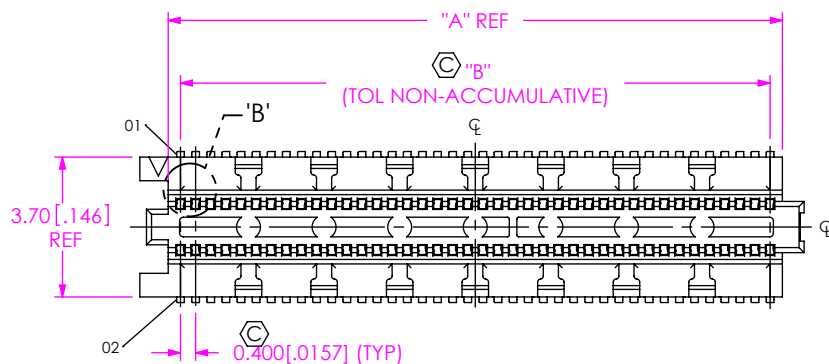


FIG 1

ST4-40-1.00-X-D SHOWN

DESIGNED & DIMENSIONED IN MILLIMETERS(INCHES)

ST4-XX-X.XX-X-D-X-XX-TR

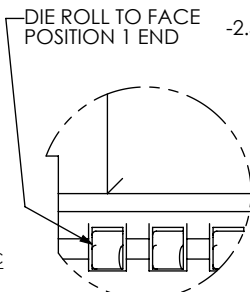
No OF POSITIONS  
-10, \*-15, -20, -30, -40, -50 (PER ROW)

LEAD STYLE

-1.00: SEE FIG 1 (USE T-1M50-1.00-X)  
-1.50: SEE FIG 2, SHT 2 (USE T-1M50-1.50-X)  
-2.50: SEE FIG 3, SHT 2 (USE T-1M50-2.50-X)

PLATING SPECIFICATION

-L: 10µ" SELECTIVE GOLD IN CONTACT AREA, MATTE TIN ON TAIL (USE T-1M50-X.XX-L)



DETAIL 'B' SCALE 20:1

\* = NOT TOOLED FOR LEAD STYLE 2.50  
\*\* = AVAILABLE FOR EXISTING CUSTOMERS ONLY

PACKAGING  
-TR: TAPE AND REEL (SEE NOTES 3 & 4)

PLACEMENT PAD  
-P: PICK AND PLACE PAD (-10, -20, -30, -40, -50 USE PPP-65-01, -15 USE PPP-65-02) (SEE FIG 7 & 8, SHT 3)  
\*\*-PA: PICK AND PLACE PAD WITH -A PINS (USE PPP-70) (SEE FIG 9 & 10, SHT 4) (NOT AVAILABLE ON -15 POS)

OPTIONS

\*\*L: LATCHING (USE WT-39-X.XX-T) (LEAVE BLANK FOR NO OPTION) (TOOLED FOR LEAD STYLE 1.00 ONLY)

ROW SPECIFICATION

-D: DOUBLE

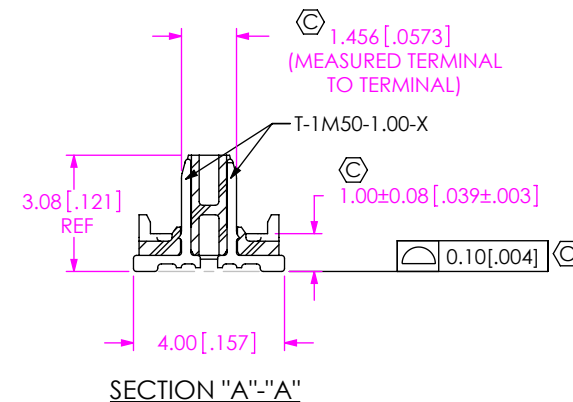


TABLE 2 REF		
STACK HEIGHT		
ST4 LEAD STYLE	SS4 LEAD STYLE	
	-3.00	-3.50
-1.00	4.0 [0.16]	4.5 [0.18]
-1.50	4.5 [0.18]	5.0 [0.20]
-2.50	5.5 [0.22]	6.0 [0.24]

NOTES:

- ⊕ REPRESENTS A CRITICAL DIMENSION.
- MINIMUM PUSHOUT FORCE: SIGNAL: 0.80N [.25 LB], LATCH: 2.22N [.5 LB]
- P OPTION MUST BE SPECIFIED FOR TAPE & REEL PACKAGING.
- FOR QUANTITIES UP TO 49 PIECES, NO LEADER, TRAILER, OR REEL WILL BE SUPPLIED. FOR QUANTITIES OF 50-124 PIECES, NO LEADER OR TRAILER WILL BE SUPPLIED.
- L OPTION NOT INTENDED FOR FOR ALIGNMENT TO PCB. AUTOMATED PLACEMENT RECOMMENDED.

UNLESS OTHERWISE SPECIFIED, DIMENSIONS ARE IN MILLIMETERS.  
TOLERANCES ARE:  
DECIMALS ANGLES  
.X: ±0.3 [.01] 2°  
.XX: ±0.13 [.005]  
.XXX: ±0.051 [.0020]

PROPRIETARY NOTE  
THIS DOCUMENT CONTAINS CONFIDENTIAL AND PROPRIETARY INFORMATION AND ALL DESIGN, MANUFACTURING, REPRODUCTION, USE, PATENT RIGHTS AND SALES RIGHTS ARE EXPRESSLY RESERVED BY SAMTEC, INC. THIS DOCUMENT SHALL NOT BE DISCLOSED, IN WHOLE OR PART, TO ANY UNAUTHORIZED PERSON OR ENTITY NOR REPRODUCED, TRANSFERRED OR INCORPORATED IN ANY OTHER PROJECT IN ANY MANNER WITHOUT THE EXPRESS WRITTEN CONSENT OF SAMTEC, INC.

MATERIAL: DO NOT SCALE DRAWING SHEET SCALE: 5:1  
INSULATOR: LCP, UL 94 V0, COLOR: BLACK  
TERMINAL: PHOS BRONZE



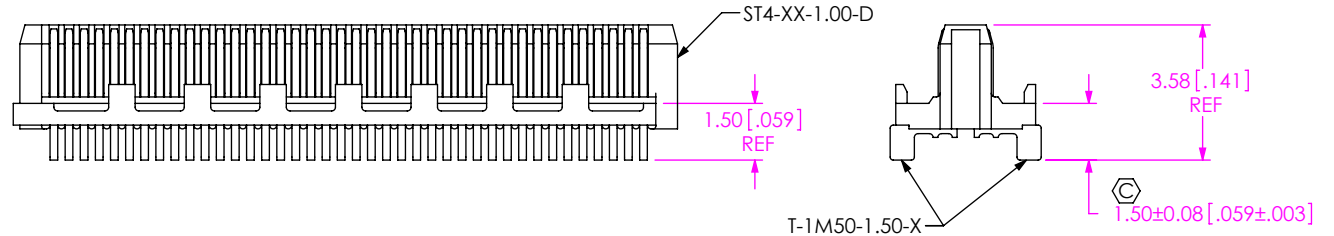
520 PARK EAST BLVD, NEW ALBANY, IN 47150  
PHONE: 812-944-6733 FAX: 812-948-5047  
e-Mail info@SAMTEC.com code 55322

DESCRIPTION:  
0.4mm [.016] TERMINAL STRIP ASSEMBLY

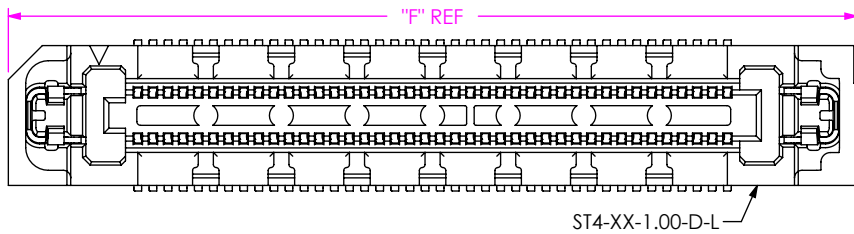
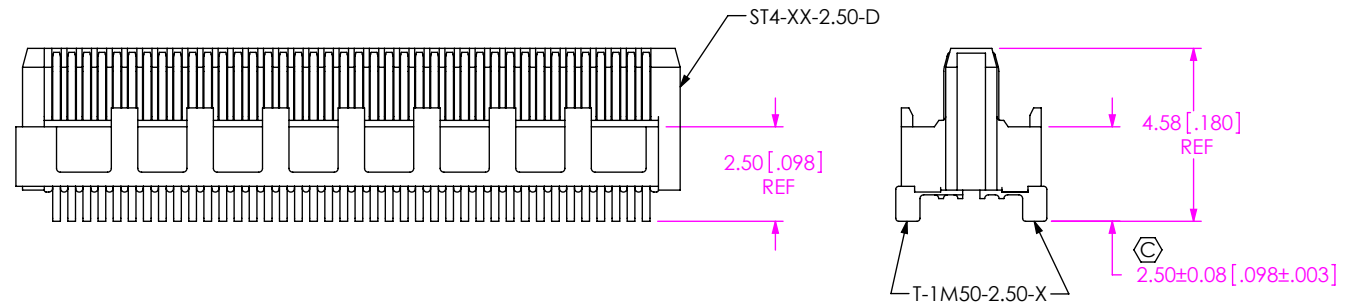
DWG. NO.  
ST4-XX-X.XX-X-D-X-XX-TR

BY: BRATCHER 3/21/2007 SHEET 1 OF 4

**FIG 2**  
1.50 LEAD STYLE  
ST4-40-1.50-X-D SHOWN  
(DIFFERENT AS SHOWN, OTHERWISE SAME AS FIG 1)

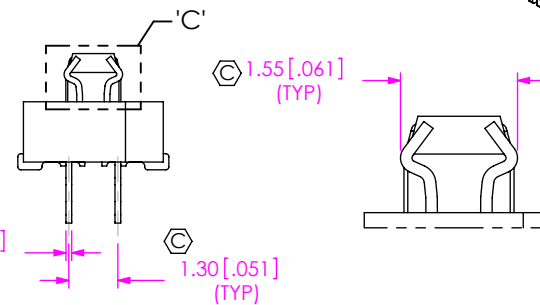
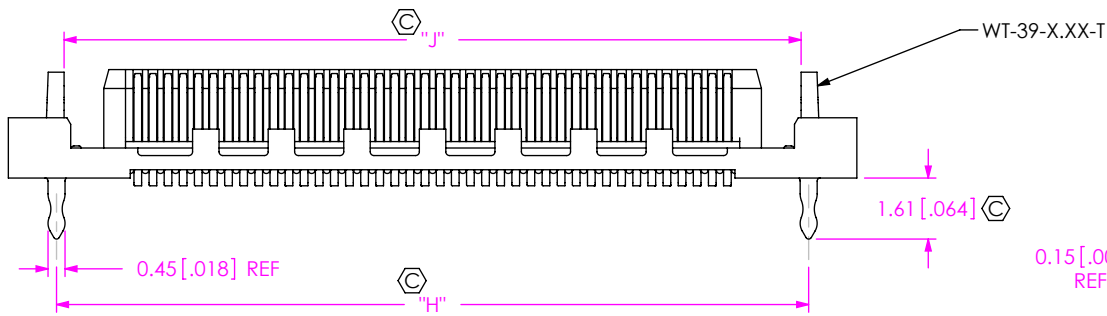
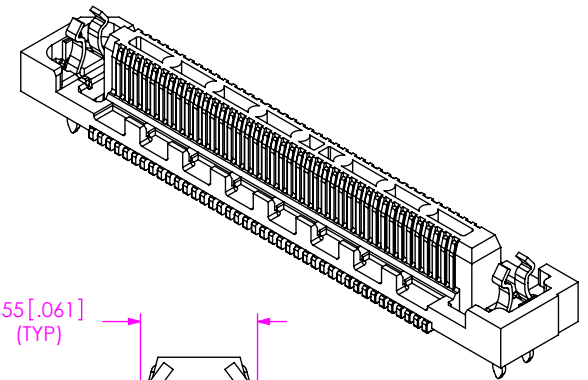


**FIG 3**  
2.50 LEAD STYLE  
ST4-40-2.50-X-D SHOWN  
(DIFFERENT AS SHOWN, OTHERWISE SAME AS FIG 1)



LEAD STYLE	LATCH
-1.00	WT-39-1.00-T
-1.50	WT-39-1.50-T
-2.50	WT-39-2.50-T

TOOLED FOR -1.00 LEAD STYLE ONLY



No. OF POS	"F"	"H"	"J"
-10	10.46 [0.412]	7.90 [0.311]	7.50 [0.295]
-15	12.46 [0.491]	9.90 [0.390]	9.50 [0.374]
-20	14.46 [0.569]	11.90 [0.469]	11.50 [0.453]
-30	18.46 [0.727]	15.90 [0.626]	15.50 [0.610]
-40	22.46 [0.884]	19.90 [0.783]	19.50 [0.768]
-50	26.46 [1.042]	23.90 [0.941]	23.50 [0.925]

**FIG 5**  
\*\*-L: LATCHING OPTION  
ST4-40-1.00-X-D-L SHOWN  
(DIFFERENT AS SHOWN, OTHERWISE SAME AS FIG 1)  
\*\* = AVAILABLE FOR EXISTING CUSTOMERS ONLY

**PROPRIETARY NOTE**  
THIS DOCUMENT CONTAINS CONFIDENTIAL AND PROPRIETARY INFORMATION AND ALL DESIGN, MANUFACTURING, REPRODUCTION, USE, PATENT RIGHTS AND SALES RIGHTS ARE EXPRESSLY RESERVED BY SAMTEC, INC. THIS DOCUMENT SHALL NOT BE DISCLOSED, IN WHOLE OR PART, TO ANY UNAUTHORIZED PERSON OR ENTITY NOR REPRODUCED, TRANSFERRED OR INCORPORATED IN ANY OTHER PROJECT IN ANY MANNER WITHOUT THE EXPRESS WRITTEN CONSENT OF SAMTEC, INC.

DO NOT SCALE DRAWING  
SHEET SCALE: 5:1

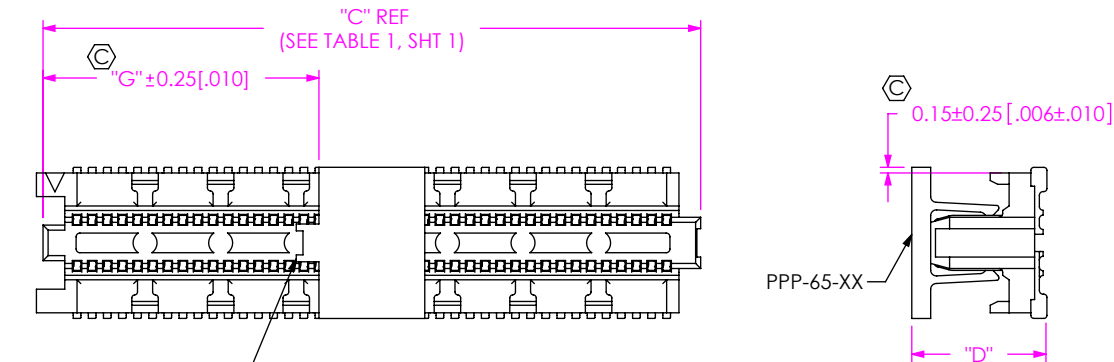


520 PARK EAST BLVD, NEW ALBANY, IN 47150  
PHONE: 812-944-6733 FAX: 812-948-5047  
e-Mail info@SAMTEC.com code 55322

DESCRIPTION:  
0.4mm [.016] TERMINAL STRIP ASSEMBLY

DWG. NO.  
**ST4-XX-X.XX-X-D-X-XX-TR**

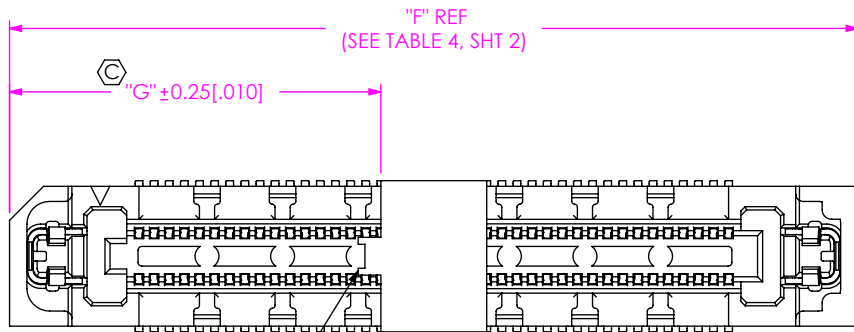
BY: BRATCHER 3/21/2007 SHEET 2 OF 4



NOTCH OF PPP-65-XX TO FACE POS 1 END

**FIG 7**  
 -P: PICK AND PLACE PAD OPTION  
 ST4-40-1.00-X-D-P SHOWN  
 (DIFFERENT AS SHOWN, OTHERWISE SAME AS FIG 1)

LEAD STYLE	"D"
-1.00	3.55 [0.140]
-1.50	4.05 [0.159]
-2.50	5.05 [0.199]



NOTCH OF PPP-65-XX TO FACE POS 1 END

**FIG 8**  
 -P: PICK AND PLACE PAD (W/ LATCH OPTION)  
 ST4-40-1.00-X-D-L-P SHOWN  
 (DIFFERENT AS SHOWN, OTHERWISE SAME AS FIG 1)

No. OF POS	"G" WITH NO - L OPTION	"G" WITH - L OPTION
-10	1.30 [0.051]	3.83 [0.151]
*-15	2.30 [0.091]	4.83 [0.190]
-20	3.30 [0.130]	5.83 [0.230]
-30	5.30 [0.209]	7.83 [0.308]
-40	7.30 [0.287]	9.83 [0.387]
-50	9.30 [0.366]	11.83 [0.466]

\* = NOT TOOLED FOR LEAD STYLE 2.50

**PROPRIETARY NOTE**  
 THIS DOCUMENT CONTAINS CONFIDENTIAL AND PROPRIETARY INFORMATION AND ALL DESIGN, MANUFACTURING, REPRODUCTION, USE, PATENT RIGHTS AND SALES RIGHTS ARE EXPRESSLY RESERVED BY SAMTEC, INC. THIS DOCUMENT SHALL NOT BE DISCLOSED, IN WHOLE OR PART, TO ANY UNAUTHORIZED PERSON OR ENTITY NOR REPRODUCED, TRANSFERRED OR INCORPORATED IN ANY OTHER PROJECT IN ANY MANNER WITHOUT THE EXPRESS WRITTEN CONSENT OF SAMTEC, INC.

DO NOT SCALE DRAWING

SHEET SCALE: 5:1

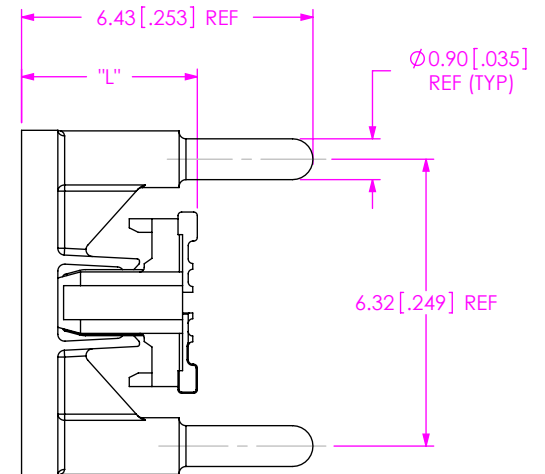
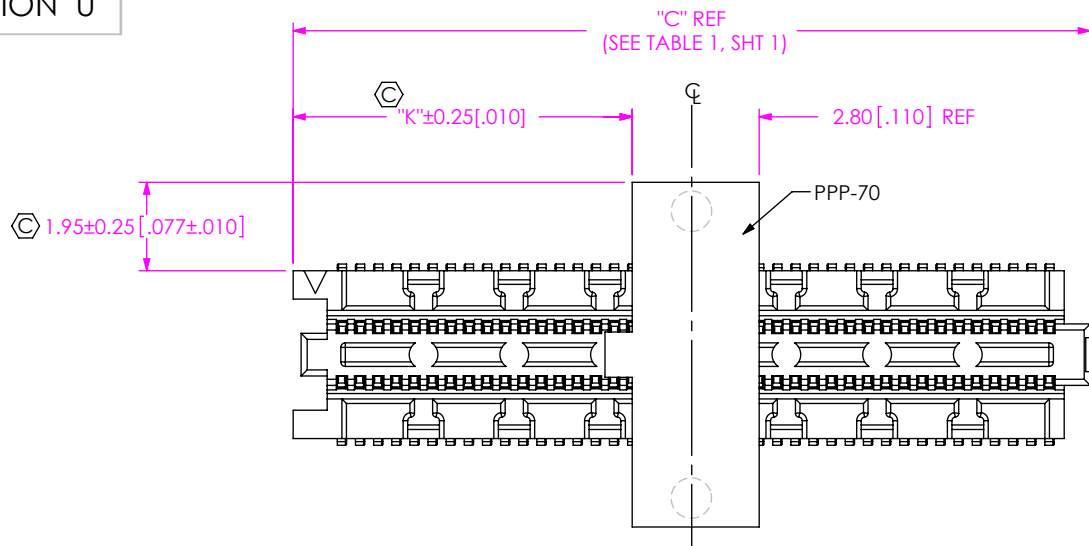


520 PARK EAST BLVD, NEW ALBANY, IN 47150  
 PHONE: 812-944-6733 FAX: 812-948-5047  
 e-Mail info@SAMTEC.com code 55322

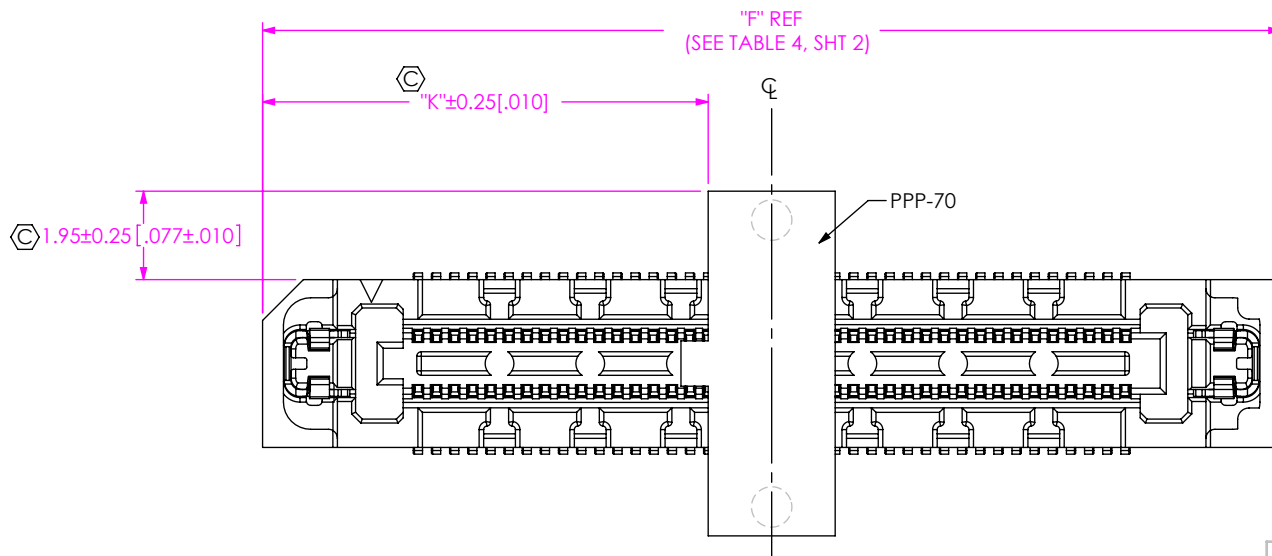
DESCRIPTION:  
 0.4mm[.016] TERMINAL STRIP ASSEMBLY

DWG. NO.  
**ST4-XX-X.XX-X-D-X-XX-TR**

BY: BRATCHER 3/21/2007 SHEET 3 OF 4



**FIG 9**  
 \*\*-PA: PICK & PLACE WITH ALIGNMENT PINS  
 ST4-40-1.00-X-D-PA SHOWN  
 (DIFFERENT AS SHOWN, OTHERWISE SAME AS FIG 1)  
 \*\* = AVAILABLE FOR EXISTING CUSTOMERS ONLY



**FIG 10**  
 \*\*-PA: PICK & PLACE WITH ALIGNMENT PINS ( WITH -L OPTION)  
 ST4-40-1.00-X-D-L-PA SHOWN  
 (DIFFERENT AS SHOWN, OTHERWISE SAME AS FIG 1)  
 \*\* = AVAILABLE FOR EXISTING CUSTOMERS ONLY

**TABLE 9**

POS	"K" W/O -L OPTION	"K" W/ -L OPTION
-10	1.300 [0.051]	3.830 [0.151]
-20	3.300 [0.130]	5.830 [0.230]
-30	5.300 [0.209]	7.830 [0.308]
-40	7.300 [0.287]	9.830 [0.387]
-50	9.300 [0.366]	11.830 [0.466]

**TABLE 10**

LEAD STYLE	"L"
-1.00	3.58 [0.141]
-1.50	4.08 [0.161]
-2.50	5.08 [0.200]

**PROPRIETARY NOTE**  
 THIS DOCUMENT CONTAINS CONFIDENTIAL AND PROPRIETARY INFORMATION AND ALL DESIGN, MANUFACTURING, REPRODUCTION, USE, PATENT RIGHTS AND SALES RIGHTS ARE EXPRESSLY RESERVED BY SAMTEC, INC. THIS DOCUMENT SHALL NOT BE DISCLOSED, IN WHOLE OR PART, TO ANY UNAUTHORIZED PERSON OR ENTITY NOR REPRODUCED, TRANSFERRED OR INCORPORATED IN ANY OTHER PROJECT IN ANY MANNER WITHOUT THE EXPRESS WRITTEN CONSENT OF SAMTEC, INC.

DO NOT SCALE DRAWING

SHEET SCALE: 5:1



520 PARK EAST BLVD, NEW ALBANY, IN 47150  
 PHONE: 812-944-6733 FAX: 812-948-5047  
 e-Mail info@SAMTEC.com code 5322

DESCRIPTION:  
 0.4mm[.016] TERMINAL STRIP ASSEMBLY

DWG. NO.  
 ST4-XX-X.XX-X-D-X-XX-TR

BY: BRATCHER 3/21/2007 SHEET 4 OF 4