

## MOTIONBEE™ family acceleration sensor

### Features

- Ready-to-use IEEE 802.15.4 compliant wireless acceleration sensor
- Integrated three axis MEMS-based linear accelerometer
- Antenna on board
- No external components required excluding power supplier
- Possibility to be programmed via SIF connector with EMZNET ZigBee® protocol stack and custom applications
- Board fixing with screws or pads for SMD soldering
- Reset and commissioning push buttons externally available
- Power connector and power switch externally available
- Two LEDs externally available for connection check and debugging
- Board dimensions: 49 x 27 x 5 mm
- CE / FCC compliant

### Description

SPMB250-A1 board is a ready-to-use wireless acceleration sensor based on an IEEE 802.15.4 compliant radio. It is designed to enable development of applications for remote motion monitoring in wireless sensor networks systems.

The board is based on the ZigBee® module SPZB250 which performs both the RF radio and controlling functions and the three axis linear accelerometer sensor LIS3LV02DL.

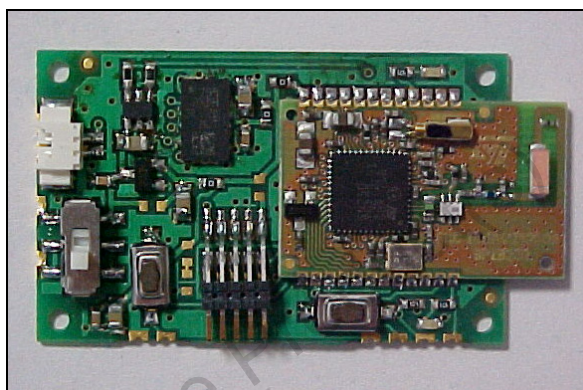

The ZigBee® module contains the SN250 SoC integrating a fully compliant 802.15.4 radio together with a microcontroller that can be used to elaborate sensor data and networking functionalities. SN250 can be programmed to run the EMZNET ZigBee® protocol stack from Ember Corporation. The module is programmable thanks to the SIF connector available on the SPZB250 module.

The LIS3LV02DL three axis accelerometer is a low power low voltage linear accelerometer with digital output that can operate in the user selectable range  $\pm 2 g$  or  $\pm 6 g$  and with programmable data rate.

The controller inside SPZB250 module handles all the networking functions and it can be used to implement custom procedures to elaborate and send data collected by the acceleration sensor.

The board is ready-to-use, requiring only an external power supplier to connect to the integrated standard two pole connector. A switch is present in series to the supply connection to power on / off the board.

# Contents

|           |  |           |
|-----------|--|-----------|
| <b>1</b>  | <b>RoHS compliance</b> .....             | <b>3</b>  |
| <b>2</b>  | <b>Connections - pad out</b> .....       | <b>3</b>  |
| <b>3</b>  | <b>Block diagram</b> .....               | <b>4</b>  |
| <b>4</b>  | <b>Maximum ratings</b> .....             | <b>5</b>  |
|           | 4.1 Absolute maximum ratings .....       | 5         |
|           | 4.2 Operating ranges .....               | 5         |
| <b>5</b>  | <b>Electrical characteristics</b> .....  | <b>6</b>  |
|           | 5.1 DC I/O specification .....           | 6         |
| <b>6</b>  | <b>Board description</b> .....           | <b>7</b>  |
|           | 6.1 Power supply connector (J1) .....    | 7         |
|           | 6.2 ON / OFF switch (SW2) .....          | 7         |
|           | 6.3 SIF connector (J2) .....             | 8         |
|           | 6.4 Pad description .....                | 9         |
|           | 6.5 LED indicators .....                 | 9         |
| <b>7</b>  | <b>Board layout</b> .....                | <b>10</b> |
| <b>8</b>  | <b>Soldering</b> .....                   | <b>11</b> |
| <b>9</b>  | <b>Recommendations</b> .....             | <b>12</b> |
| <b>10</b> | <b>Radiation pattern</b> .....           | <b>13</b> |
| <b>11</b> | <b>Mechanical dimensions</b> .....       | <b>14</b> |
| <b>12</b> | <b>Ordering information scheme</b> ..... | <b>16</b> |
| <b>13</b> | <b>Revision history</b> .....            | <b>17</b> |

# 1 RoHS compliance

ST modules are RoHS compliant and being based on ST devices comply with ECOPACK® norms implemented by ST.

# 2 Connections - pad out

Figure 1. Connections

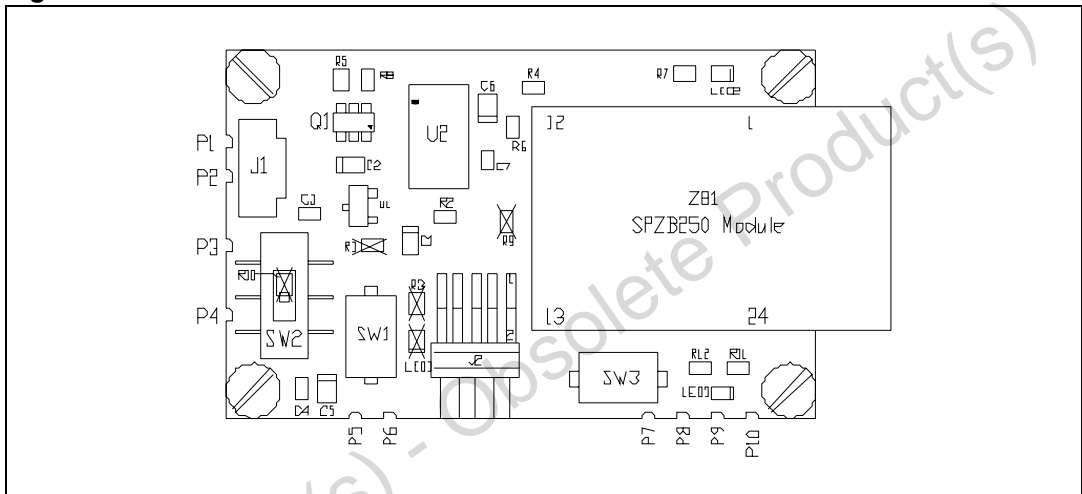

### 3 Block diagram

Figure 2. Block diagram

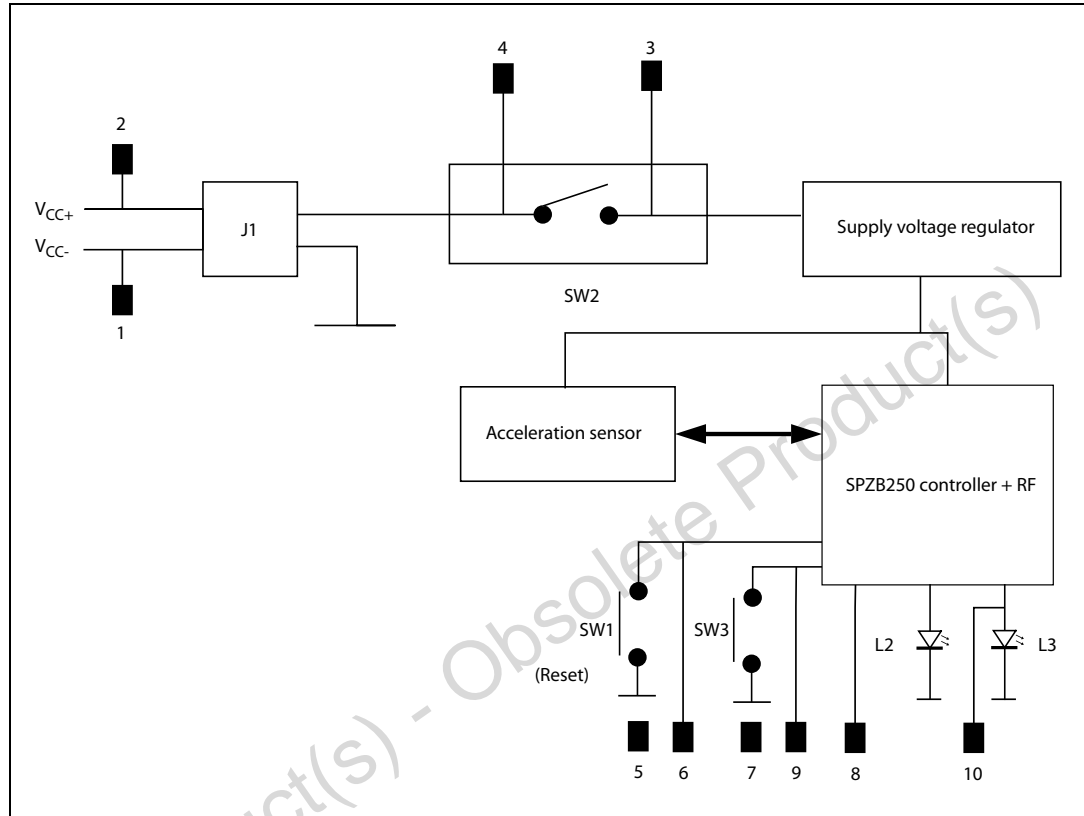

## 4 Maximum ratings

### 4.1 Absolute maximum ratings

Table 1. Absolute maximum ratings

| Symbol             | Parameter                     | Values |     | Unit |
|--------------------|-------------------------------|--------|-----|------|
|                    |                               | Min    | Max |      |
| V <sub>CC</sub>    | Board supply voltage          |        | 7   | V    |
| T <sub>OPmax</sub> | Operating ambient temperature | -40    | +85 | °C   |
| T <sub>STG</sub>   | Storage temperature           | -40    | +85 | °C   |

### 4.2 Operating ranges

Operating ranges define the limits for functional operation and parametric characteristics of the module.

Functionality outside these limits is not implied

Table 2. Operating ranges

| Symbol           | Parameter                        | Conditions                     | Values |     |     | Unit |
|------------------|----------------------------------|--------------------------------|--------|-----|-----|------|
|                  |                                  |                                | Min    | Typ | Max |      |
| V <sub>CC</sub>  | Module supply voltage            | -40 °C < T < 85 °C             | 3.6    |     | 6   | V    |
| T <sub>STG</sub> | Operating ambient temperature    |                                | -40    |     | +85 | °C   |
| I <sub>OP</sub>  | Operation current <sup>(1)</sup> | V <sub>in</sub> = 4 V stand by |        | 16  |     | μA   |
|                  |                                  | V <sub>in</sub> = 4 V TX mode  |        | 37  |     | mA   |
|                  |                                  | V <sub>in</sub> = 4 V RX mode  |        | 36  |     | mA   |
|                  |                                  | V <sub>in</sub> = 4 V CPU only |        | 9   |     | mA   |

1. Values indicated in the table are referred to the single states (Standby TX,RX,...); the overall current depends on the working strategy used by the application

## 5 Electrical characteristics

### 5.1 DC I/O specification

Table 3. DC input / output specification

| Symbol  | Parameter   | Conditions   | Values |      |      | Unit          |
|---------|---|--|--------|------|------|---------------|
|         |   |  | Min    | Typ  | Max  |               |
| VIL     | Low level input voltage<br>SW1 (Reset) and SW3    | Vin = 4 V  |        |      | 0.6  | V             |
| VOL     | Low level output voltage<br>P8 (L1) and P10 (L2)  | Vin = 4 V  |        |      | 0.2  | V             |
| VOH     | High level output voltage<br>P8 (L1) and P10 (L2) | Vin = 4 V  | 2.7    |      | 3.3  | V             |
| IOLed   |   | Vin = 4 V  |        |      | 4    | mA            |
| RFin    | Input frequency range                             |  | 2405   |      | 2480 | MHz           |
| RX sens | Receiver sensitivity                              | @PER 1 %   |        | -92  |      | dBm           |
| RFout   | Output frequency range                            |  | 2405   |      | 2480 | MHz           |
| TXpout  | Nominal output power                              | @ 2402 – 2480 MHz                                    |        | 0    |      | dBm           |
| FS      | Acceleration sensor<br>Measurement Range          |  | ±1.7   | ±2.0 |      | <i>g</i>      |
|         |   |  | ±5.3   | ±6.0 |      | <i>g</i>      |
| Dres    | Acceleration sensor<br>Resolution                 | Full-scale = ±2 <i>g</i><br>Output data rate = 40 Hz |        | 1.0  |      | mg            |
| So      | Acceleration sensor<br>Sensitivity                | Full-scale = ±2 <i>g</i><br>12 bit representation    | 920    | 1024 | 1126 | LSb/ <i>g</i> |
|         |   | Full-scale = ±6 <i>g</i><br>12 bit representation    | 306    | 340  | 374  | LSB/ <i>g</i> |

## 6 Board description

### 6.1 Power supply connector (J1)

When used directly connected to the system to be monitored in terms of vibration / acceleration the only connection needed is the one related to the power source.

To have a standard and in the same time miniaturized connection a two pole connector has been chosen (i.e. Molex 53261-0271 or equivalent)

**Figure 3. J1 connector**

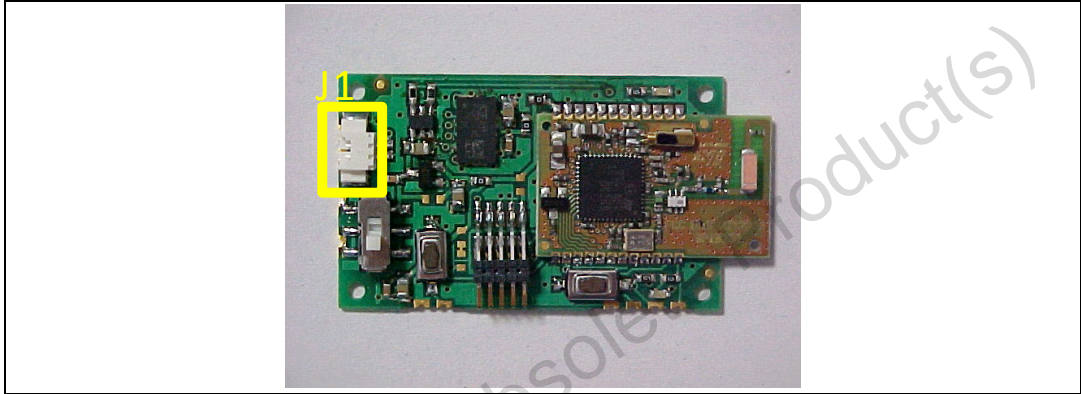

### 6.2 ON / OFF switch (SW2)

To power on / off the board a switch has been provided aboard.

**Figure 4. SW2 switch**

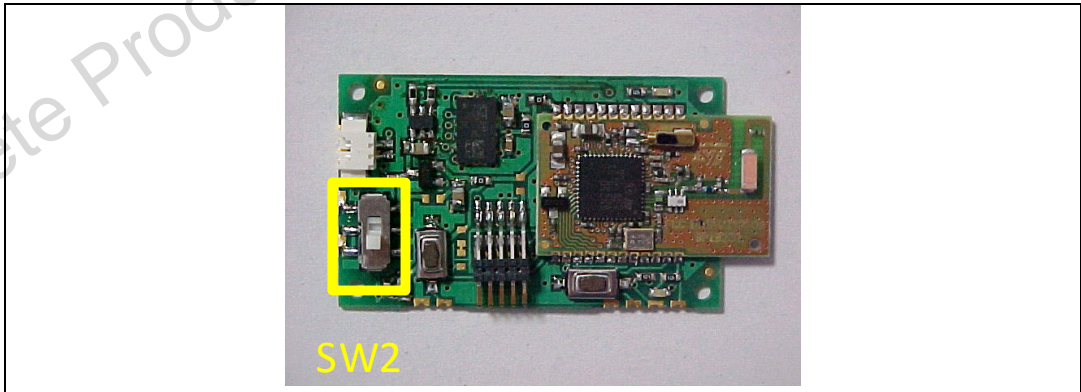

### 6.3 SIF connector (J2)

To allow the user to program the board, a SIF connector is available.

Signals available on this connector are:

**Figure 5. SIF - pin description**

|           |   |    |          |
|-----------|---|----|----------|
| Vdd       | 1 | 2  | SIF_MISO |
| GND       | 3 | 4  | SIF_MOSI |
| GND       | 5 | 6  | SIF_CLK  |
| SIF_LOADB | 7 | 8  | RSTB     |
| PTI_EN    | 9 | 10 | PTI_DATA |

**Figure 6. SIF connector**

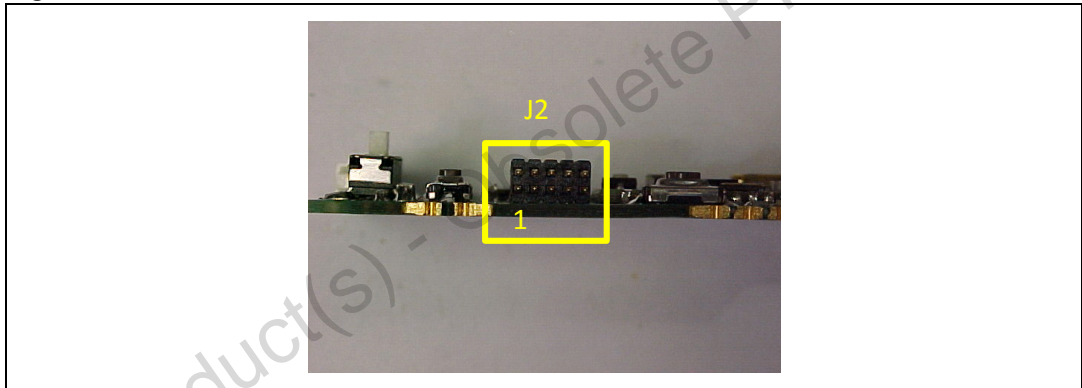



## 6.4 Pad description

When used on a motherboard the boundary pads on the SPMB250-A1 can be used to get the connections with the remaining part of the circuit present on the motherboard itself.

The meaning of the pads is listed in the following table:

**Table 4. Pad description**

| N.  | Pin name           | I/O   | Description   |
|-----|--------------------|-------|---|
| P1  | J1 – Vcc- (GND)    | Power | GND input voltage supply  |
| P2  | J1 – Vcc +         | Power | Positive input voltage supply   |
| P3  | SW2-O              | Power | Power switch pole connected to the circuit  |
| P4  | SW2-I              | Power | Power switch pole connected to Vin +  |
| P5  | GND                | Power |   |
| P6  | SW1 (RESET / RSTB) | I     | Reset push button. Reset occurs when this pad is tied to GND                                  |
| P7  | GND                | Power |   |
| P8  | GPIO8              | I/O   | GPIO8 of SPZB250 module   |
| P9  | SW3                | I     | General purpose push button / commissioning push button. It can used also as I/O pin          |
| P10 | L3 – GPIO13        | O     | Led 3 general purpose (connected to SPZB250 GPIO13) A resistor is needed to limit the current |

## 6.5 LED indicators

Two LED L2 (Led2) and L3 (Led3) are connected to the GPIO of SPZB250 module to be used to monitor the module activity. Driving pin of L3 is also available as pad out (P10).

# 7 Board layout

Figure 7. Board layout

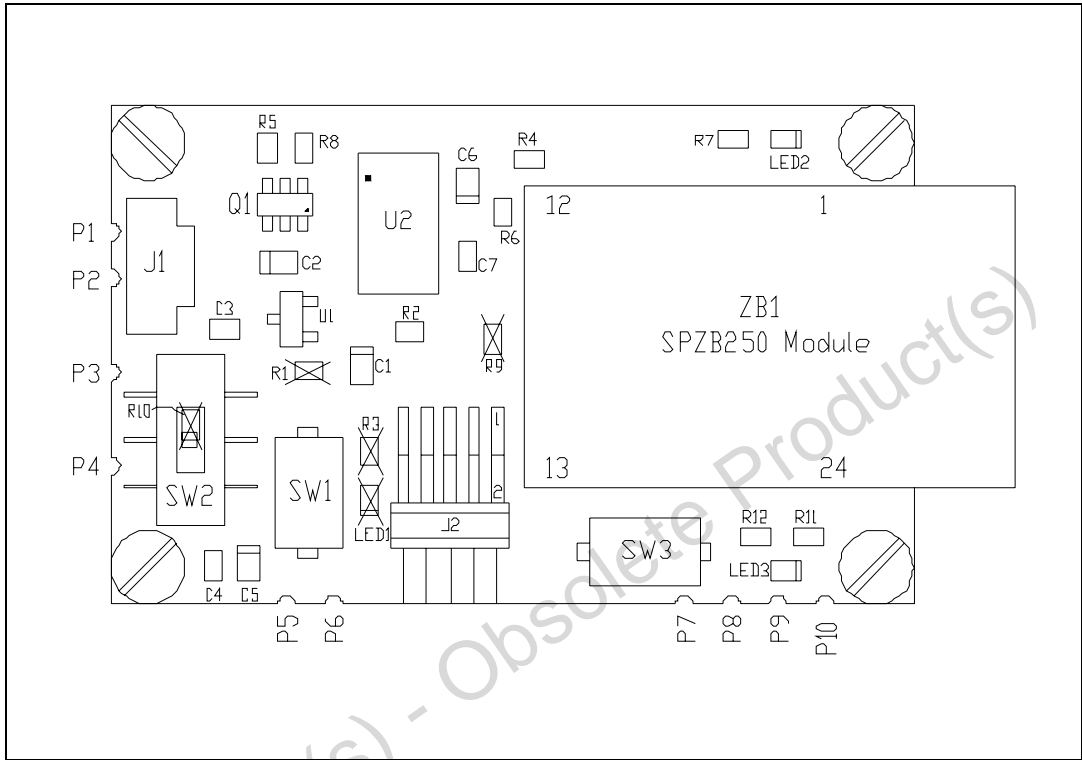

Obsolete Product(s) - Obsolete Product(s)

## 8 Soldering

Soldering phase has to be carefully carried out: in order to avoid undesired melting phenomenon, particular attention has to be paid on the set up of the peak temperature.

Here following some suggestions for the temperature profile based on IPC/JEDEC J-STD-020C, July 2004 recommendations.

**Table 5. Soldering**

| Profile feature                                       | PB free assembly |
|---|------------------|
| Average ramp up rate ( $T_{S_{MAX}}$ to $T_P$ )       | 3 °C / sec max   |
| Preheat   |                  |
| Temperature min ( $T_S$ min)                          | 150 °C           |
| Temperature max ( $T_S$ max)                          | 200 °C           |
| Time ( $t_S$ min to $t_S$ max) ( $t_S$ )              | 60 – 100 sec     |
| Time maintained above:                                |                  |
| Temperature $T_L$                                     | 217 °C           |
| Time $t_L$  | 40 – 70 sec      |
| Peak temperature ( $T_p$ )                            | 240 + 0 °C       |
| Time within 5 °C of actual peak temperature ( $t_p$ ) | 10 – 20 sec      |
| Ramp down rate  | 6 °C / sec       |
| Time from 25 °C to peak temperature                   | 8 minutes max    |

**Figure 8. Soldering**

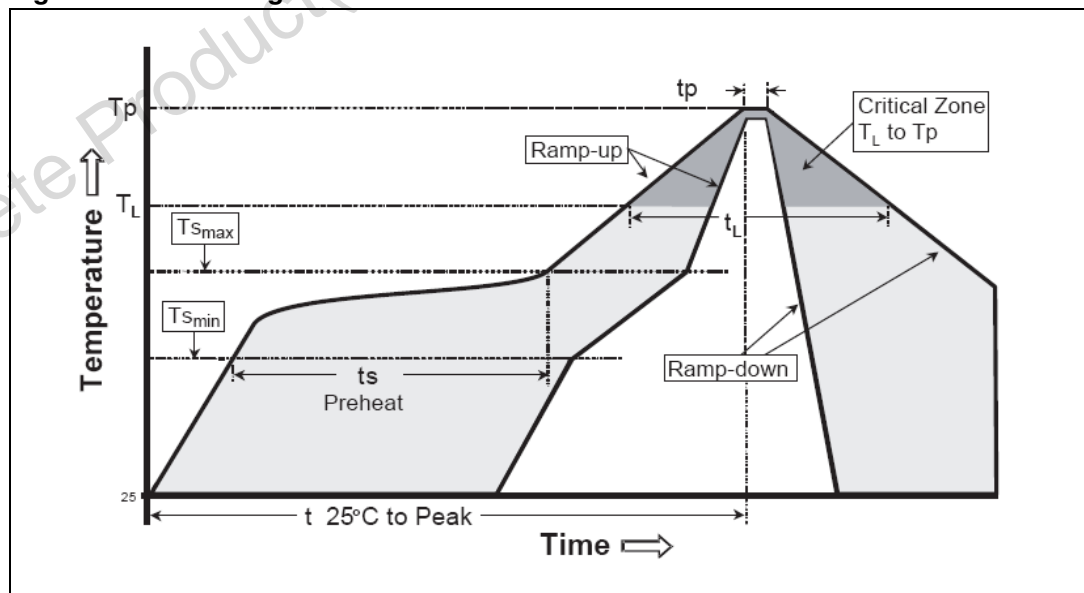

## 9 Recommendations

- An integrated antenna is present on the board:
  - Assembly the board in the application avoiding any shielding of the antenna
  - Avoid metallic parts close to the antenna
  - Do not use metallic case
- Board fixing can be done with 4 screws:
  - In case of fixing on metallic base insert an insulator foil between the board and the base in order to avoid any potential short circuit

Obsolete Product(s) - Obsolete Product(s)

# 10 Radiation pattern

SPMB250-A1 is based on the SPZB250 module which incorporates an RF section with an integrated antenna (Murata ANCV12G44SAA127).

The antenna radiation pattern (as measured on the SPZB250 module) follows.

**Figure 9. Measurement direction**

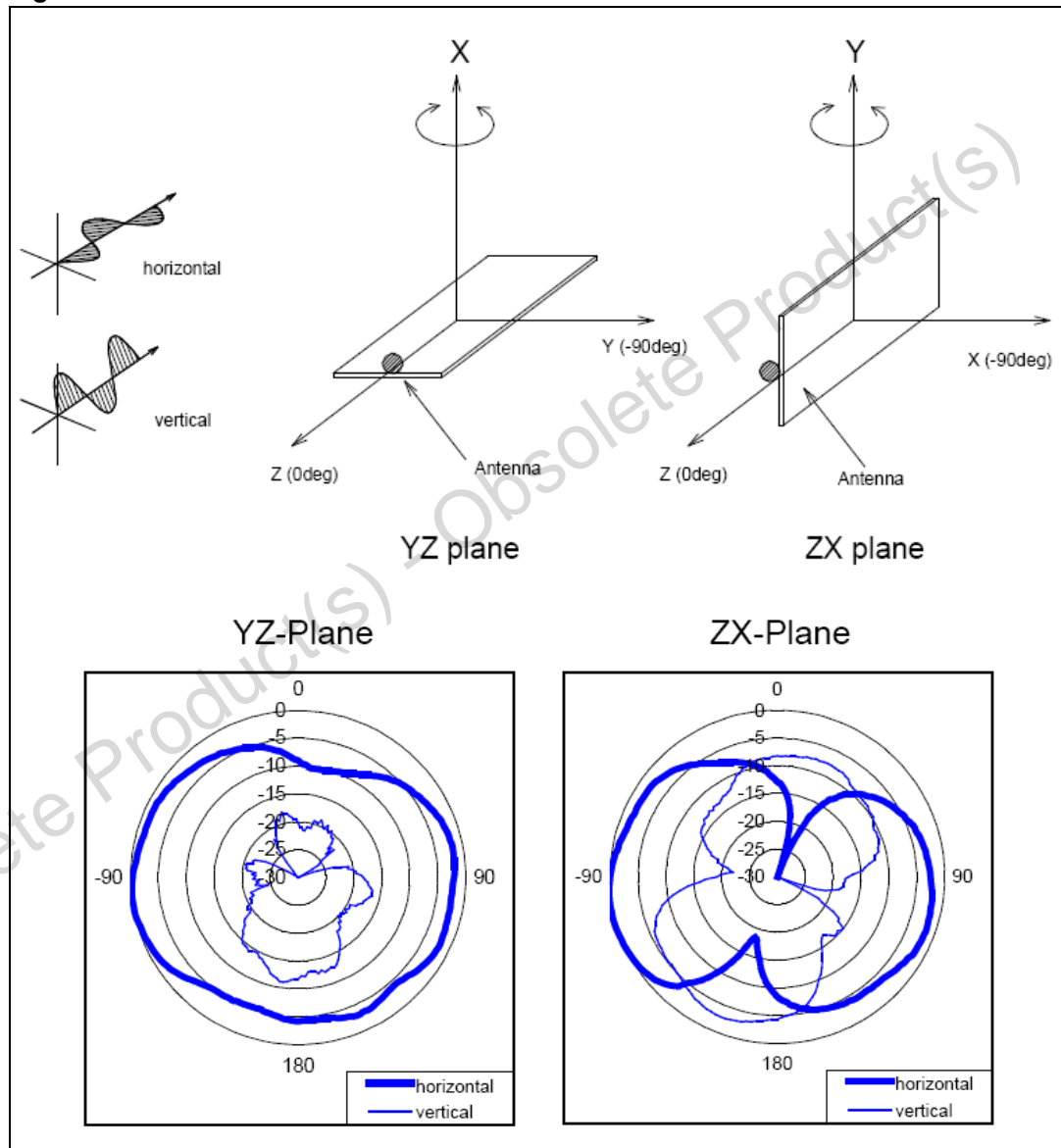

# 11 Mechanical dimensions

In order to meet environmental requirements, ST offers these devices in different grades of ECOPACK® packages, depending on their level of environmental compliance. ECOPACK® specifications, grade definitions and product status are available at: [www.st.com](http://www.st.com). ECOPACK is an ST trademark.

Figure 10. Mechanical dimensions

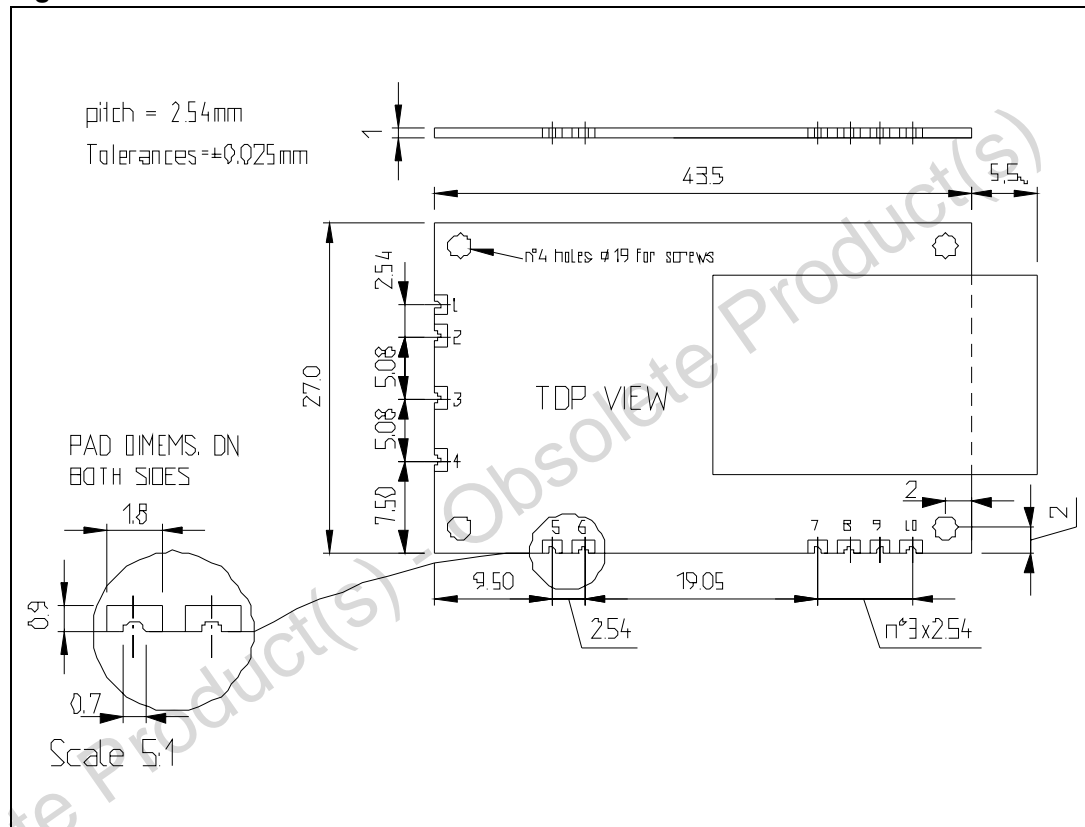
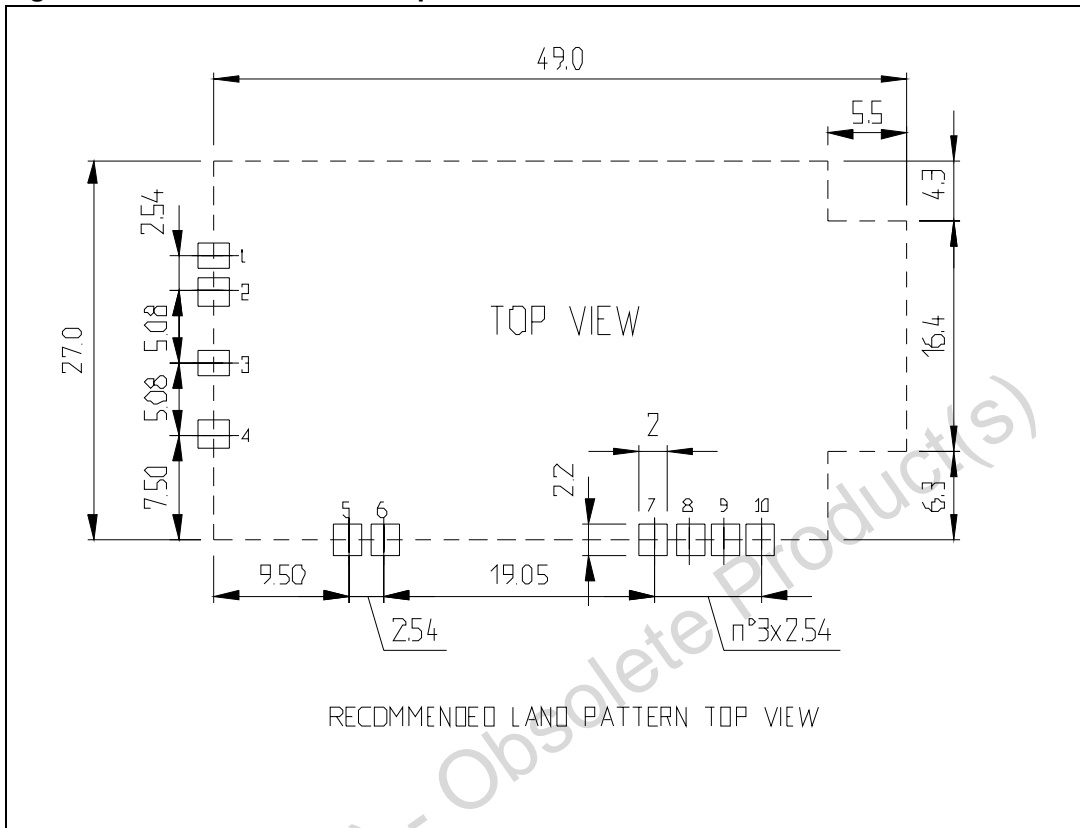

Figure 11. Recommended land pattern



## 12 Ordering information scheme

**Table 6. Ordering information scheme**

|                      | SP | MB | 250 | -A | 1 |
|----------------------|----|----|-----|----|---|
| Subsystem product    |    |    |     |    |   |
| MOTIONBEE™ family    |    |    |     |    |   |
| SN250 -based board   |    |    |     |    |   |
| Accelerometer sensor |    |    |     |    |   |
| Version 1            |    |    |     |    |   |

Obsolete Product(s) - Obsolete Product(s)



## 13 Revision history

Table 7. Document revision history

| Date        | Revision | Changes                                   |
|-------------|----------|---|
| 12-Feb-2009 | 1        | Initial release                           |
| 03-Nov-2009 | 2        | Added <a href="#">Section 1 on page 3</a> |

Obsolete Product(s) - Obsolete Product(s)

**Please Read Carefully:**

Information in this document is provided solely in connection with ST products. STMicroelectronics NV and its subsidiaries ("ST") reserve the right to make changes, corrections, modifications or improvements, to this document, and the products and services described herein at any time, without notice.

All ST products are sold pursuant to ST's terms and conditions of sale.

Purchasers are solely responsible for the choice, selection and use of the ST products and services described herein, and ST assumes no liability whatsoever relating to the choice, selection or use of the ST products and services described herein.

No license, express or implied, by estoppel or otherwise, to any intellectual property rights is granted under this document. If any part of this document refers to any third party products or services it shall not be deemed a license grant by ST for the use of such third party products or services, or any intellectual property contained therein or considered as a warranty covering the use in any manner whatsoever of such third party products or services or any intellectual property contained therein.

**UNLESS OTHERWISE SET FORTH IN ST'S TERMS AND CONDITIONS OF SALE ST DISCLAIMS ANY EXPRESS OR IMPLIED WARRANTY WITH RESPECT TO THE USE AND/OR SALE OF ST PRODUCTS INCLUDING WITHOUT LIMITATION IMPLIED WARRANTIES OF MERCHANTABILITY, FITNESS FOR A PARTICULAR PURPOSE (AND THEIR EQUIVALENTS UNDER THE LAWS OF ANY JURISDICTION), OR INFRINGEMENT OF ANY PATENT, COPYRIGHT OR OTHER INTELLECTUAL PROPERTY RIGHT.**

**UNLESS EXPRESSLY APPROVED IN WRITING BY AN AUTHORIZED ST REPRESENTATIVE, ST PRODUCTS ARE NOT RECOMMENDED, AUTHORIZED OR WARRANTED FOR USE IN MILITARY, AIR CRAFT, SPACE, LIFE SAVING, OR LIFE SUSTAINING APPLICATIONS, NOR IN PRODUCTS OR SYSTEMS WHERE FAILURE OR MALFUNCTION MAY RESULT IN PERSONAL INJURY, DEATH, OR SEVERE PROPERTY OR ENVIRONMENTAL DAMAGE. ST PRODUCTS WHICH ARE NOT SPECIFIED AS "AUTOMOTIVE GRADE" MAY ONLY BE USED IN AUTOMOTIVE APPLICATIONS AT USER'S OWN RISK.**

Resale of ST products with provisions different from the statements and/or technical features set forth in this document shall immediately void any warranty granted by ST for the ST product or service described herein and shall not create or extend in any manner whatsoever, any liability of ST.

ST and the ST logo are trademarks or registered trademarks of ST in various countries.

Information in this document supersedes and replaces all information previously supplied.

The ST logo is a registered trademark of STMicroelectronics. All other names are the property of their respective owners.

© 2009 STMicroelectronics - All rights reserved

STMicroelectronics group of companies

Australia - Belgium - Brazil - Canada - China - Czech Republic - Finland - France - Germany - Hong Kong - India - Israel - Italy - Japan - Malaysia - Malta - Morocco - Philippines - Singapore - Spain - Sweden - Switzerland - United Kingdom - United States of America

[www.st.com](http://www.st.com)