

THIS DRAWING IS UNPUBLISHED. RELEASED FOR PUBLICATION .19  
 BY AMP INCORPORATED. ALL RIGHTS RESERVED.

LOC	DIST	REVISIONS					
		F	LTR	DESCRIPTION	DATE	DWN	APVD
BD	84		O	RLSE PER NPR 142, WAS 98-2198-3	11SEP98	-	-
			A	REVISED PER EC 0G40-0070-99	27APR99	SW	RB

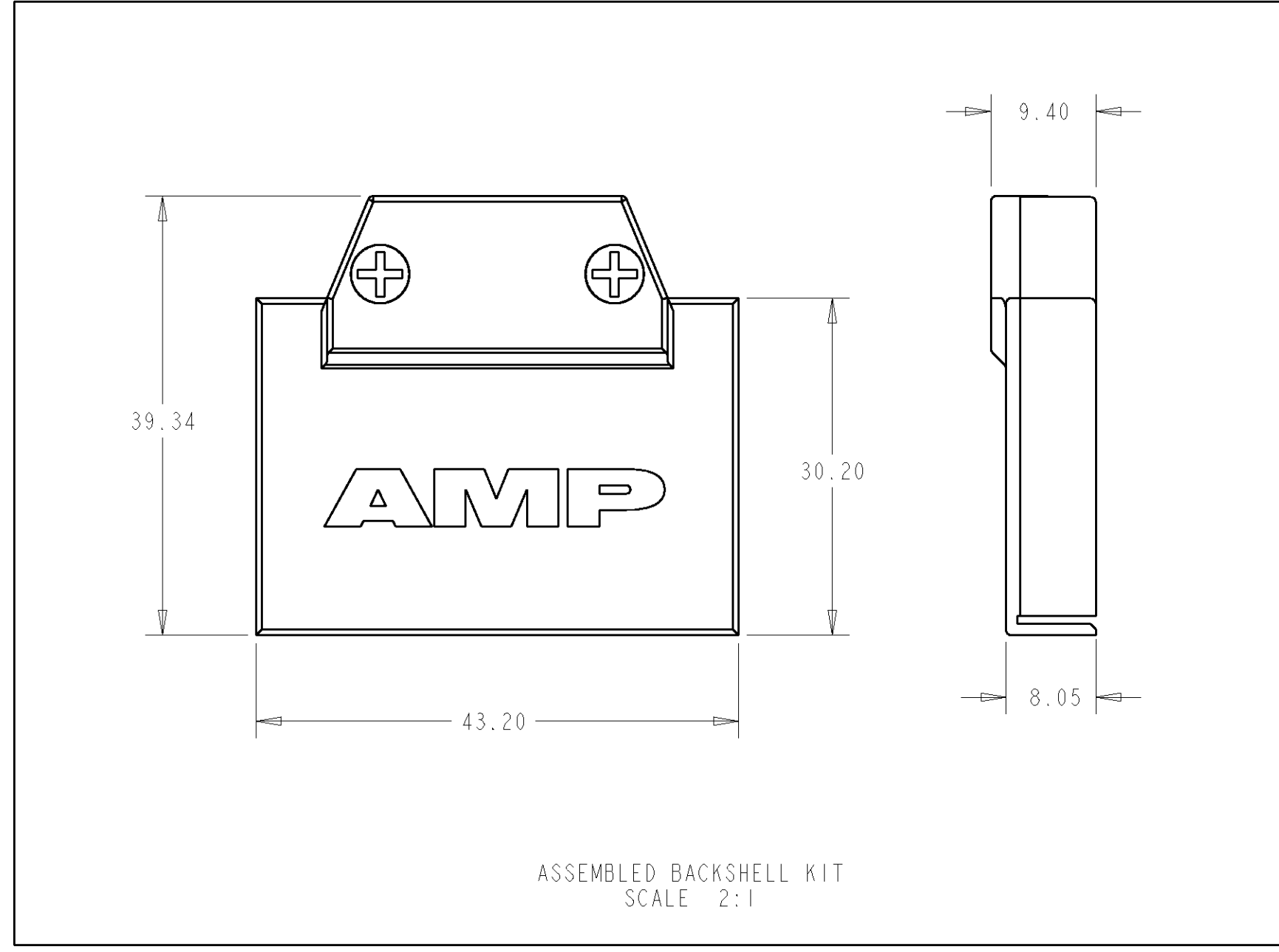
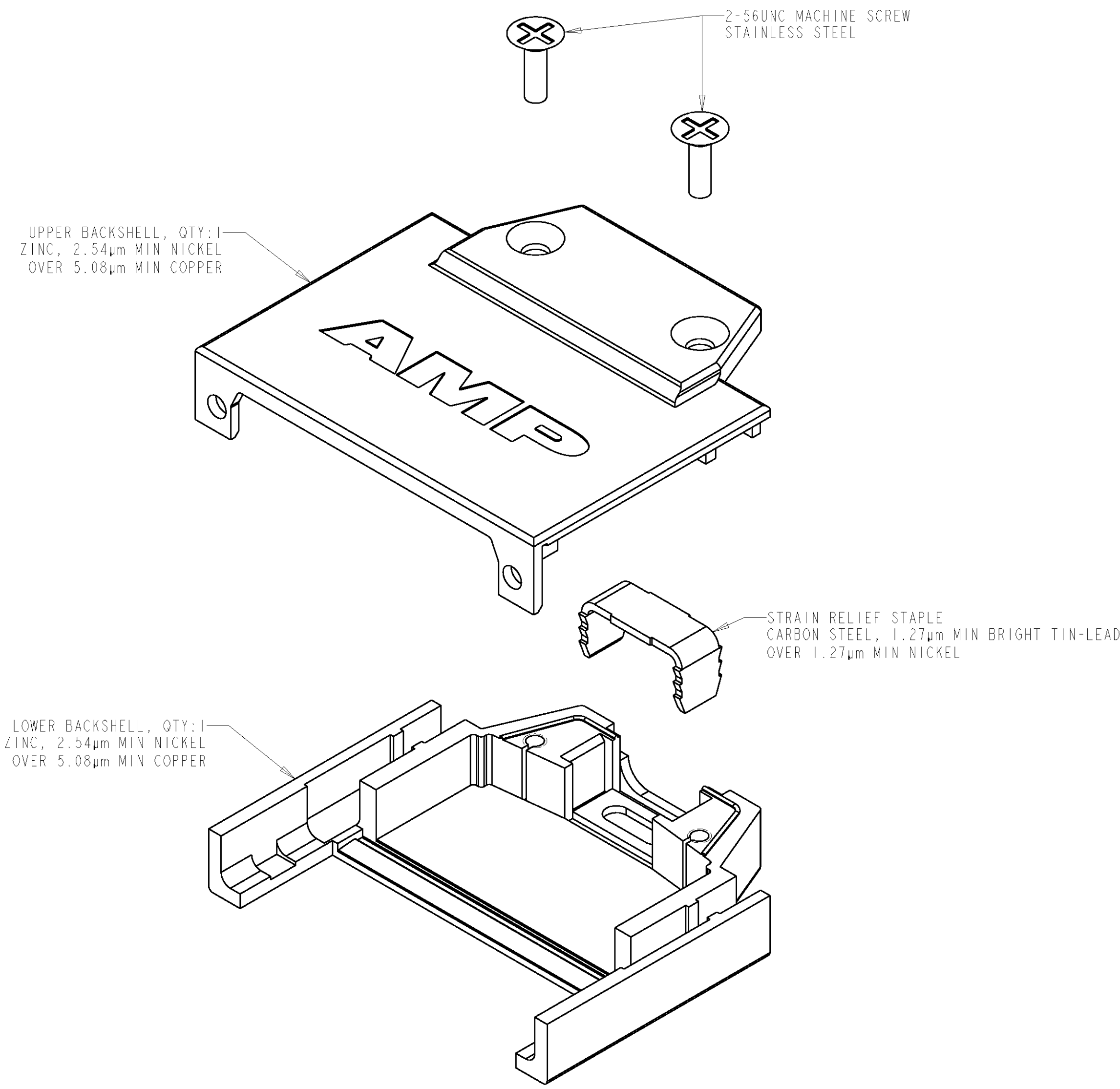

ASSEMBLY INSTRUCTIONS:

1. CABLE PREP LENGTH = 23.5mm
2. WIRE BRAID SHOULD BE ROLED BACK AND TRIMMED TO A MINIMUM OF 6.5mm
3. USE STRAIN RELIEF STAPLE TO ATTACH CABLE TO LOWER BACKSHELL
  - UPPER SURFACE OF STAPLE MUST BE BELOW THE MATING SURFACE OF THE TWO HALVES
  - INSERT STAPLE IN INCREMENTS, UNTIL THE WIRES BETWEEN THE TERMINATION POINT AND STAPLE DO NOT MOVE WHEN GENTLY TWISTING THE CABLE BUNDLE
4. PLACE JACKSCREWS IN PROPER LOCATION
5. ATTACH UPPER BACKSHELL USING THE TWO MACHINE SCREWS

788362-1  
PART NUMBER

<small>THIS DRAWING IS A CONTROLLED DOCUMENT FOR AMP INCORPORATED. IT IS SUBJECT TO CHANGE AND THE CONTROLLING ENGINEERING ORGANIZATION SHOULD BE CONTACTED FOR THE LATEST REVISION.</small>		DWN S. WELDON 24APR98 CHK R. STONE 24APR98 APVD T. BARR 24APR98	<b>AMP</b> AMP Incorporated Harrisburg, PA 17105-3608
DIMENSIONS: mm 	TOLERANCES UNLESS OTHERWISE SPECIFIED: 0 PLC ± 1 PLC ± 2 PLC ±0.13 3 PLC ± 4 PLC ± ANGLES ± FINISH -	PRODUCT SPEC - APPLICATION SPEC - WEIGHT -	NAME BACKSHELL KIT, UNASSEMBLED, 68 POSN, CHAMP 0.8mm SIZE A2 CAGE CODE 00779 DRAWING NO G-788362 RESTRICTED TO - SCALE 3:1 SHEET 1 OF 1 REV A
MATERIAL SEE CALLOUTS	SEE CALLOUTS	CUSTOMER DRAWING	