

# IC0603A103R-10

**UNCONTROLLED DOCUMENT**

**PHYSICAL DIMENSIONS:**

- A 1.80 [.071]  $\pm$  0.15[.006]
- B 0.80 [.031]  $\pm$  0.15[.006]
- C 0.80 [.031]  $\pm$  0.15[.006]
- D 0.30 [.012]  $\pm$  0.20[.008]

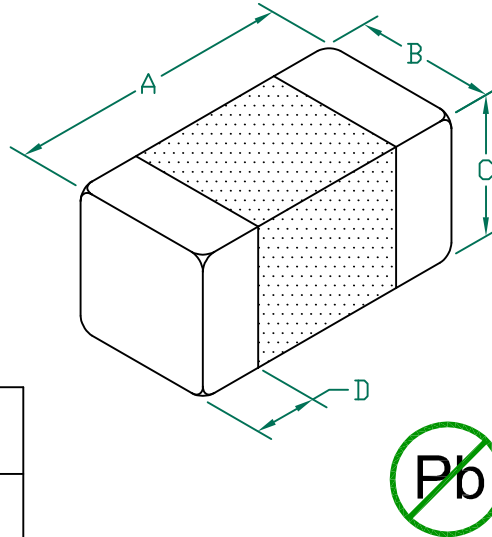

**ELECTRICAL CHARACTERISTICS:**

L (nH) $\pm$ 10%	11,000	Max
	10,000	Nom
	9,000	Min@ 15mA
Q (Min)	30	
Freq. (MHz)	2	
Self-Resonant Freq (MHz)	17	
DCR(Max) $\Omega$	2.55	
I (Max)	100mA	
I (Operating)	15mA	

- NOTES: UNLESS OTHERWISE SPECIFIED
- TAPED AND REELED per CURRENT EIA SPECIFICATIONS 7" REELS, 4000 PCS/REEL, PAPER TAPE.
  - TERMINATION FINISH IS 100% MATTE Sn OVER Ni.
  - COMPONENTS SHOULD BE ADEQUATELY PREHEATED BEFORE SOLDERING.
  - I (MAX.) IS BASED ON THE MAXIMUM SUSTAINED CURRENT APPLIED WHILE MAINTAINING A MAXIMUM TEMPERATURE RISE OF 40°C OVER AMBIENT.
  - I (OPERATING) IS BASED ON THE MAXIMUM SUSTAINED CURRENT APPLIED WHILE MAINTAINING A MINIMUM INDUCTANCE (L).
  - OPERATING TEMP. RANGE: -40°C~+125°C. (INCLUDING SELF-HEATING)

**LAND PATTERNS FOR REFLOW SOLDERING**

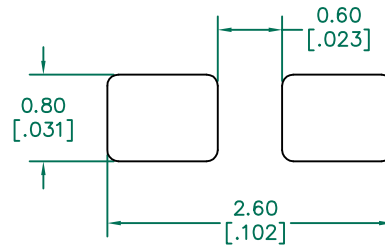

(For wave soldering, add 0.762[.030] to this dimension)

**RECOMMENDED SOLDERING CONDITIONS**

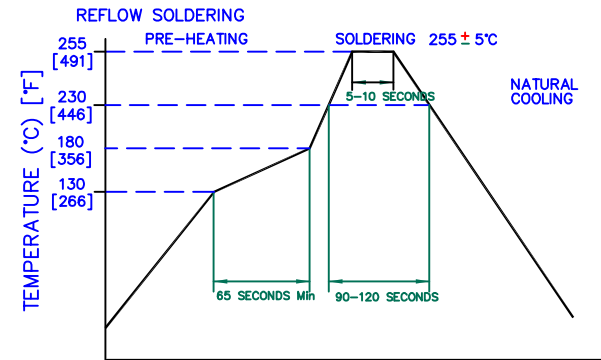

DIMENSIONS ARE IN mm [INCHES].				This print is the property of Laird Tech. and is loaned in confidence subject to return upon request and with the understanding that no copies shall be made without the written consent of Laird Tech. All rights to design or invention are reserved.			
D	ADD OPERATING TEMPERATURE UPDATE LAIRD LOGO AND REFLOW CURVE	08/05/13	QU	PROJECT/PART NUMBER:	REV	PART TYPE:	DRAWN BY:
C	UPDATE COMPANY LOGO	03/25/08	JRK	IC0603A103R-10	D	CO-FIRE	JRK
B	CHANGE DIMENSION A FROM 1.60	03/14/07	JRK	DATE:	SCALE:	NTS	SHEET:
A	ORIGINAL DRAFT	12/27/06	JRK	12/27/06			
REV	DESCRIPTION	DATE	INT	CAD #	TOOL #		2 of 2
				IC0603A103R-10-D			