

IC0805A333R-10

UNCONTROLLED DOCUMENT

PHYSICAL DIMENSIONS:

A	2.00 [.079]	+ 0.20[.008]
B	1.25 [.049]	+ 0.20[.008]
C	1.25 [.049]	+ 0.20[.008]
D	0.50 [.020]	+ 0.30[.012]

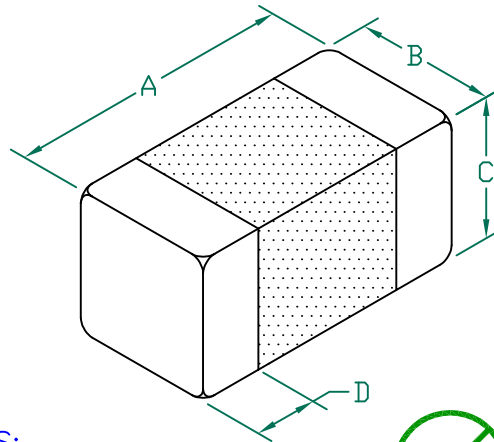

- NOTES: UNLESS OTHERWISE SPECIFIED
1. TAPED AND REELED per CURRENT EIA SPECIFICATIONS 7" REELS, 2000 PCS/REEL, EMBOSSED PLASTIC TAPE.
 2. TERMINATION FINISH IS 100% MATTE Sn OVER Ni.
 3. COMPONENTS SHOULD BE ADEQUATELY PREHEATED BEFORE SOLDERING.
 4. I (MAX.) IS BASED ON THE MAXIMUM SUSTAINED CURRENT APPLIED WHILE MAINTAINING A MAXIMUM TEMPERATURE RISE OF 40°C OVER AMBIENT.
 5. I (OPERATING) IS BASED ON THE MAXIMUM SUSTAINED CURRENT APPLIED WHILE MAINTAINING A MINIMUM INDUCTANCE (L).
 6. OPERATING TEMP. RANGE: -40°C~+125°C. (INCLUDING SELF-HEATING)

ELECTRICAL CHARACTERISTICS:

L (nH) ± 10%	36,300	Max
	33,000	Nom
	29,700	Min@ 5 mA
Q (Min)	30	
Freq. (MHz)	.4	
Self-Resonant Freq (MHz)	13	
DCR(Max) Ω	1.25	
I (Max)	100mA	
I (Operating)	5 mA	

LAND PATTERNS FOR REFLOW SOLDERING

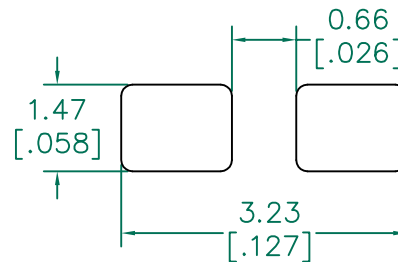

(For wave soldering, add 0.762[.030] to this dimension)

RECOMMENDED SOLDERING CONDITIONS

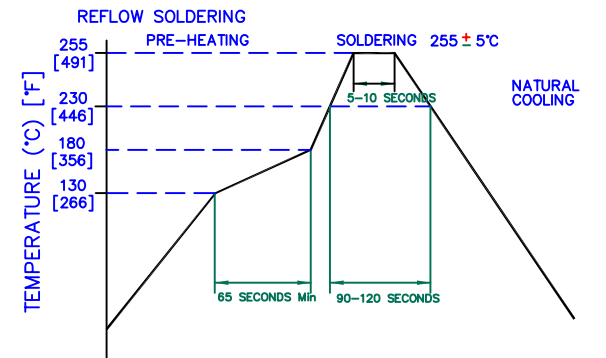

DIMENSIONS ARE IN mm [INCHES].				This print is the property of Laird Tech. and is loaned in confidence subject to return upon request and with the understanding that no copies shall be made without the written consent of Laird Tech. All rights to design or invention are reserved.			
PROJECT/PART NUMBER:				REV	PART TYPE:	DRAWN BY:	
C ADD OPERATING TEMPERATURE UPDATE LAIRD LOGO AND REFLOW CURVE 08/05/13 QU				IC0805A333R-10	C	CO FIRE	JRK
B UPDATE COMPANY LOGO 06/19/08 JRK				DATE:	SCALE:		SHEET:
A ORIGINAL DRAFT 01/02/07 JRK				01/02/07	NTS		
REV DESCRIPTION DATE INT				CAD #	TOOL #	2 of 2	
				IC0805A333R-10-C	-		