

QUICK START GUIDE FOR DEMONSTRATION CIRCUIT 1090A PUSH BUTTON ON/OFF CONTROLLER WITH MICROPROCESSOR INTERRUPT

LTC2954-2

DESCRIPTION

Demonstration Circuit 1090A features the LTC2954-2, a push button ON/OFF controller that manages system power via a push button interface. An enable output toggles system power while an interrupt output provides a debounced push button status. The interrupt output can be used in menu driven applications to request a system power down. A power kill input allows a microprocessor or system to reset the enable output, effectively powering down the system. Independently adjustable On and Off timers allow dependable push button control of the enable output and resistance to accidental toggling of system power.

The LTC2954 operates over a wide 2.7V to 26.4V input voltage range to accommodate a wide variety of input power supplies. Very low quiescent current (6 μ A typical) makes the LTC2954 ideally suited for battery powered applications. Two versions of the part are available to accommodate either positive or negative enable polarities. The inversion of /EN of the LTC2954-2 is found in the LTC2954-1

**Design files for this circuit board are available.
Call the LTC factory.**

LTC is a trademark of Linear Technology Corporation

QUICK START PROCEDURE

Demonstration circuit 1090A is easy to set up to evaluate the performance of the LTC2954-2:

1. Place jumpers in the following positions:

- JP1 CON
- JP2 CPD
- JP3 UNTIE

2. Connect the input power supply of 2.7V to 26.4V across VIN and GND or a 9V battery to the battery connector.
3. Push and hold the push button once to turn on the green LED.
4. Push and hold again on the push button to turn off the green LED.

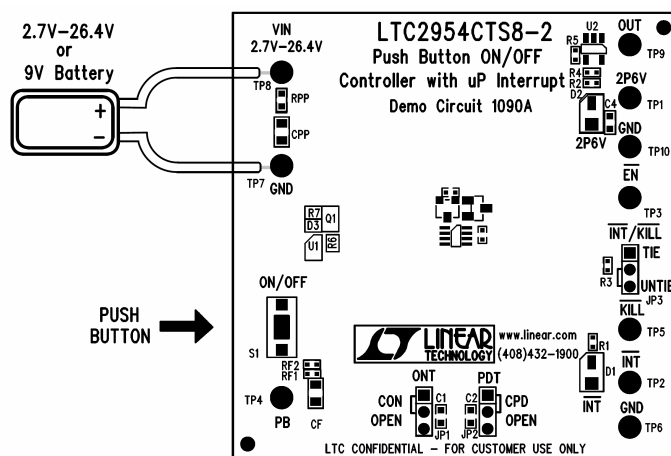

Figure 1. DC1090A Example Setup

OPERATING PRINCIPLES

On the DC1090A, a push button switch shorts the /PB pin to ground which in turn sets the /EN pin low. Shorting /PB to ground a second time and holding subsequently resets the /EN pin high. The /EN pin is used to drive the gate of a P-channel MOSFET to control the power path to a DC/DC converter. The turn on and off of the circuit is displayed with a green LED (D2).

The duration that /PB must be shorted to ground in order to turn on/off the DC/DC converter is independently programmed by two external capacitors C1 and C2 and selected on the DC1090A with jumper JP1 and JP2.

An internal 500ms timer blanks (ignores) the /KILL signal during system power up. This allows sufficient time for the DC/DC converter and a μ P to perform power up tasks. During turn off, a power down timer provides a delay from interrupting the μ P (/INT=low) to turning off the DC/DC converter (/EN=high). This delay gives the μ P time to perform power down and housekeeping tasks. On the DC1090A, JP1 selects the turn on timer, while JP2 is used to adjust the power down /PB duration. The red LED D1 shows the state of the /INT pin. A μ P can turn off the converter with no delay by asserting /KILL low.

By tying /KILL to /INT through JP3, /KILL is forced low during the /INT blanking time and thus forces a turn off.

The RC (R_{RPP} and C_{RPP}) at VIN on the DC1090A provides a reverse polarity protection to the LTC2954-2. If power is connected in an application such that the polarities are ensured to be in the correct configuration, this RC may be removed from the circuit.

An additional RC (R_F and C_F), located at the /PB pin, acts as a filter and used in an application where the switch is located far from the LTC2954-2. In such a case, the RC would be placed next to the switch rather than the part. If the switch is located near the LTC2954-2, then the RC may be removed from the circuit.

An LDO (U2) is used on the DC1090 to provide a pull-up voltage of 2.6V which is well below the absolute maximum on the /INT, /EN, and /KILL pins for the full range of input voltage of 2.7V to 26.4V. In an application, pull these pins up to a voltage no higher than their rated absolute maximum shown in the data sheet. (If the interface pins on the DC1090A are pulled up to an external supply higher than 5V, LEDs D1 and D2 should be removed.)

Table 1. DC1090A Typical Performance Summary ($T_A = 25^\circ\text{C}$)

PARAMETER	CONDITION	VALUE
Input Voltage	V_{IN}	2.7V to 26.4V
Output Voltage	V_{OUT} , /PB Turn On	$V_{IN} - V_{DS}$
	V_{2P6V} , /PB Turn On	$2.6V \pm 2\%$
/PB Turn On Time	JP1 on OPEN	32ms
	JP1 on CAP*	$32 + 212\text{ms}$
/PB Turn Power Down Time	JP2 on OPEN	32ms
	JP2 on CAP*	$32 + 3014\text{ms}$

*The additional Cap. Adjust time is selected by an external capacitor. The DC1090A adjust times have been pre-selected with 0.033 μ F at ONT and 0.47 μ F at CPD to provide additional 212ms and 3014ms turn on and turn power down time respectively. The additional time is calculated with the following equations as shown in the LTC2954 data sheet:

$$C_{ONT} = 1.56 \times 10^{-4} [\mu\text{F/ms}] \cdot (t_{ONT} - 1\text{ms})$$

$$C_{PDT} = 1.56 \times 10^{-4} [\mu\text{F/ms}] \cdot (t_{PDT} - 1\text{ms})$$

QUICK START GUIDE FOR DEMONSTRATION CIRCUIT 1090A PUSH BUTTON ON/OFF CONTROLLER WITH MICROPROCESSOR INTERRUPT

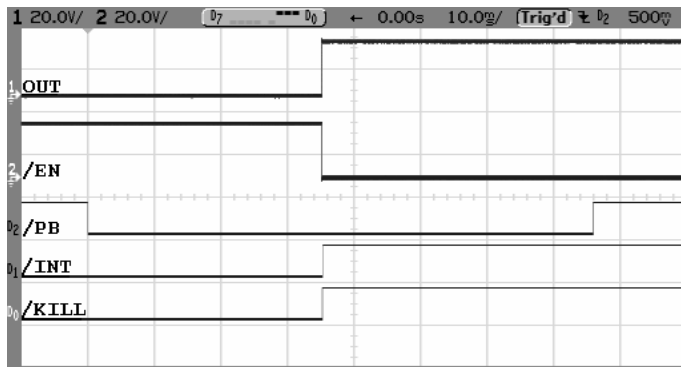

(a) Push Button Turn On



(b) Push Button Turn Off

Figure 2. Push Button Turn On/Off with ONT and PDT Open (time scale at 10ms/div)

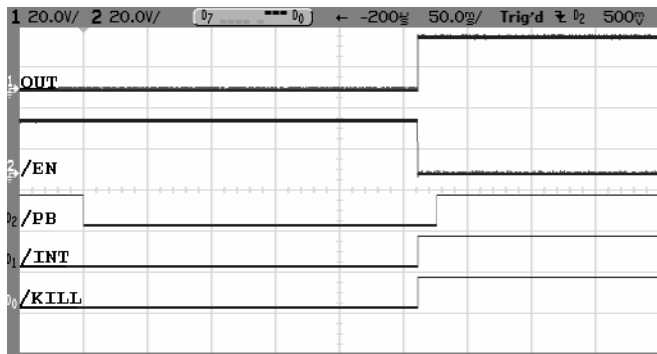

(a) Push Button Turn On (ONT = 0.033µF, 50ms/div)



(b) Push Button Turn Off (PDT = 0.47µF, 500ms/div)

Figure 3. Push Button Turn On/Off with Capacitors on ONT and PDT

QUICK START GUIDE FOR DEMONSTRATION CIRCUIT 1090A PUSH BUTTON ON/OFF CONTROLLER WITH MICROPROCESSOR INTERRUPT

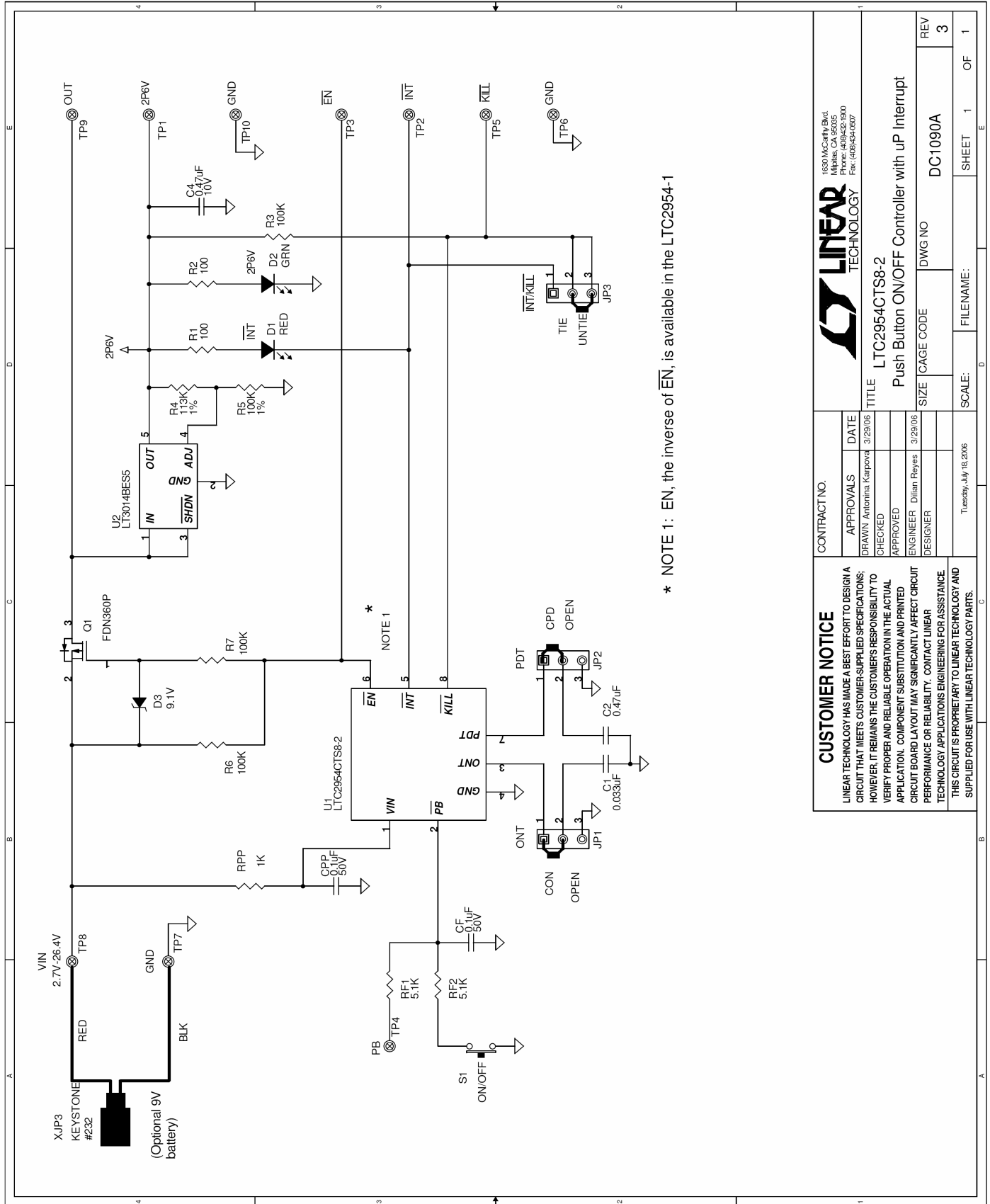

CUSTOMER NOTICE		CONTRACT NO.	
LINEAR TECHNOLOGY HAS MADE A BEST EFFORT TO DESIGN A CIRCUIT THAT MEETS CUSTOMER-SUPPLIED SPECIFICATIONS; HOWEVER, IT REMAINS THE CUSTOMER'S RESPONSIBILITY TO VERIFY PROPER AND RELIABLE OPERATION IN THE ACTUAL APPLICATION. COMPONENT SUBSTITUTION AND PRINTED CIRCUIT BOARD LAYOUT MAY SIGNIFICANTLY AFFECT CIRCUIT PERFORMANCE OR RELIABILITY. CONTACT LINEAR TECHNOLOGY APPLICATIONS ENGINEERING FOR ASSISTANCE. THIS CIRCUIT IS PROPRIETARY TO LINEAR TECHNOLOGY AND SUPPLIED FOR USE WITH LINEAR TECHNOLOGY PARTS.		APPROVALS DATE DRAWN Antonina Karpova 3/29/06 CHECKED APPROVED ENGINEER Dillian Reyes 3/29/06 DESIGNER	
TITLE Push Button ON/OFF Controller with uP Interrupt		DWG NO DC1090A	
SIZE CAGE CODE		SCALE 1 OF 1	
FILENAME:		SHEET 1 OF 1	

LINEAR TECHNOLOGY

LTC2954CTS8-2

Push Button ON/OFF Controller with uP Interrupt

REV 3