

DO NOT SCALE FROM THIS PRINT

| TABLE 1 | |
|------------|-------------|
| LEAD STYLE | CONTACT |
| -02 | C-8-03-XXX |
| -22 | C-17-03-XXX |

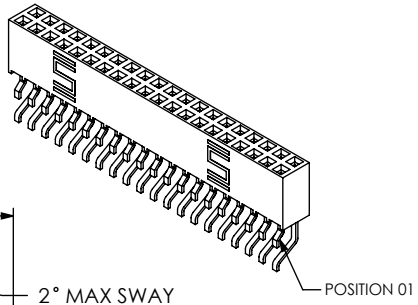

SMH-1XX-XX-XX-X-XX

NO. OF POSITIONS
-02 THRU -36 (PER ROW)

LEAD STYLE
-02: SURFACE MOUNT (USE C-8-03-X)
-22: LOW INSERTION FORCE (USE C-17-03-X)

PLATING
-G: 20μ" OVER IN CONTACT AREA, FLASH GOLD ON TAIL
-T: TIN OVER, MATTE TIN ON TAIL
-S: 30μ" OVER IN CONTACT AREA, MATTE TIN ON TAIL
-F: 3μ" OVER IN CONTACT AREA, MATTE TIN ON TAIL
-H: 30μ" OVER IN CONTACT AREA, FLASH GOLD ON TAIL
-L: 10μ" OVER IN CONTACT AREA, MATTE TIN ON TAIL
-TM: TIN OVER, MATTE TIN ON TAIL
-SM: 30μ" OVER IN CONTACT AREA, MATTE TIN ON TAIL
-FM: 3μ" OVER IN CONTACT AREA, MATTE TIN ON TAIL

OPTIONS
-XX: INDICATES POSITION POLARIZED (USE PK-06-N)
-TR: TAPE & REEL PACKAGING (2 - 29 POSITIONS ONLY)

ROW SPECIFICATION
-D: DOUBLE ROW (USE SMH-50-D) (SEE FIG 1)
-S: SINGLE ROW (USE SSW-50-S) (SEE FIG 2, SHT 2)

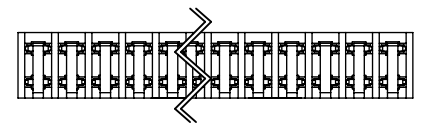
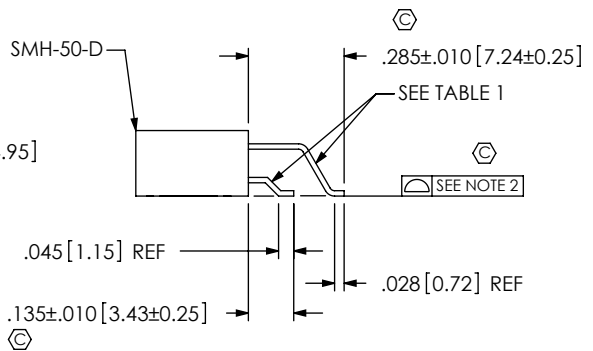
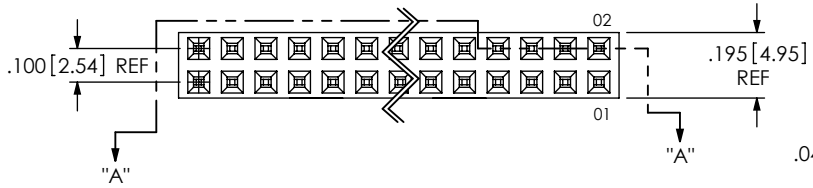
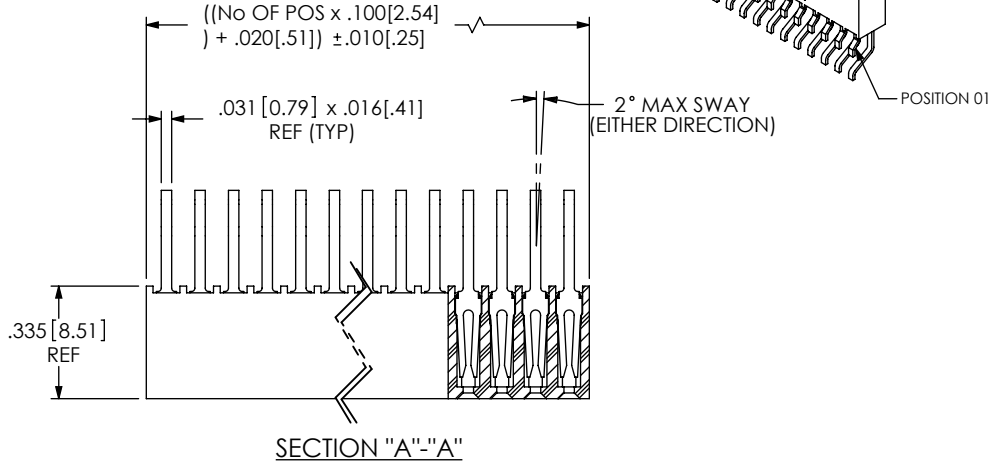
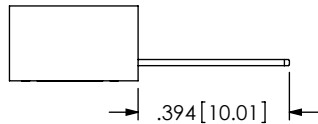

FIG 1
SMH-120-XX-XX-D SHOWN
SEE SHEET 2 FOR IN-PROCESS VIEWS

- NOTES:
1. Ⓢ REPRESENTS A CRITICAL DIMENSION.
 2. COPLANARITY: POSITIONS 02-24= .006[.15], POSITIONS 25-36= .008[.20].
 3. BURR ALLOWANCE: .003[.08] MAX.
 4. ONE POSITION WILL BE LOST FOR EVERY CUT MADE ON A SOCKET STRIP: CUT FLASH TO BE .010 [.25] MAX WITH NO FLASH ALLOWED IN HOLES OR EXTENDING BELOW LEADS
 5. MINIMUM PUSHOUT FORCE: 1.5 LB.
 6. MAXIMUM ALLOWABLE BOW: .003[.08] INCH/INCH AFTER ASSEMBLY.
 7. ENDWALLS AFTER CUTTING: .045 +/- .003.
 8. SHEAR TAILS TO DIMENSION SHOWN.
 9. CONTACT TAILS TO BE FLUSH TO .003[.08] ABOVE OR BELOW A DATUM LINE (MADE BY THE INSULATOR. (-DH ONLY)
 10. NOTE DELETED.
 11. POSITIONS 4 OR LESS SHOULD BE LAYER PACKAGED UNLESS OTHERWISE NOTED IN THE PART CALLOUT.
 12. NOTE DELETED.

| | | | |
|---|---|--|--|
| <p>UNLESS OTHERWISE SPECIFIED, DIMENSIONS ARE IN INCHES.</p> <p>TOLERANCES ARE:</p> <p>DECIMALS ANGLES</p> <p>.XX: ±.01[.3] 2°</p> <p>.XXX: ±.005[.13]</p> <p>.XXXX: ±.0020[.051]</p> | <p>PROPRIETARY NOTE</p> <p>THIS DOCUMENT CONTAINS CONFIDENTIAL AND PROPRIETARY INFORMATION AND ALL DESIGN, MANUFACTURING, REPRODUCTION, USE, PATENT RIGHTS AND SALES RIGHTS ARE EXPRESSLY RESERVED BY SAMTEC, INC. THIS DOCUMENT SHALL NOT BE DISCLOSED, IN WHOLE OR PART, TO ANY UNAUTHORIZED PERSON OR ENTITY NOR REPRODUCED, TRANSFERRED OR INCORPORATED IN ANY OTHER PROJECT IN ANY MANNER WITHOUT THE EXPRESS WRITTEN CONSENT OF SAMTEC, INC.</p> | | |
| | | <p>520 PARK EAST BLVD., NEW ALBANY, IN 47150 PHONE: 812-944-6733 FAX: 812-948-5047 e-Mail: info@SAMTEC.com code: 55322</p> | |
| <p>MATERIAL: DO NOT SCALE DRAWING SHEET SCALE: 2:1</p> <p>INSULATOR: LCP, UL 94 VO, COLOR: BLACK CONTACT: PHOSPHOR BRONZE</p> | | <p>DESCRIPTION: .100 [2.54] HORIZONTAL SMT SOCKET ASSEMBLY</p> <p>DWG. NO. SMH-1XX-XX-XX-X-XX</p> | |
| <p>F:\DWG\MISC\MKTG\SMH-1XX-XX-XX-X-XX-MKT.SLDDRW</p> | | <p>BY: BRATCHER 2/5/99 SHEET 1 OF 3</p> | |



IN-PROCESS 1

MUST FILL WITH DIE SIDE OF PIN FACING DOWN, PINS ARE STAMPED WITH A SQUARE INDICATOR MARK ON DIE SIDE

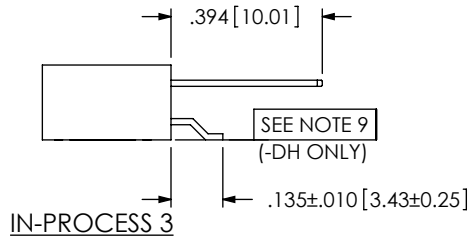

IN-PROCESS 3

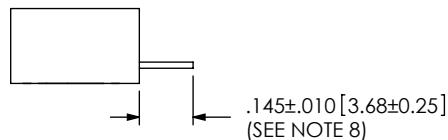
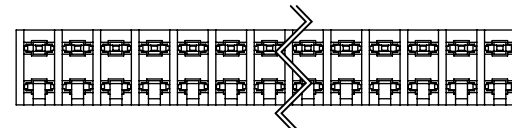

IN-PROCESS 2

MUST FILL WITH DIE SIDE OF PIN FACING DOWN, PINS ARE STAMPED WITH A SQUARE INDICATOR MARK ON DIE SIDE

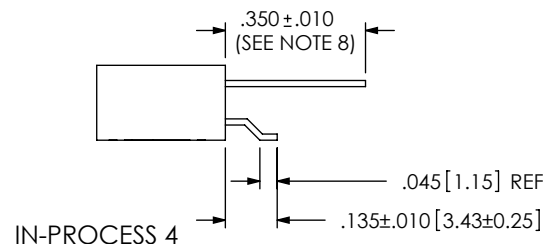

IN-PROCESS 4

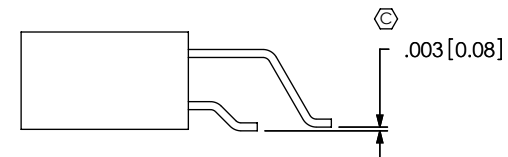
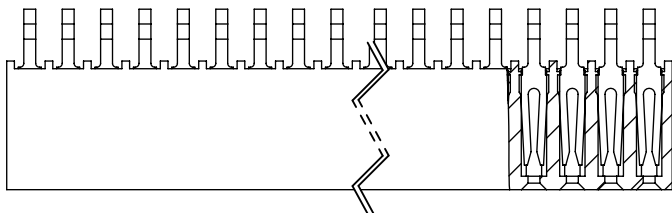

IN-PROCESS 5
TAILS MUST BE WITHIN +/- .003 WITH RESPECT TO EACH OTHER.

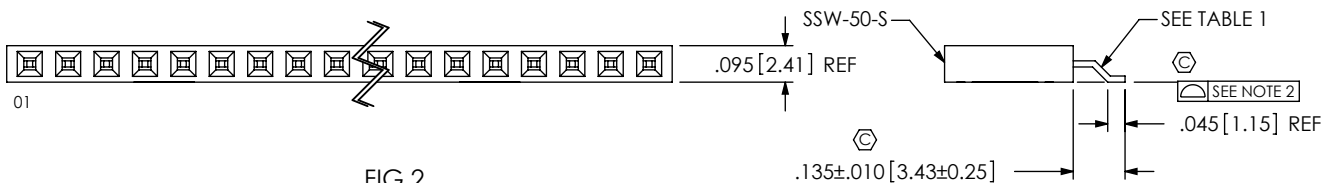
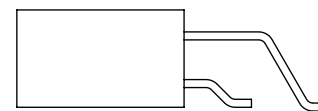
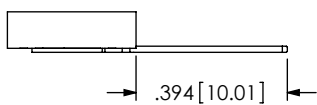
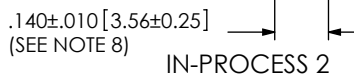

FIG 2
SMH-120-XX-XX-S SHOWN
(SAME AS FIG 1, UNLESS OTHERWISE STATED)

F:\DWG\MISC\MKTG\SMH-1XX-XX-XX-X-XX-MKT.SLDDRW



IN-PROCESS 1



IN-PROCESS 2

PROPRIETARY NOTE
THIS DOCUMENT CONTAINS CONFIDENTIAL AND PROPRIETARY INFORMATION AND ALL DESIGN, MANUFACTURING, REPRODUCTION, USE, PATENT RIGHTS AND SALES RIGHTS ARE EXPRESSLY RESERVED BY SAMTEC, INC. THIS DOCUMENT SHALL NOT BE DISCLOSED, IN WHOLE OR PART, TO ANY UNAUTHORIZED PERSON OR ENTITY NOR REPRODUCED, TRANSFERRED OR INCORPORATED IN ANY OTHER PROJECT IN ANY MANNER WITHOUT THE EXPRESS WRITTEN CONSENT OF SAMTEC, INC.

DO NOT SCALE DRAWING

SHEET SCALE: 2:1



520 PARK EAST BLVD, NEW ALBANY, IN 47150
PHONE: 812-944-6733 FAX: 812-948-5047
e-Mail: info@SAMTEC.com code: 55322

DESCRIPTION:
.100 [2.54] HORIZONTAL SMT SOCKET ASSEMBLY

DWG. NO.
SMH-1XX-XX-XX-X-XX

BY: BRATCHER 2/5/99 SHEET 2 OF 3

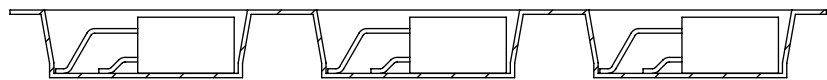
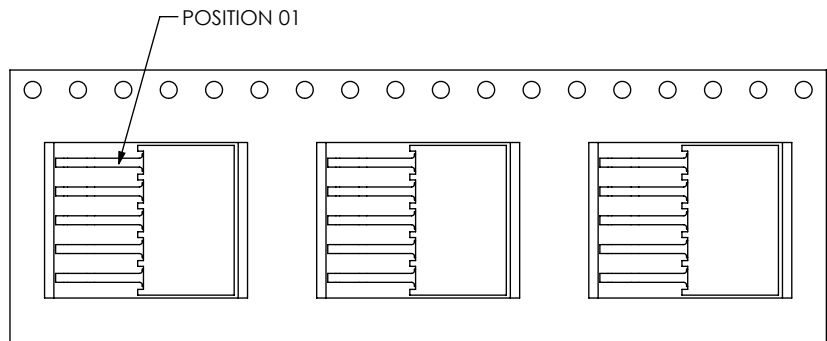

USER DIRECTION OF REELING →
POCKET NOT DETAILED

SHM-105-XX-XX-D-TR SHOWN

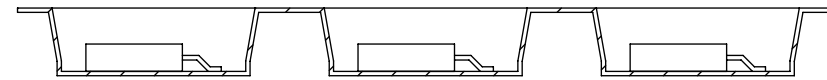
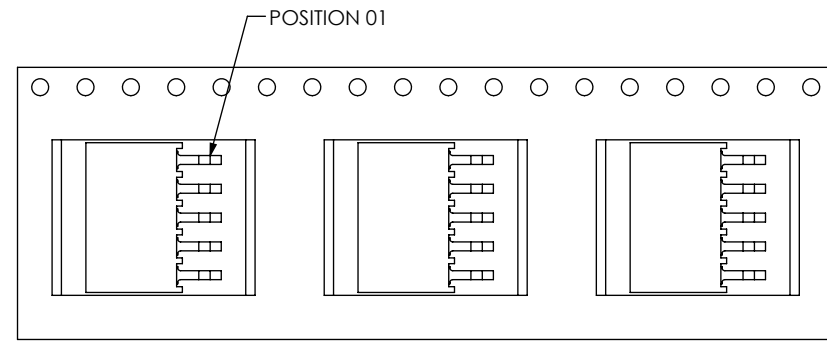

USER DIRECTION OF REELING →
POCKET NOT DETAILED

SHM-105-XX-XX-S-TR SHOWN

-TR PACKAGING VIEW

TUBE PACKAGING

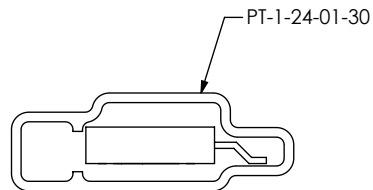
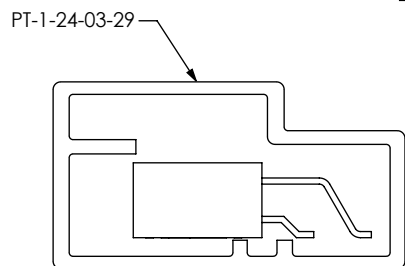

SEE NOTE 11

| TABLE 2 | | |
|---------|---------------|-------|
| ROW | TUBE | PLUG |
| -S | PT-1-24-01-30 | TP-07 |
| -D | PT-1-24-03-29 | TP-07 |

PROPRIETARY NOTE
THIS DOCUMENT CONTAINS CONFIDENTIAL AND PROPRIETARY INFORMATION AND ALL DESIGN, MANUFACTURING, REPRODUCTION, USE, PATENT RIGHTS AND SALES RIGHTS ARE EXPRESSLY RESERVED BY SAMTEC, INC. THIS DOCUMENT SHALL NOT BE DISCLOSED, IN WHOLE OR PART, TO ANY UNAUTHORIZED PERSON OR ENTITY NOR REPRODUCED, TRANSFERRED OR INCORPORATED IN ANY OTHER PROJECT IN ANY MANNER WITHOUT THE EXPRESS WRITTEN CONSENT OF SAMTEC, INC.

DO NOT SCALE DRAWING

SHEET SCALE: 2:1



520 PARK EAST BLVD., NEW ALBANY, IN 47150
PHONE: 812-944-6733 FAX: 812-948-5047
e-Mail: info@SAMTEC.com code: 55322

DESCRIPTION:
.100 [2.54] HORIZONTAL SMT SOCKET ASSEMBLY

DWG. NO.
SMH-1XX-XX-XX-X-XX

BY: BRATCHER 2/5/99 SHEET 3 OF 3