

DESIGNED & DIMENSIONED
IN MILLIMETERS [INCHES]

ZF5S-XX-XX-X-WT-X-XX

No. OF POSITIONS
-04 THRU -50
(USE ZF5-XX AND
ZF5C-XX)

LEAD STYLE
-01: USE C-297-01-T
-02: USE C-297-03-T
-03: USE C-297-02-T & C-297-04-T

OPTION
-TR: TAPE AND REEL

OPTION
-K: KAPTON PAD
(N/A IN -03 LEAD STYLE)
(USE K-DOT-.118-.219-.005)
(SEE SHEET 4, FIG 3)

WELD TAB
USE WT-60-01-T

PLATING SPECIFICATION
-T: PURE TIN, MATTE FINISH

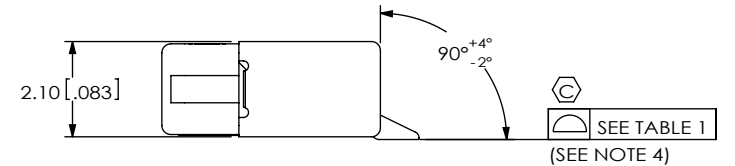
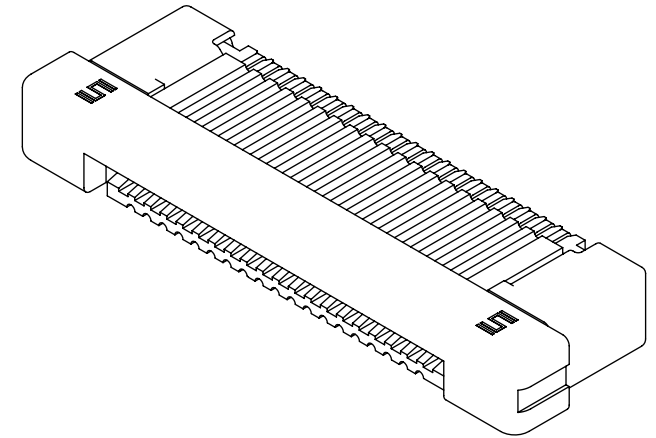
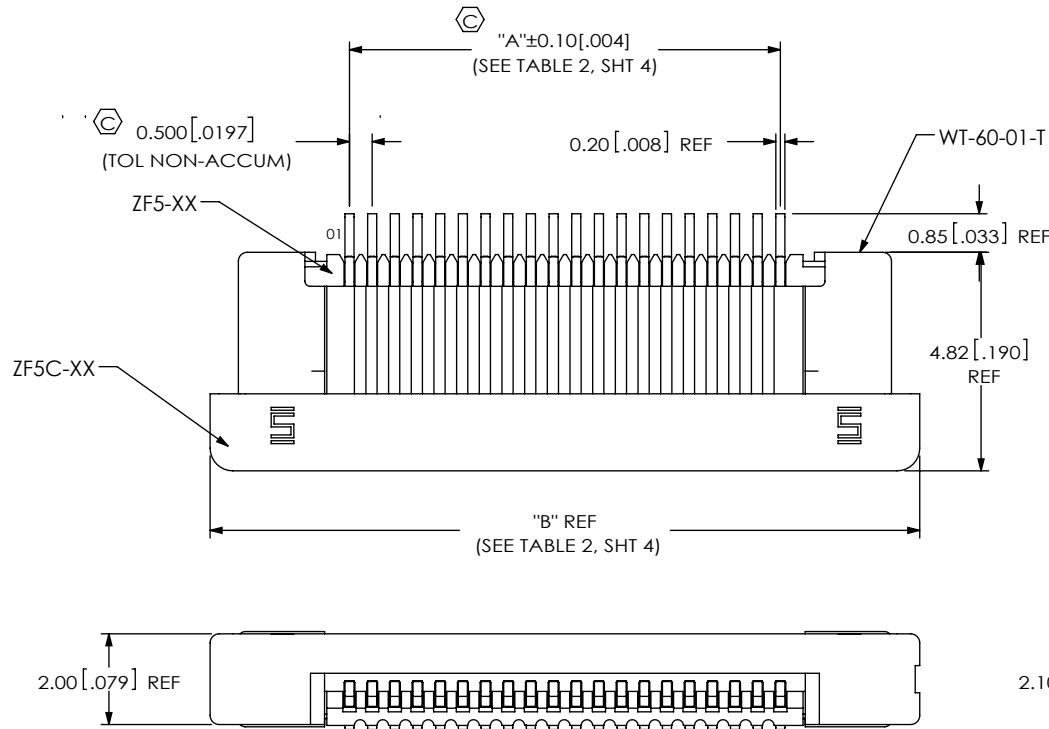

No OF POS.	COPLANARITY
-04 THRU -30	0.10 [0.004]
-31 THRU -50	0.15 [0.006]

FIG 1
ZF5S-20-01-T-WT SHOWN
(WITH CAM CLOSED)

NOTES:

1. C REPRESENTS A CRITICAL DIMENSION.
2. MAXIMUM BURR ALLOWANCE: 0.025 [0.0010]
3. MINIMUM PUSHOUT FORCE: 6 OZ
4. CO-PLANARITY INCLUDES TAILS AND WELD TABS.
5. WELD TAB RETENTION: 6 OZ
6. BREAKOFF BURR NOT TO EXCEED 0.18 [0.007] AND MUST REMAIN ATTACHED.
7. PIN 1 TO HAVE ORIENTATION AS SHOWN.

<p>UNLESS OTHERWISE SPECIFIED, DIMENSIONS ARE IN MILLIMETERS. TOLERANCES ARE:</p> <p>DECIMALS ANGLES</p> <p>X.X: ±0.3 [01] 2°</p> <p>X.XX: ±0.13 [005]</p> <p>X.XXX: ±0.051 [0020]</p>	<p>PROPRIETARY NOTE</p> <p>THIS DOCUMENT CONTAINS CONFIDENTIAL AND PROPRIETARY INFORMATION AND ALL DESIGN, MANUFACTURING, REPRODUCTION, USE, PATENT RIGHTS AND SALES RIGHTS ARE EXPRESSLY RESERVED BY SAMTEC, INC. THIS DOCUMENT SHALL NOT BE DISCLOSED, IN WHOLE OR PART, TO ANY UNAUTHORIZED PERSON OR ENTITY NOR REPRODUCED, TRANSFERRED OR INCORPORATED IN ANY OTHER PROJECT IN ANY MANNER WITHOUT THE EXPRESS WRITTEN CONSENT OF SAMTEC, INC.</p>	<p>520 PARK EAST BLVD, NEW ALBANY, IN 47150 PHONE: 812-944-6733 FAX: 812-948-5047 e-Mail: info@SAMTEC.com code 55322</p>
<p>F:\DWG\MISC\MKTG\ZF5S-XX-XX-X-WT-X-XX-MKT.SLDDRW</p>		<p>BY: G PURVIS 01/20/2011 SHEET 1 OF 5</p>

REVISION X

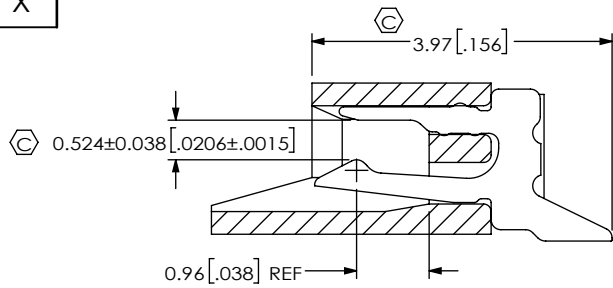

-01 LEAD STYLE
IN PROCESS 1
FILL C-297-01-T

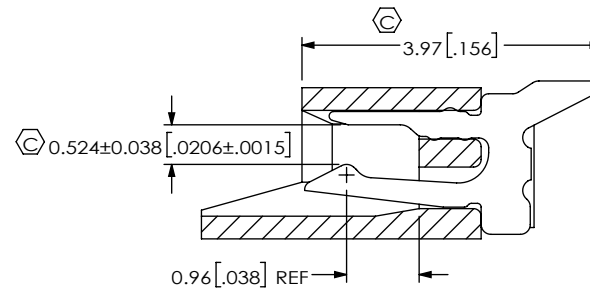

-02 LEAD STYLE
IN PROCESS 1
FILL C-297-03-T

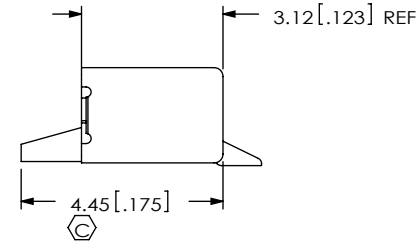
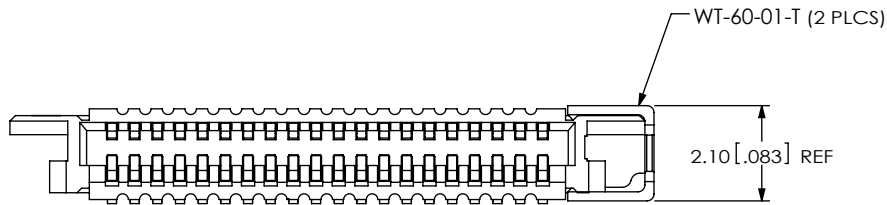

IN PROCESS 2
FILL WT-60-01-T
(SOME FEATURES REMOVED FOR CLARITY)

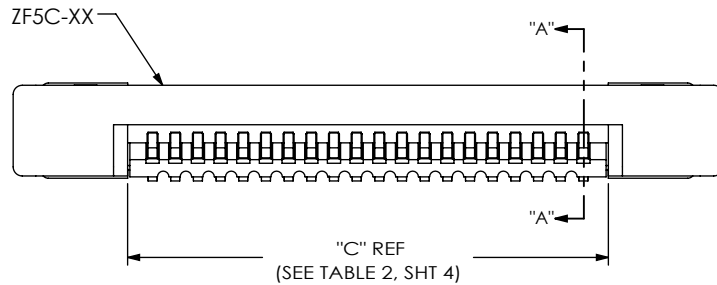

IN PROCESS 3
INSERT ZF5C-XX-XX
(CAM SHOWN IN CLOSED POSITION)

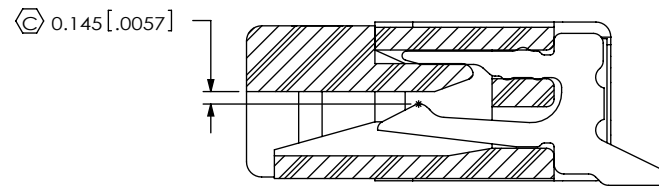

SECTION "A"-"A"

PROPRIETARY NOTE
THIS DOCUMENT CONTAINS CONFIDENTIAL AND PROPRIETARY INFORMATION AND ALL DESIGN, MANUFACTURING, REPRODUCTION, USE, PATENT RIGHTS AND SALES RIGHTS ARE EXPRESSLY RESERVED BY SAMTEC, INC. THIS DOCUMENT SHALL NOT BE DISCLOSED, IN WHOLE OR PART, TO ANY UNAUTHORIZED PERSON OR ENTITY NOR REPRODUCED, TRANSFERRED OR INCORPORATED IN ANY OTHER PROJECT IN ANY MANNER WITHOUT THE EXPRESS WRITTEN CONSENT OF SAMTEC, INC.

DO NOT SCALE DRAWING

SHEET SCALE: 10:1

samtec

520 PARK EAST BLVD, NEW ALBANY, IN 47150
PHONE: 812-944-6733 FAX: 812-948-5047
e-Mail: info@SAMTEC.com code 55322

DESCRIPTION:
ZERO INSERTION FORCE .5mm ASSEMBLY

DWG. NO.
ZF5S-XX-XX-X-WT-X-XX

BY: G PURVIS 01/20/2011 SHEET 2 OF 5

FIG 2
 -03 LEAD STYLE
 (DIFFERENT AS SHOWN, OTHERWISE SAME AS FIG 1)
 (ZF5S-20-03-T-WT SHOWN)

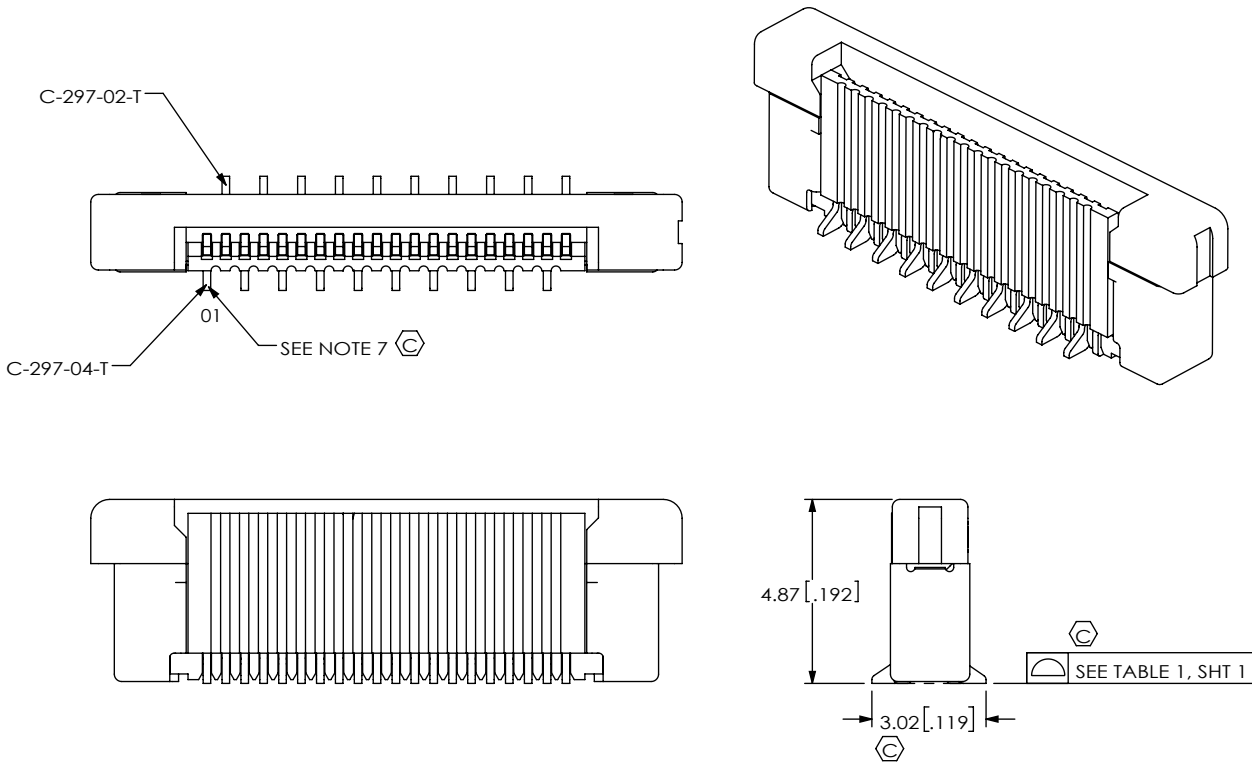

APPLICATION VIEWS

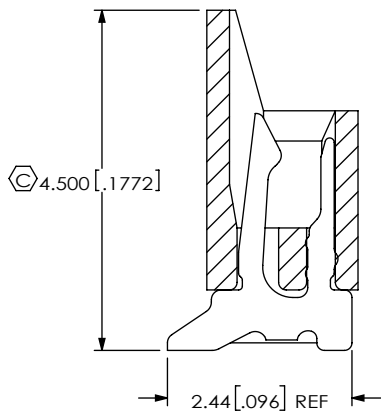
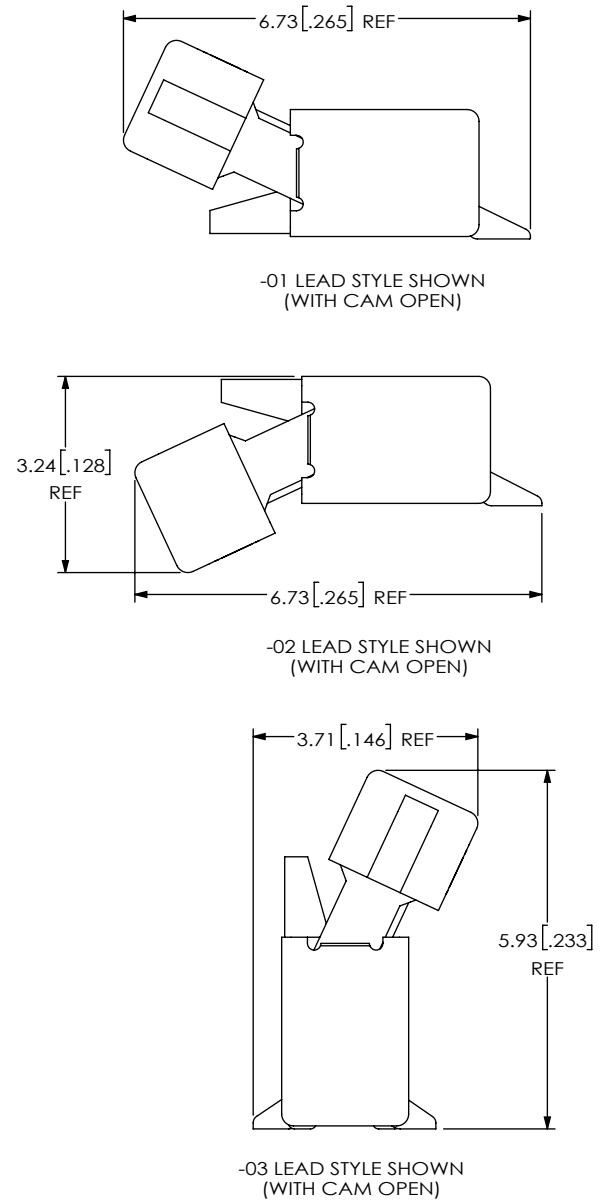

-03 LEAD STYLE
IN PROCESS 1A
 FILL C-297-04-T
 (SAME AS IN PROCESS 1 FOR -01 LEAD
 STYLE EXCEPT AS SHOWN)
 (ODD POSITIONS FILLED ONLY)

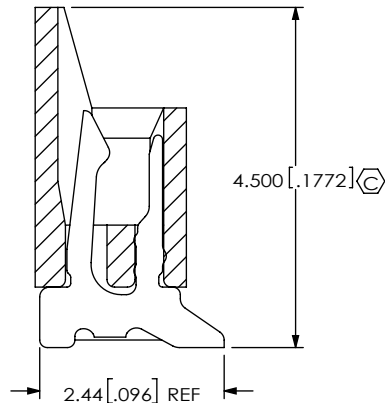

-03 LEAD STYLE
IN PROCESS 1B
 FILL C-297-02-T
 (SAME AS IN PROCESS 1 FOR -01 LEAD
 STYLE EXCEPT AS SHOWN)
 (EVEN POSITIONS FILLED ONLY)

PROPRIETARY NOTE
 THIS DOCUMENT CONTAINS CONFIDENTIAL AND
 PROPRIETARY INFORMATION AND ALL DESIGN,
 MANUFACTURING, REPRODUCTION, USE, PATENT RIGHTS
 AND SALES RIGHTS ARE EXPRESSLY RESERVED BY SAMTEC,
 INC. THIS DOCUMENT SHALL NOT BE DISCLOSED, IN WHOLE
 OR PART, TO ANY UNAUTHORIZED PERSON OR ENTITY NOR
 REPRODUCED, TRANSFERRED OR INCORPORATED IN ANY
 OTHER PROJECT IN ANY MANNER WITHOUT THE EXPRESS
 WRITTEN CONSENT OF SAMTEC, INC.

DO NOT SCALE DRAWING

SHEET SCALE: 5:1

samtec

520 PARK EAST BLVD, NEW ALBANY, IN 47150
 PHONE: 812-944-6733 FAX: 812-948-5047
 e-Mail: info@SAMTEC.com code 55322

DESCRIPTION:
 ZERO INSERTION FORCE .5mm ASSEMBLY

DWG. NO.
ZF5S-XX-XX-X-WT-X-XX

BY: G PURVIS 01/20/2011 SHEET 3 OF 5

TABLE 2

No OF POS	"A"	"B"	"C"	"D"
-04	1.50 [0.059]	7.65 [0.301]	2.60 [0.102]	2.32 [0.091]
-05	2.00 [0.079]	8.15 [0.321]	3.10 [0.122]	2.57 [0.101]
-06	2.50 [0.098]	8.65 [0.341]	3.60 [0.142]	2.82 [0.111]
-07	3.00 [0.118]	9.15 [0.360]	4.10 [0.161]	3.07 [0.121]
-08	3.50 [0.138]	9.65 [0.380]	4.60 [0.181]	3.32 [0.131]
-09	4.00 [0.157]	10.15 [0.400]	5.10 [0.201]	3.57 [0.141]
-10	4.50 [0.177]	10.65 [0.419]	5.60 [0.220]	3.82 [0.150]
-11	5.00 [0.197]	11.15 [0.439]	6.10 [0.240]	4.07 [0.160]
-12	5.50 [0.217]	11.65 [0.459]	6.60 [0.260]	4.32 [0.170]
-13	6.00 [0.236]	12.15 [0.478]	7.10 [0.280]	4.57 [0.180]
-14	6.50 [0.256]	12.65 [0.498]	7.60 [0.299]	4.82 [0.190]
-15	7.00 [0.276]	13.15 [0.518]	8.10 [0.319]	5.07 [0.200]
-16	7.50 [0.295]	13.65 [0.537]	8.60 [0.339]	5.32 [0.209]
-17	8.00 [0.315]	14.15 [0.557]	9.10 [0.358]	5.57 [0.219]
-18	8.50 [0.335]	14.65 [0.577]	9.60 [0.378]	5.82 [0.229]
-19	9.00 [0.354]	15.15 [0.596]	10.10 [0.398]	6.07 [0.239]
-20	9.50 [0.374]	15.65 [0.616]	10.60 [0.417]	6.32 [0.249]
-21	10.00 [0.394]	16.15 [0.636]	11.10 [0.437]	6.57 [0.259]
-22	10.50 [0.413]	16.65 [0.656]	11.60 [0.457]	6.82 [0.269]
-23	11.00 [0.433]	17.15 [0.675]	12.10 [0.476]	7.07 [0.278]
-24	11.50 [0.453]	17.65 [0.695]	12.60 [0.496]	7.32 [0.288]
-25	12.00 [0.472]	18.15 [0.715]	13.10 [0.516]	7.57 [0.298]
-26	12.50 [0.492]	18.65 [0.734]	13.60 [0.535]	7.82 [0.308]
-27	13.00 [0.512]	19.15 [0.754]	14.10 [0.555]	8.07 [0.318]
-28	13.50 [0.531]	19.65 [0.774]	14.60 [0.575]	8.32 [0.328]
-29	14.00 [0.551]	20.15 [0.793]	15.10 [0.594]	8.57 [0.337]
-30	14.50 [0.571]	20.65 [0.813]	15.60 [0.614]	8.82 [0.347]
-31	15.00 [0.591]	21.15 [0.833]	16.10 [0.634]	9.07 [0.357]
-32	15.50 [0.610]	21.65 [0.852]	16.60 [0.654]	9.32 [0.367]
-33	16.00 [0.630]	22.15 [0.872]	17.10 [0.673]	9.57 [0.377]
-34	16.50 [0.650]	22.65 [0.892]	17.60 [0.693]	9.82 [0.387]
-35	17.00 [0.669]	23.15 [0.911]	18.10 [0.713]	10.07 [0.396]
-36	17.50 [0.689]	23.65 [0.931]	18.60 [0.732]	10.32 [0.406]
-37	18.00 [0.709]	24.15 [0.951]	19.10 [0.752]	10.57 [0.416]
-38	18.50 [0.728]	24.65 [0.970]	19.60 [0.772]	10.82 [0.426]
-39	19.00 [0.748]	25.15 [0.990]	20.10 [0.791]	11.07 [0.436]
-40	19.50 [0.768]	25.65 [1.010]	20.60 [0.811]	11.32 [0.446]
-41	20.00 [0.787]	26.15 [1.030]	21.10 [0.831]	11.57 [0.456]
-42	20.50 [0.807]	26.65 [1.049]	21.60 [0.850]	11.82 [0.465]
-43	21.00 [0.827]	27.15 [1.069]	22.10 [0.870]	12.07 [0.475]
-44	21.50 [0.846]	27.65 [1.089]	22.60 [0.890]	12.32 [0.485]
-45	22.00 [0.866]	28.15 [1.108]	23.10 [0.909]	12.57 [0.495]
-46	22.50 [0.886]	28.65 [1.128]	23.60 [0.929]	12.82 [0.505]
-47	23.00 [0.906]	29.15 [1.148]	24.10 [0.949]	13.07 [0.515]
-48	23.50 [0.925]	29.65 [1.167]	24.60 [0.969]	13.32 [0.524]
-49	24.00 [0.945]	30.15 [1.187]	25.10 [0.988]	13.57 [0.534]
-50	24.50 [0.965]	30.65 [1.207]	25.60 [1.008]	13.82 [0.544]

FIG 3
KAPTON PAD
(USE K-DOT-.118-.219-.005)
(DIFFERENT AS SHOWN, OTHERWISE SAME AS FIG 1)

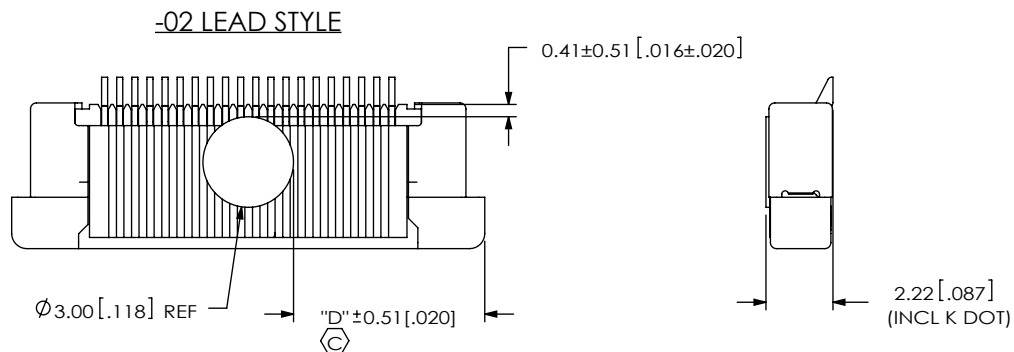
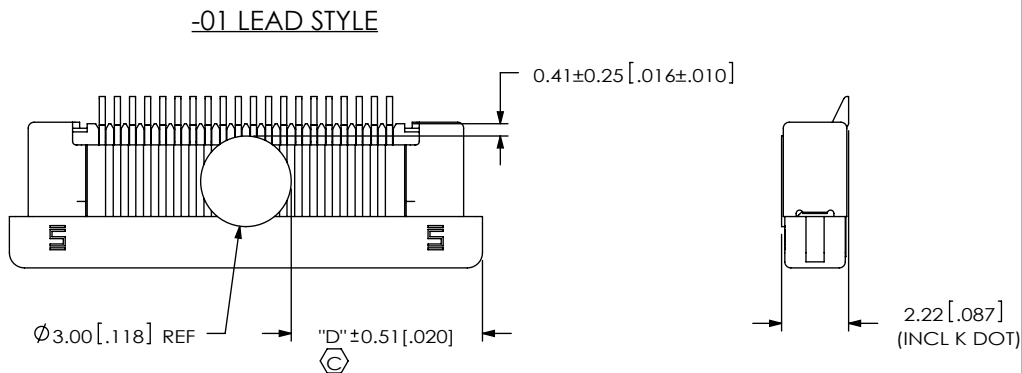

PROPRIETARY NOTE
THIS DOCUMENT CONTAINS CONFIDENTIAL AND PROPRIETARY INFORMATION AND ALL DESIGN, MANUFACTURING, REPRODUCTION, USE, PATENT RIGHTS AND SALES RIGHTS ARE EXPRESSLY RESERVED BY SAMTEC, INC. THIS DOCUMENT SHALL NOT BE DISCLOSED, IN WHOLE OR PART, TO ANY UNAUTHORIZED PERSON OR ENTITY NOR REPRODUCED, TRANSFERRED OR INCORPORATED IN ANY OTHER PROJECT IN ANY MANNER WITHOUT THE EXPRESS WRITTEN CONSENT OF SAMTEC, INC.



520 PARK EAST BLVD., NEW ALBANY, IN 47150
PHONE: 812-944-6733 FAX: 812-948-5047
e-Mail: info@SAMTEC.com code 55322

SHEET SCALE: 4:1

DESCRIPTION:
ZERO INSERTION FORCE .5mm ASSEMBLY

DWG. NO.
ZF5S-XX-XX-X-WT-X-XX

BY: G PURVIS 01/20/2011 SHEET 4 OF 5

PACKAGING VIEWS

-01 LEAD STYLE
SHOWN WITH -K OPTION

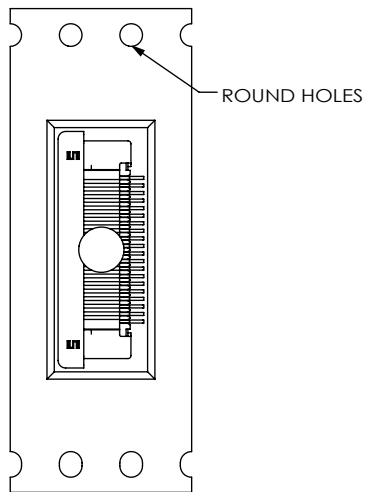

USER DIRECTION OF UN-REELING
POCKET NOT DETAILED →

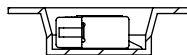

-02 LEAD STYLE
SHOWN WITH -K OPTION

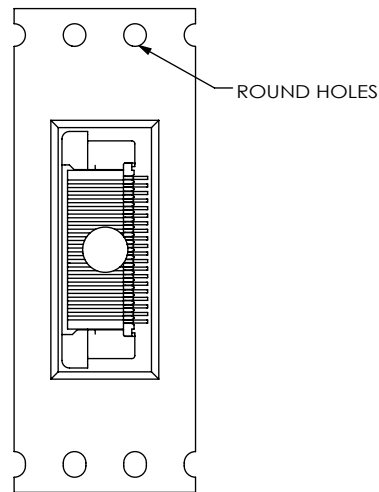

USER DIRECTION OF UN-REELING
POCKET NOT DETAILED →

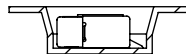

-03 LEAD STYLE

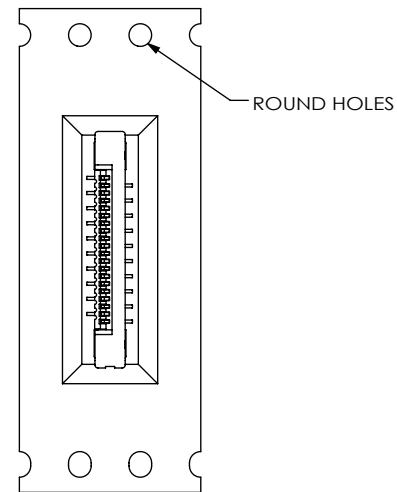

USER DIRECTION OF UN-REELING
POCKET NOT DETAILED →

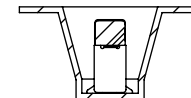

PACKAGING VIEWS
[PARTS TO HAVE POSITION #1 LOADED IN
SAME DIRECTION AS ARROW ON TUBE]

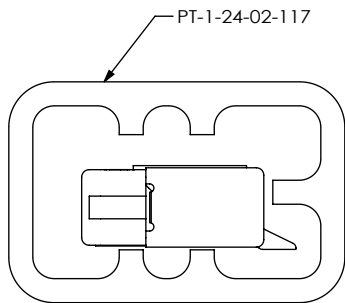

-01 LEAD STYLE
(USE TP-24-02 PLUG)

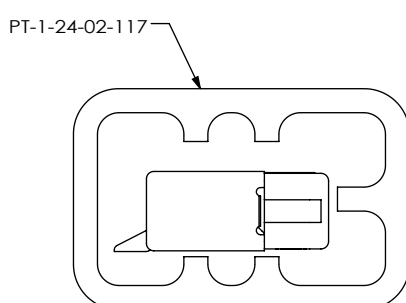

-02 LEAD STYLE
(USE TP-24-02 PLUG)

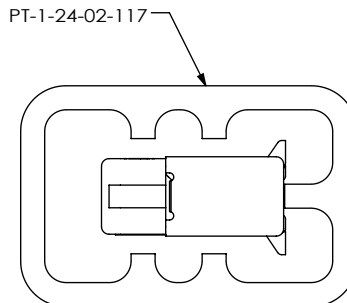

-03 LEAD STYLE
(USE TP-24-02 PLUG)

F:\DWG\MISC\MKTG\ZF55-XX-XX-X-WT-X-XX-MKT.SLDDRW

PROPRIETARY NOTE
THIS DOCUMENT CONTAINS CONFIDENTIAL AND PROPRIETARY INFORMATION AND ALL DESIGN, MANUFACTURING, REPRODUCTION, USE, PATENT RIGHTS AND SALES RIGHTS ARE EXPRESSLY RESERVED BY SAMTEC, INC. THIS DOCUMENT SHALL NOT BE DISCLOSED, IN WHOLE OR PART, TO ANY UNAUTHORIZED PERSON OR ENTITY NOR REPRODUCED, TRANSFERRED OR INCORPORATED IN ANY OTHER PROJECT IN ANY MANNER WITHOUT THE EXPRESS WRITTEN CONSENT OF SAMTEC, INC.

DO NOT SCALE DRAWING

SHEET SCALE: 10:1



520 PARK EAST BLVD, NEW ALBANY, IN 47150
PHONE: 812-944-6733 FAX: 812-948-5047
e-Mail: info@SAMTEC.com code 55322

DESCRIPTION:
ZERO INSERTION FORCE .5mm ASSEMBLY

DWG. NO.
ZF55-XX-XX-X-WT-X-XX

BY: G PURVIS 01/20/2011 SHEET 5 OF 5