

Dynamometer Drive System



Features

- Two BLDC motors connected in a dyno setup (BLY171S-24V-4000 and BLY171D-24V-4000)
- Electronically adjustable load – the load value is set using the onboard buttons + LCD
- Programmable step and ramp load changes
- Measurement and display of load motor phase currents
- Measurement and display of load motor speed

Block Diagram

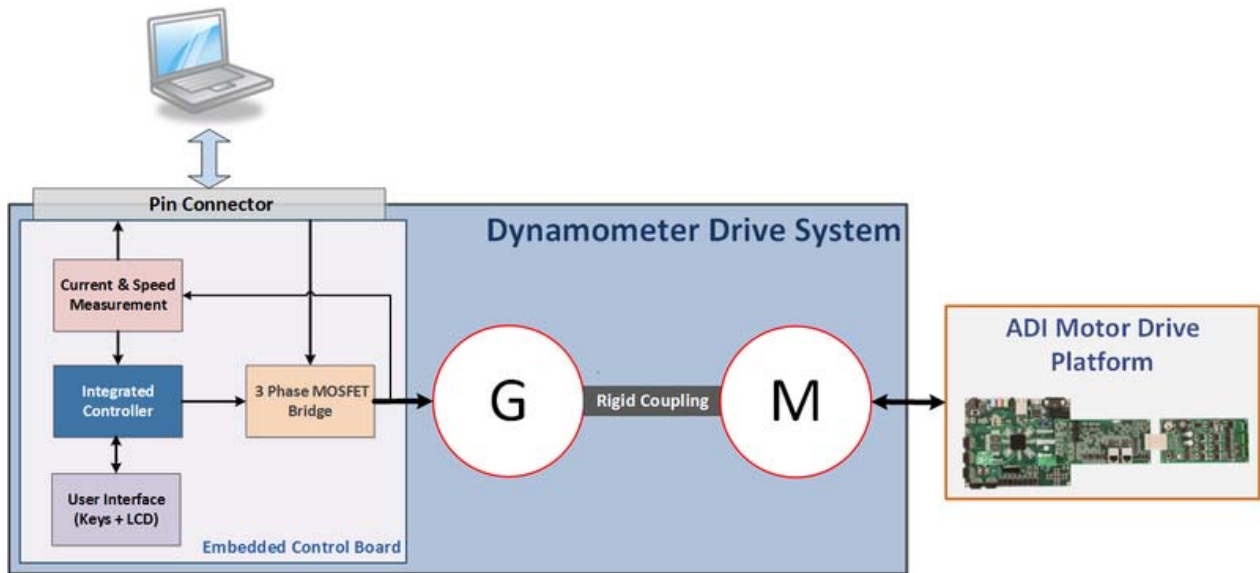

Key Parts

Power

ADuM5000	isoPower® integrated isolated dc-to-dc converter
ADP3335	HIGH ACCURACY ULTRALOW QUIESCENT CURRENT, 500 mA, ANYCAP® LOW DROPOUT

Isolation

ADUM3223	3 KV RMS ISOLATED PRECISION HALF-BRIDGE DRIVER, 4 A OUTPUT
-----------------	--

Control

ADUC7023	Precision Analog Microcontroller, 12-Bit Analog I/O, ARM7TDMI MCU with Enhanced IRQ Handler
-----------------	---

User Guide

The system is equipped with an LCD which displays information about the state of the load such and together with the 3 push buttons placed below it can be used to display and configure different system parameters. The **+/-** buttons are used to navigate through the system's menu and to change different system parameters, while the **Enter** button is used to confirm parameter changes or to enter / exit the menu screens

Menu diagram

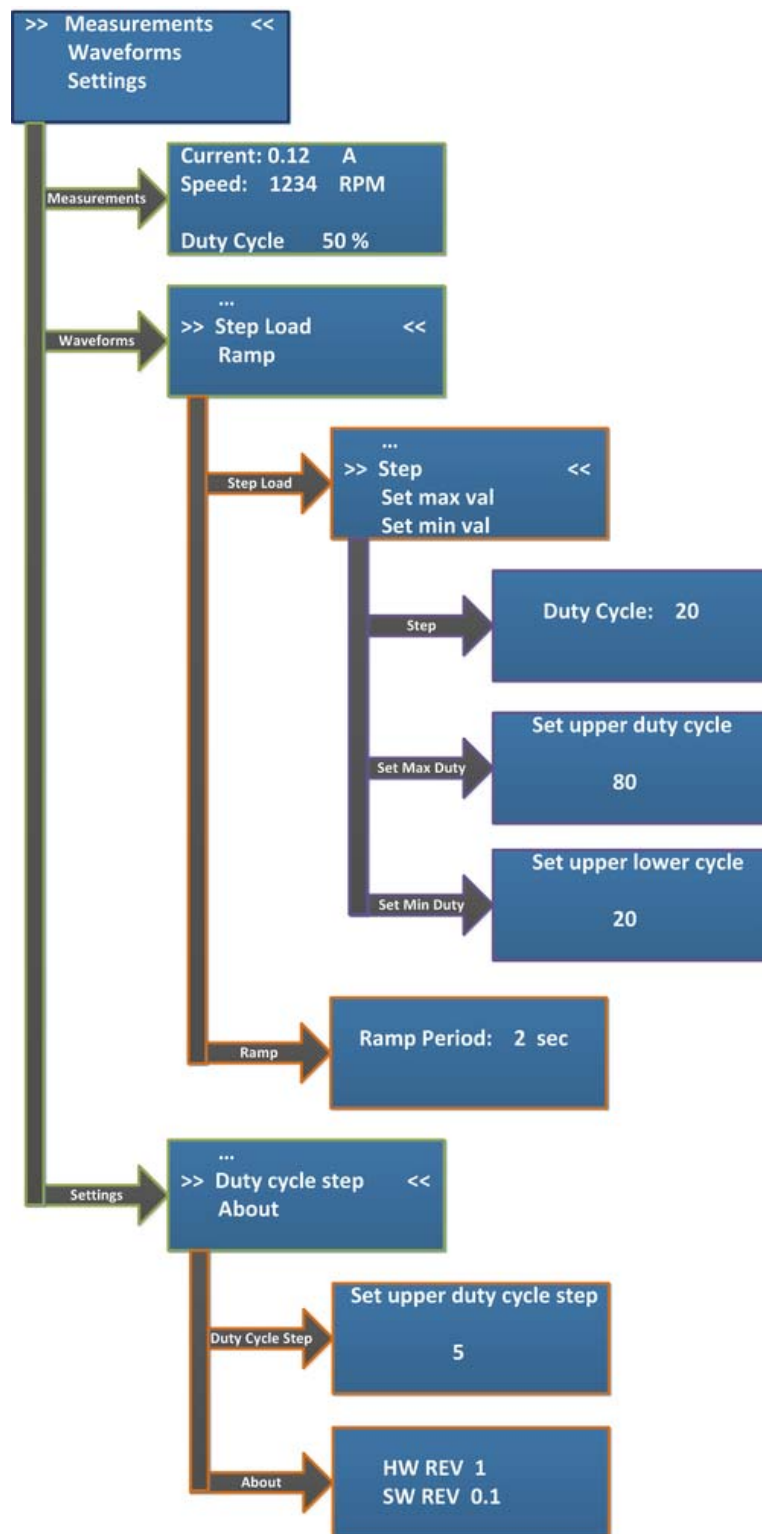

Menu description

Main menu is displayed at power up.
The measurement menu displays RMS phase currents and motor speed. The load can be adjusted by pressing the “+” or “-” buttons. In order to go back to the main menu press “Enter”.
Waveforms menu. Select ramp or step load. In order to go back select “...” and press “Enter”
Step load menu. Select “Step” to start toggling the load.
Press “+” or “-” to toggle between the preset step values. In order to go back press “Enter”
Set maximum duty cycle. In order to go back press “Enter”
Set minimum duty cycle. In order to go back press “Enter”
Ramp load menu. Press “+” or “-” to change ramp period. In order to go back press “Enter”
Settings menu. In order to go back select “...” and press “Enter”
Change duty cycle step.
About.

External Control

In order interface the Dyno with an external control system:

- Slide switch S2 to EXT_CTRL position
- Connect to the header P1



The external available signals are:

Dyno Signal	Description
I_A	Phase A motor current (185mv/A)
I_B	Phase B motor current (185mv/A)
PWM1	Phase A PWM (3.3V levels)
PWM2	Phase B PWM (3.3V levels)
PWM3	Phase C PWM (3.3V levels)

The system needs a 5V 500mA power supply. The power connector is a 2.1 X 5.5MM jack with the center pin positive(+)

Downloads

AD-DYNO2-EBZ

- Schematics
- Bill of Materials
- Allegro Board File (This file is compressed). Get the Allegro FREE Physical Viewer (You need 16.5 or higher).

Navigation - AD-FMCMOTCON2-EBZ
Prev.: Signal Measurement ChainUp: Overview

<https://wiki.analog.com/resources/eval/user-guides/ad-fmcmotcon2-ebz/hardware/dyno-9-19-18>