

Temperature Compensated Directional Power Detector 6 - 18 GHz

Rev. V1

Features

- Integrated Directional Coupler
- Low Insertion Loss: 0.27 dB @ 12 GHz
- Minimum Detectable Power: -16 dBm @ 12 GHz
- Built-In Temperature Compensation
- Lead-Free 1.5 x 1.2 mm 6-Lead TDFN Plastic Package
- Halogen-Free “Green” Mold Compound
- RoHS* Compliant and 260°C Reflow Compatible

Description

The MACP-010572 belongs to a series of small, easy-to-use, broadband, directional detectors. With integrated low loss directional couplers and built-in temperature compensation circuits, these detectors provide an easy way to monitor the power of a signal travelling in a specific direction along a transmission line. Detectors are housed in a miniature, surface mount, lead less plastic package. They require a small amount of bias for proper performance. The total bias current is less than 0.5 mA.

Typical applications include power monitoring and leveling in Point-to-Point radios, IMS, Radar, VSAT, EW, and Aerospace & Defense systems.

The surface mount package is small yet can be handled and placed with standard pick and place assembly equipment. Detectors are fabricated on a well established GaAs process featuring full passivation for performance and reliability.

Functional Schematic

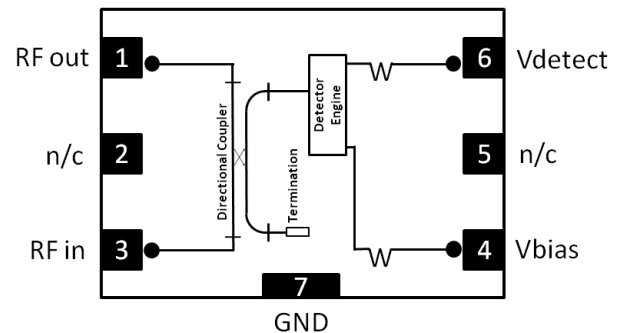

Pin Configuration³

Pin #	Pin Name	Description
1	RF _{OUT}	RF Output
2	N/C	No Connection ³
3	RF _{IN}	RF Input
4	V _{BIAS}	Bias Voltage
5	N/C	No Connection ³
6	V _{DET}	Detector Voltage
7	GND	Ground

3. Pins 2 and 5 are not connected internally and should not be used for grounding. Package has exposed bottom metal pad (Pin 7) which should be connected to the circuit ground. The parasitic inductance introduced by this connection should be as small as possible.

Ordering Information^{1,2}

Part #	Package
MACP-010572-TR1000	1000 part reel
MACP-010572-001SMB	Sample Board

1. Reference Application Note M513 for reel size information.
2. All sample boards include 5 loose parts.

* Restrictions on Hazardous Substances, European Union Directive 2011/65/EU.

Temperature Compensated Directional Power Detector 6 - 18 GHz

Rev. V1

Electrical Specifications:

Freq. = 12 GHz, $T_A = 25^\circ\text{C}$, $V_B = +3.2\text{ V}$, $Z_0 = 50\ \Omega$ (unless otherwise specified)

Parameter	Test Conditions	Units	Min.	Typ.	Max.
Insertion Loss	6 GHz 12 GHz 18 GHz	dB	—	0.15 0.27 0.67	—
Detect Voltage	10 dBm applied to Input 6 GHz 12 GHz 18 GHz	mV	—	190 360 550	—
Directivity	Into 50 Ω load 6 GHz 12 GHz 18 GHz	dB	—	21 16 12	—
Sensitivity	Minimum recommended power level 6 GHz 12 GHz 18 GHz	dBm	—	-10 -16 -21	—
Maximum Power	Maximum recommended power level 6 - 18 GHz	dBm	—	30	—
Input Return Loss	6 GHz 12 GHz 18 GHz	dB	—	23 30 13	—
Output Return Loss	6 GHz 12 GHz 18 GHz	dB	—	22 31 14	—
DC Offset	Detect voltage with no RF input power	mV	50	100	150
Bias Current	$V_{\text{Bias}} = 3.2\text{ V}$	mA	—	0.3	0.35

Absolute Maximum Ratings^{4,5}

Parameter	Absolute Maximum
Input Power	+40 dBm
Operating Voltage	8 V
Operating Temperature	-40°C to +85°C
Storage Temperature	-65°C to +150°C

- Exceeding any one or combination of these limits may cause permanent damage to this device.
- MACOM does not recommend sustained operation near these survivability limits.

Handling Procedures

Please observe the following precautions to avoid damage:

Static Sensitivity

Gallium Arsenide Integrated Circuits are sensitive to electrostatic discharge (ESD) and can be damaged by static electricity. Proper ESD control techniques should be used when handling these HBM Class 0A devices.

Application Information

The MACP-010572 is designed to deliver high performance and to be easy to use.

No external components are needed. The RF connections required by the MACP-010572 are shown in a schematic below.

Pin 3 should be connected to the RF line bringing the input signal. Pin 1 is the RF output. The third required connection is that to the RF ground. The exposed metal paddle on the back of the package must be connected to the RF ground of the board housing the detector. This can be accomplished by using conductive via holes. It is important to ensure that the parasitic inductance associated with the connection between the detector and the RF ground is as small as possible. The RF ground also provides the return path for the DC bias current.

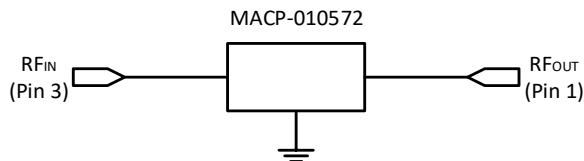

DC Bias

The MACP-010572 operates with a positive 3.2 V bias applied to pin 4. The output voltage is available on pin 6.

Recommended PCB Configuration

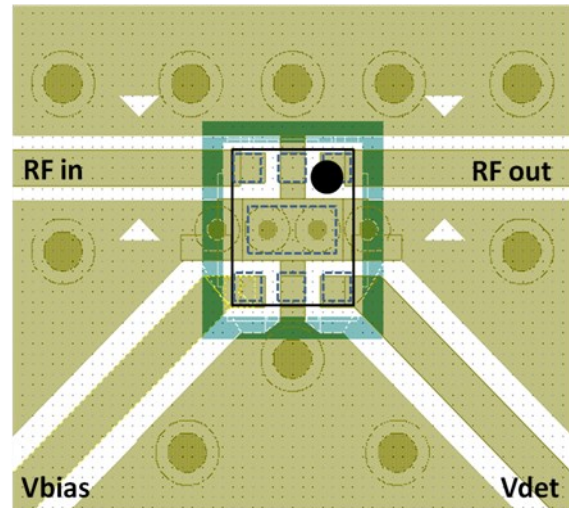

Evaluation Board

MACOM will supply an evaluation board and loose samples upon qualified request. The kit consists of a PCB and SMA connectors. MACOM suggests a Rogers 4350 dielectric of 0.008" (0.20 mm) with 1/2 ounce copper. Proper grounding is always important, we suggest 8 mil (0.20 mm) vias placed generously underneath the part.

Temperature Compensated Directional Power Detector 6 - 18 GHz

Rev. V1

Typical Performance Curves:

Insertion Loss

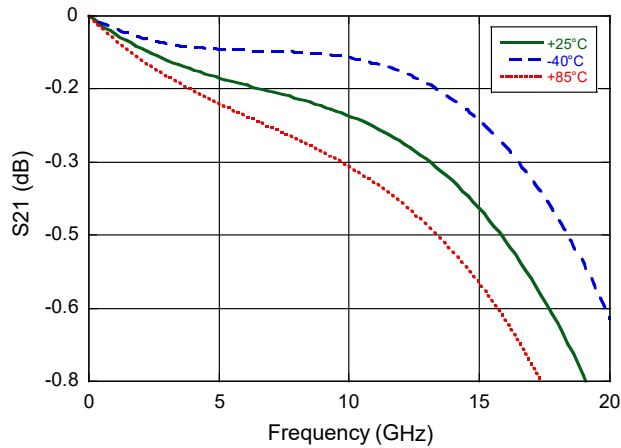

Detect Voltage vs. Input Power

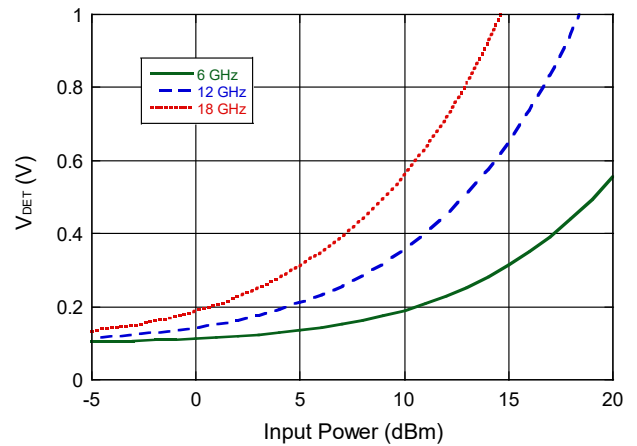

Input Return Loss

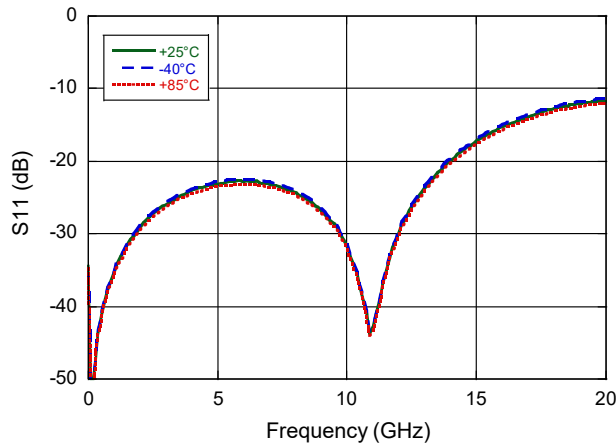

Output Return Loss

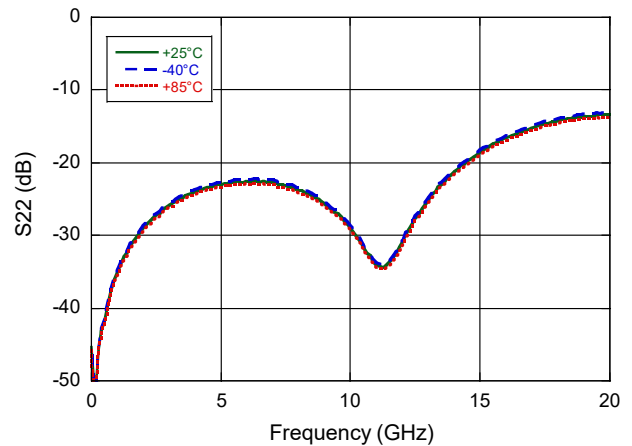

Directivity

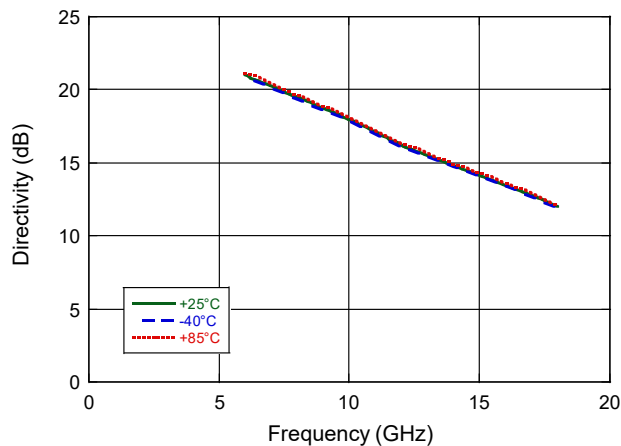

Temperature Compensation Accuracy

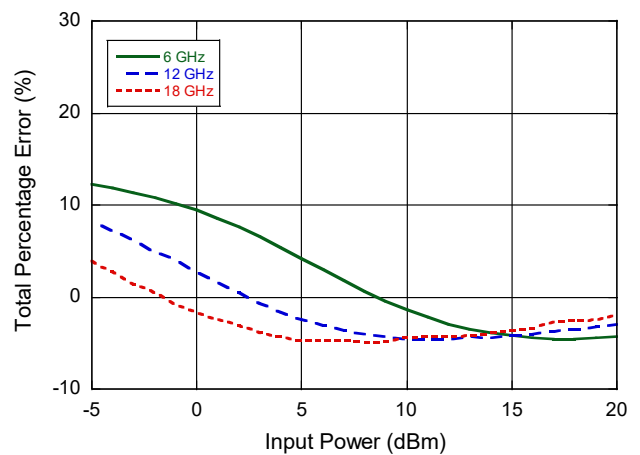

Lead-Free 1.5 x 1.2 mm 6-Lead

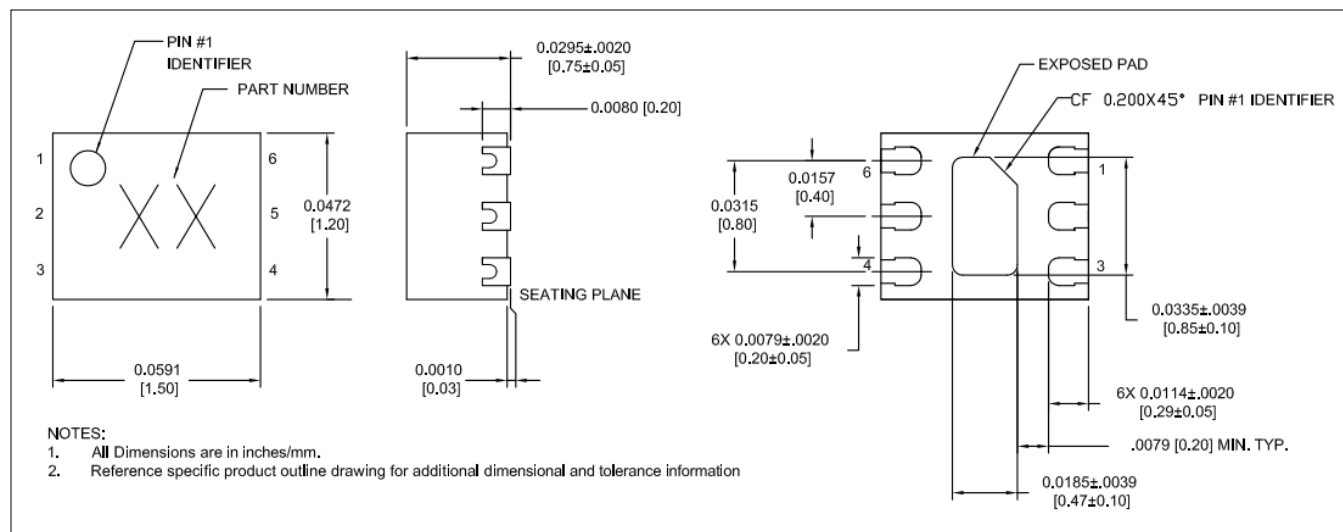

† Reference Application Note S2083 for lead-free solder reflow recommendations.
Meets JEDEC moisture sensitivity level 1 requirements
Plating is NiPdAuAg.

MACOM Technology Solutions Inc. All rights reserved.

Information in this document is provided in connection with MACOM Technology Solutions Inc ("MACOM") products. These materials are provided by MACOM as a service to its customers and may be used for informational purposes only. Except as provided in MACOM's Terms and Conditions of Sale for such products or in any separate agreement related to this document, MACOM assumes no liability whatsoever. MACOM assumes no responsibility for errors or omissions in these materials. MACOM may make changes to specifications and product descriptions at any time, without notice. MACOM makes no commitment to update the information and shall have no responsibility whatsoever for conflicts or incompatibilities arising from future changes to its specifications and product descriptions. No license, express or implied, by estoppels or otherwise, to any intellectual property rights is granted by this document.

THESE MATERIALS ARE PROVIDED "AS IS" WITHOUT WARRANTY OF ANY KIND, EITHER EXPRESS OR IMPLIED, RELATING TO SALE AND/OR USE OF MACOM PRODUCTS INCLUDING LIABILITY OR WARRANTIES RELATING TO FITNESS FOR A PARTICULAR PURPOSE, CONSEQUENTIAL OR INCIDENTAL DAMAGES, MERCHANTABILITY, OR INFRINGEMENT OF ANY PATENT, COPYRIGHT OR OTHER INTELLECTUAL PROPERTY RIGHT. MACOM FURTHER DOES NOT WARRANT THE ACCURACY OR COMPLETENESS OF THE INFORMATION, TEXT, GRAPHICS OR OTHER ITEMS CONTAINED WITHIN THESE MATERIALS. MACOM SHALL NOT BE LIABLE FOR ANY SPECIAL, INDIRECT, INCIDENTAL, OR CONSEQUENTIAL DAMAGES, INCLUDING WITHOUT LIMITATION, LOST REVENUES OR LOST PROFITS, WHICH MAY RESULT FROM THE USE OF THESE MATERIALS.

MACOM products are not intended for use in medical, lifesaving or life sustaining applications. MACOM customers using or selling MACOM products for use in such applications do so at their own risk and agree to fully indemnify MACOM for any damages resulting from such improper use or sale.