

Description

Single or multipole hydraulic-magnetic circuit breakers with trip-free mechanism and toggle actuation. A choice of switching characteristics ensures suitability for a wide range of applications. Industry standard dimensions and panel mounting. Auxiliary contacts optional. Low temperature sensitivity at rated load. Approved to CBE standard EN 60934 (IEC 60934) S-type HM CBE.

Typical applications

In the business fields Communication and Transport: power supplies, switchgear, instrumentation and process control engineering.

Standard current ratings and typical internal resistance values

| Current rating (A) | Trip curves and internal resistance (Ω) per pole | | | |
|--------------------|--|---------|------------|------------|
| | F1 | F2 | K1, M1, T1 | K2, M2, T2 |
| 0,05 | --- | --- | 531 | 542 |
| 0,1 | --- | --- | 129 | 127 |
| 1 | 0,578 | 0,347 | 1,10 | 1,08 |
| 2 | 0,144 | 0,0959 | 0,295 | 0,291 |
| 3 | 0,0644 | 0,0477 | 0,121 | 0,118 |
| 5 | 0,0250 | 0,0192 | 0,0437 | 0,0449 |
| 10 | 0,00901 | 0,00714 | 0,0147 | 0,0133 |
| 15 | 0,00597 | 0,00483 | 0,00794 | 0,00794 |
| 20 | 0,00468 | 0,00410 | 0,00597 | 0,00597 |
| 25 | 0,00410 | 0,00385 | 0,00456 | 0,00456 |
| 30 | 0,00385 | 0,00371 | 0,00458 | 0,00458 |
| 40 | 0,00371 | 0,00371 | 0,00373 | 0,00373 |
| 50 | 0,00358 | 0,00358 | 0,00335 | 0,00335 |
| 60 | --- | --- | 0,00333 | 0,00333 |
| 80 | --- | --- | 0,00325 | 0,00325 |
| 100 | --- | --- | 0,00316 | 0,00316 |
| 125 | --- | --- | 0,00314 | 0,00314 |

Interrupting capacity to EN 60934, CCC, UL 489, UL 1077

| IEC 60934 / CCC (3-pole) – test series E: | | | |
|---|-----------------|-------------------------|---------------------|
| voltage | number of poles | I _N max. (A) | I _{cn} (A) |
| DC 80 V | 1 + 2 | 0.02...125 | 10 000 |
| AC 240/415 V | 1 – 4 | 0.016...80 | 6 x I _N |
| AC 240 V | 1 | 0.016...20 | 5 000 |
| UL 489 – test sequence Z: | | | |
| voltage | number of poles | I _N max. (A) | I _{cn} (A) |
| DC 80 V | 1 + 2 | 0.5...125 | 10 000 |
| AC 120 V | 1 | 0.5...80 | 5 000 |
| AC 120/240 V | 1 (2) | 0.5...80 | 5 000 |
| AC 240 V | 1 | 0.5...20 | 5 000 |
| UL 1077: | | | |
| voltage | number of poles | I _N max. (A) | I _{cn} (A) |
| DC 80 V | 1 + 2 | 0.02...125 | 10 000 |
| AC 277/480 V | 1 – 4 | 0.02...70 | 5 000 |



Technical data

| | |
|--------------------------------------|---|
| Voltage rating | 3 AC 415 V; AC 277/480 V; AC 120/240 V; AC 240 V; DC 80 V (higher DC voltages to special order) |
| Current rating range | 0.02...125 A single and multipole higher ratings upon request |
| Auxiliary circuit | AC 240 V 6 A DC 28 V 3 A DC 65 V 1 A DC 80 V 0.5 A |
| Typical life | 10,000 operations at 1 x I _N |
| Ambient temperature | -40...+85 °C (-40...+185 °F) |
| Insulation co-ordination (IEC 60664) | 2.5 kV/2 reinforced insulation in operating area |
| Dielectric strength | operating area test voltage AC 3,000 V Line to Load test voltage AC 1,500 V pole to pole (2- and 3-pole) test voltage AC 1,500 V main to auxiliary circuit test voltage AC 3,000 V switching to trip circuit (version -X) test voltage AC 1,500 V |
| Insulation resistance | > 100 MΩ (DC 500 V) |
| Degree of protection (IEC 60529) | operating area IP40 terminal area IP00 |
| Vibration | mounting attitude 10 g (57-2000 Hz) ± 0,76 mm (10-57 Hz) toggle down: at 0.9 x I _N other mounting attitudes: 10 g at 1 x I _N with curves F1, F2: 10 g at 0.8 x I _N in all mounting attitudes (57-2000 Hz) ± 0.76 mm (10-57 Hz) to IEC 60068-2-6, test Fc 10 frequency cycles/axis |
| Shock | directions 1, 2, 3, 4, 5: 100 g (11 ms) at 1 x I _N , direction 6: 100 g (11 ms) at 0.8 x I _N , with curves F1, F2: 100 g (11 ms) at 0.8 x I _N to IEC 60068-2-27, test Ea |
| Corrosion | 96 hours at 5 % salt mist, to IEC 60068-2-11, test Ka |
| Humidity | 240 hours at 95 % RH, to IEC 60068-2-78, test Cab |
| Mass | approx. 90 - 120 g per pole depending on version |

Ordering information for EN 60934 and UL 1077

| | |
|---|--|
| Type No. | 8345 |
| Mounting | |
| B | flange mounting, with rectangular aperture with mounting nut 6-32UNC |
| C | flange mounting, with rectangular aperture with mounting nut M3 |
| F | flange mounting, with round aperture with mounting nut M3 |
| Configuration | |
| 0 | without barrier |
| 1 | with small barrier |
| 2 | with large barrier (requested for multipole AC applications) |
| Number of poles | |
| 1 | single pole protected |
| 2 | two pole protected |
| 3 | three pole protected |
| 4 | four pole protected |
| Actuator configuration | |
| A | all poles with standard toggle |
| B | reduced number of standard toggles |
| Z | without actuator |
| Terminal design | |
| P | blade terminals ≤ 35 A |
| R | round connectors 6 mm |
| U | stud terminals M6 ≤ 125 A |
| V | stud terminals 1/4-20UNC-3A ≤ 125 A |
| W | laminated round terminals ≤ 125 A |
| Terminal hardware | |
| 0 | without |
| 3 | with washer and nut |
| Characteristic curve *) | |
| Characteristic curve, instantaneous: | |
| F1 | DC (limited to ratings of 1 A to 50 A) |
| F2 | AC 60/50 Hz (limited to ratings of 1 A to 50 A) |
| Short delay: | |
| K1 | DC |
| K2 | AC |
| Medium delay: | |
| M1 | DC |
| M2 | AC 60/50 Hz |
| Long delay: | |
| T1 | DC |
| T2 | AC 60/50 Hz |
| Version | |
| D | standard |
| Colour configuration | |
| B1 | black actuator |
| Marking | |
| | front plate actuator base |
| B1 | without ON-OFF |
| B2 | I_N ON-OFF |
| B3 | I_{Nt} , characteristic curves ON-OFF |
| Rated voltage | |
| B | AC or ≤ 80 V DC |
| Current ratings | |
| | 0.02...125 A |
| | higher current ratings |
| | upon request |

8345 - C 0 1 A - U 3 M1 - D B1 B1 B - 60 A ordering example

Ordering information for auxiliary contact module

| | |
|-----------------------------------|--|
| Type number | X8345 |
| Module | S auxiliary contact module |
| Auxiliary contacts | |
| 01 | in all poles |
| 02 | in pole 1 only |
| Auxiliary contact version | |
| K | auxiliary contacts (symmetrical terminals) |
| Auxiliary contact function | |
| W1 | 1 changeover |
| Terminal design | |
| 02 | microswitch with blade terminals DIN 46244-A2.8-0.5 |
| M | mounted to base unit |

X8345 - S 01 K W1 02 M ordering example

Approvals

| Authority | Standard | Rated voltage | Current ratings |
|-----------|-------------------------|---|--|
| VDE | IEC / EN 60934 | AC 240/415 V AC 240 V DC 80 V | 0.016 A...80 A 0.016 A...80 A 0.02 A...125 A |
| UL | UL 1077 C22.2 No 235 | AC 277/480 V AC 277 V DC 80 V | 0.02 A...70 A 0.02 A...70 A 0.02 A...125 A |
| UL | UL 489 C22.2 No 5 | AC 120/240 V AC 240 V AC 120 V DC 80 V | 0.05 A...80 A (2 pole) 0.05 A...20 A (1 pole) 0.05 A...80 A (1 pole) 0.05 A...125 A (1+2 pole) |
| CQC | GB 17701 | AC 240/415 V AC 240 V DC 80 V DC 110 V | 0.02 A...80 A (3 pole) 0.02 A...80 A (1 + 2 pole) 0.02 A...125 A (1 + 2 pole) 0.05 A...125 A (1 + 2 pole) |

Remote trip coil available to special order.

*) Other characteristic curves upon request (e.g. pulse delayed, for high inrush currents or capacitive loads)

Note:
Move actuator of multipole devices slowly and smoothly into ON position to ensure reliable latch-on behaviour of all poles.

Dimensions

Mounting version B/C

Flange mounting rectangular aperture

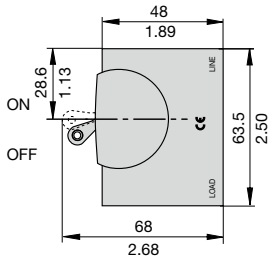

number of poles 1 to 4

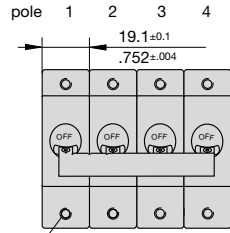

mounting thread M3 or 6-32
all dimensions referred to the top edge
mounting depth 4.2 mm/.165 in.
max. insertion depth 5.5 mm
max. tightening torque 0.33 Nm

Cut-out dimensions:

1-pole

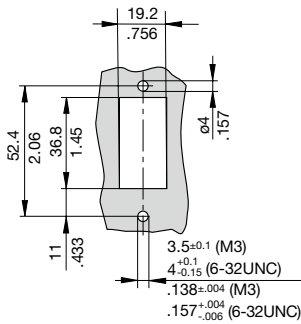

multipole

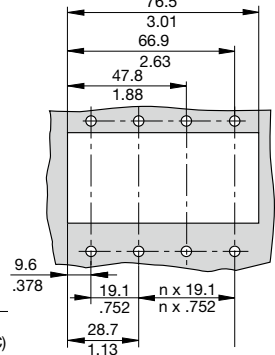

Mounting version F

Flange mounting round aperture

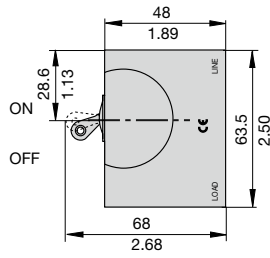

number of poles 1 to 4

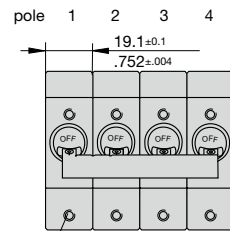

mounting thread M3 or 6-32
all dimensions referred to the top edge
mounting depth 4.2 mm/.165 in.
max. insertion depth 5.5 mm
max. tightening torque 0.33 Nm

Cut-out dimensions:

1-pole

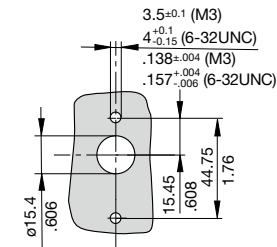

4-pole

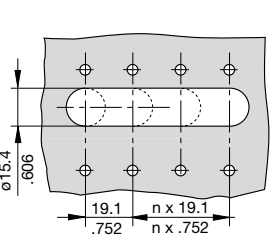

max. panel thickness: 3 mm

Installation drawing

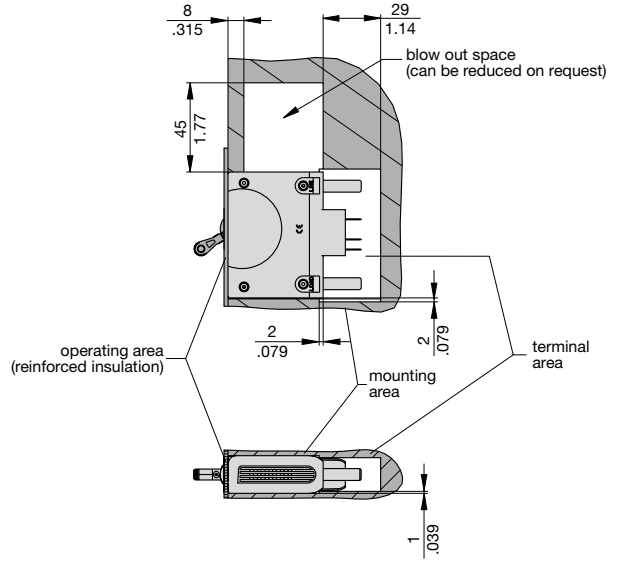

Terminal design / Dimensions

P - with blade terminals

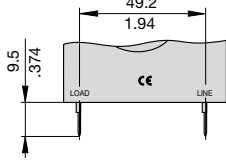

blade terminal A6.3-0.8 (QC .250) DIN 46244

R - round connectors
D = 6 mm

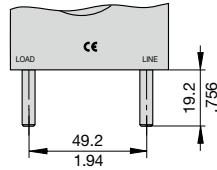

W - laminated round terminals

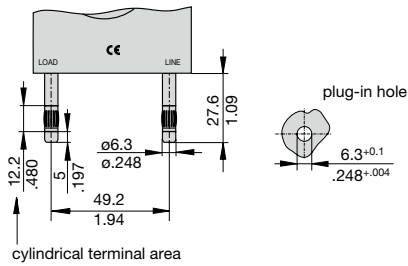

cylindrical terminal area

U/V stud terminals with auxiliary contacts

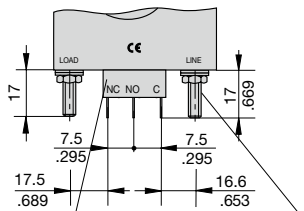

auxiliary contact module (change over)

tightening torque:
10-32 UNF. M5 max. 2 Nm
1/4-20 UNC. M6 max. 3 Nm

Internal connection diagrams

1-pole protected magnetically

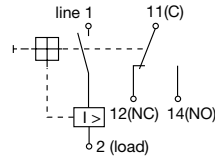

1-pole protected hydraulic-magnetically

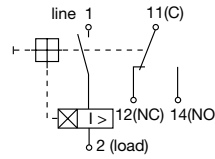

multipole

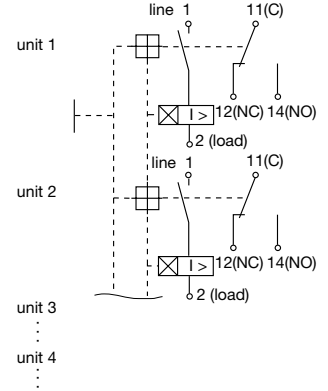

Typical time/current characteristics at +23 °C / +73.4 °F

1

Curve F1 (instantaneous) for DC

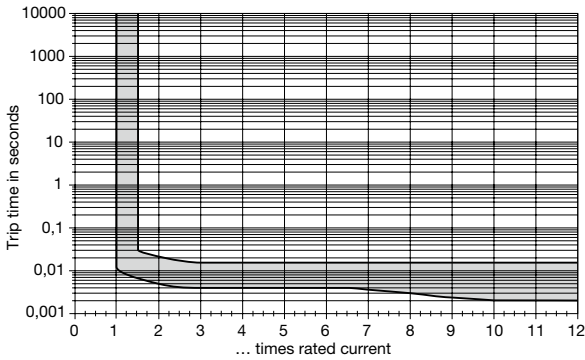

Curve F2 (instantaneous) for AC

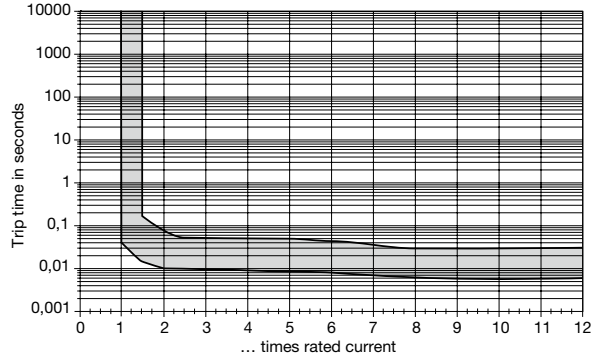

Curve K1 (short delay) for DC

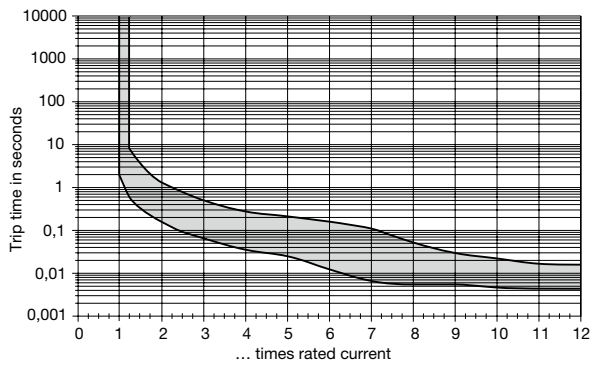

Curve K2 (short delay) for AC 50/60 Hz

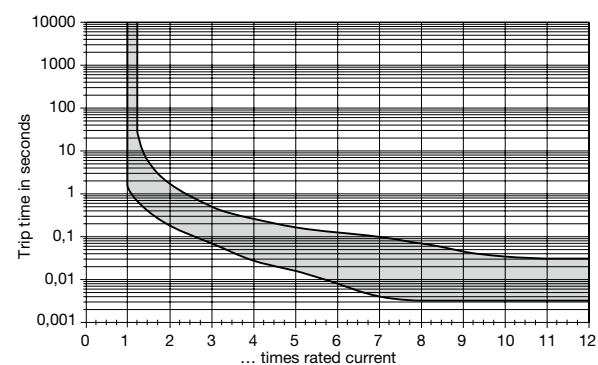

Curve M1 (medium delay) for DC

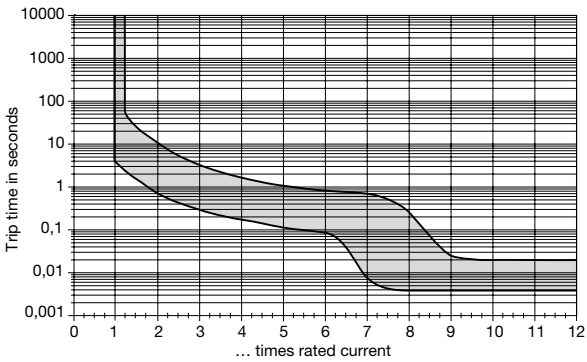

Curve M2 (medium delay) for AC 50/60 Hz

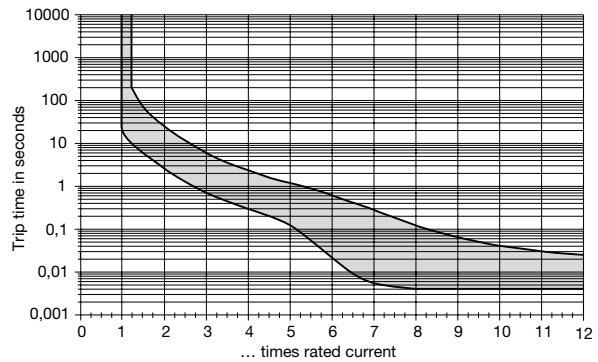

Curve T1 (long delay) for DC

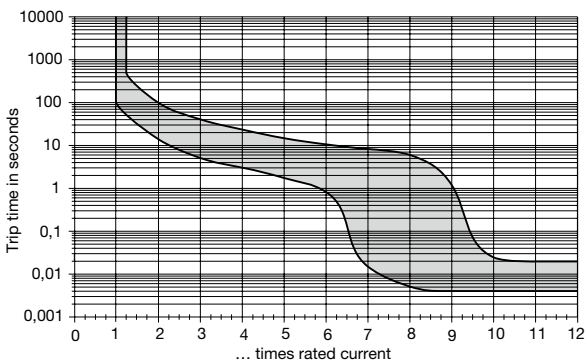

Curve T2 (long delay) for AC 50/60 Hz

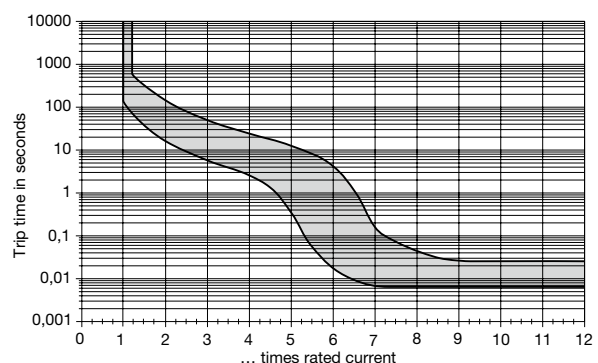

N.B. All curves will only be maintained if the escutcheon is mounted on a vertical surface. Ambient temperature or mounting side-by-side does not influence the trip curve, derating is not required. The breakers may trip in the event of current peaks < 0.003 sec. For these applications we offer a mechanical pulse delay – please enquire.
Other characteristic curves upon request (e.g. pulse delayed, for high inrush currents or capacitive loads).

Actuator configuration

A 1 toggle per pole, mounting version B/C

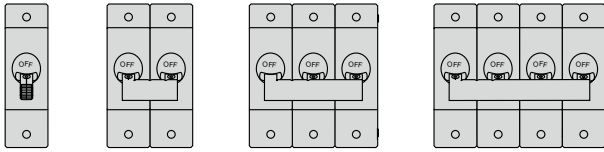

B reduced number of toggles per unit, mounting version B/C

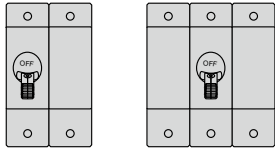

A 1 toggle per pole, mounting version F

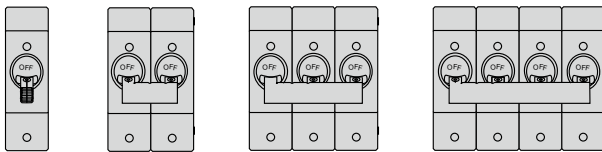

B reduced number of toggles per unit, mounting version F

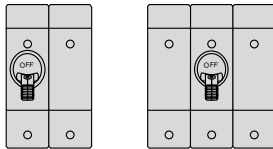

Z without toggles version B/C

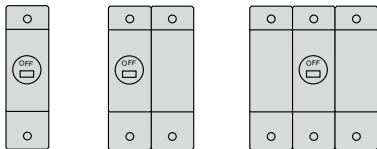

Z without toggles, mounting version F

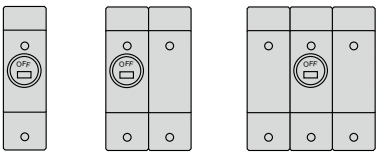

Interphase barriers / Dimensions

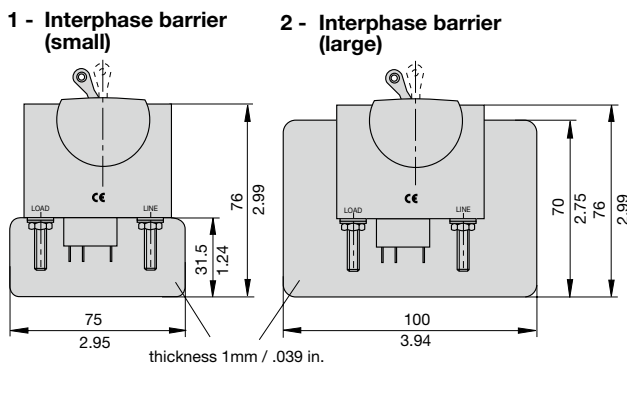

This is a metric design and millimeter dimensions take precedence (mm/inch)

Accessories

Splash cover (IP65) for 1-, 2-, 3-pole (only for mounting version B/C)

| | number of poles | mounting version | actuator configuration |
|--------------|-----------------|------------------|------------------------|
| X 222 444 01 | 1-pole | B | 1 |
| X 222 444 02 | 1-pole | C | 1 |
| X 222 444 11 | 2-pole | B | 2 |
| X 222 444 12 | 2-pole | C | 2 |
| X 222 444 21 | 3-pole | B | 3 |
| X 222 444 22 | 3-pole | C | 3 |

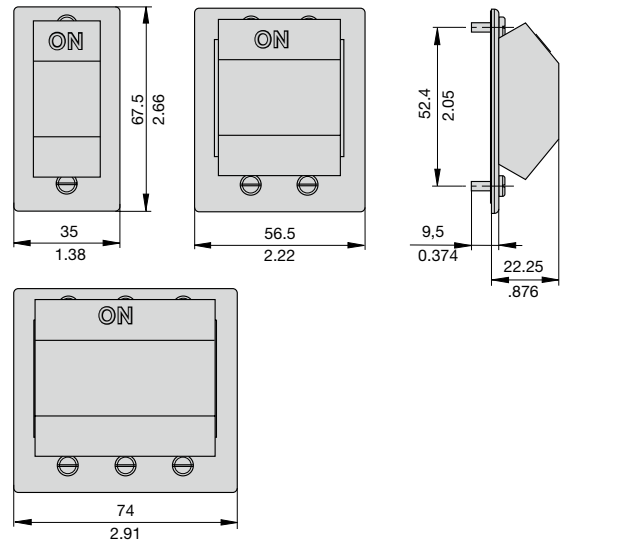

Toggle guard (only for mounting version B/C)
Y 307 381 01

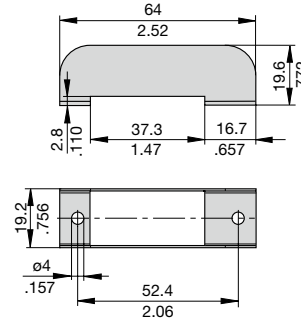

Shock directions

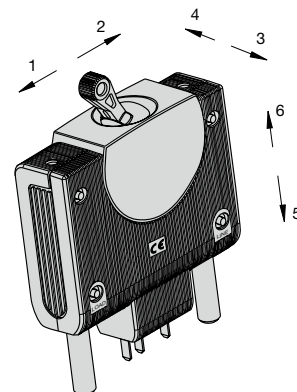

Description

A module which adds remote trip capability to all versions of type 8345. A voltage applied across the coil, by means of an external sensor for example, will cause disconnection of the main switch/circuit breaker mechanism.

Typical applications

Electrical monitoring of safety systems, remote trip.

Ordering information

| | |
|---|-----------------------------------|
| Type No. | |
| X8345 | Module for type 8345 |
| Module | |
| F | remote trip module |
| Assembly version | |
| 01 | only in pole 1 |
| 02 | only in pole 2 |
| Remote trip version | |
| X1 | DC |
| Voltage rating | |
| 12 | 12 V |
| 24 | 24 V |
| Terminal design | |
| 02 | blade terminals DIN 4644-A2.8-0.5 |
| M | module mounted to circuit breaker |
| X8345 - F 01 X1 12 02 M ordering example | |

Preferred types

Preferred types remote trip module:
 X8345-F-01-X1-12-02-M
 X8345-F-01-X1-24-02-M

Voltage ratings and typical internal resistance values

| Voltage rating | Internal resistance (Ω) |
|----------------|-------------------------|
| DC 12 V | 3.2 |
| DC 24 V | 14.6 |

This is a metric design and millimeter dimensions take precedence $\left(\frac{\text{mm}}{\text{inch}}\right)$

All dimensions without tolerances are for reference only. In the interest of improved design, performance and cost effectiveness the right to make changes in these specifications without notice is reserved. Product markings may not be exactly as the ordering codes. Errors and omissions excepted.

Dimensions

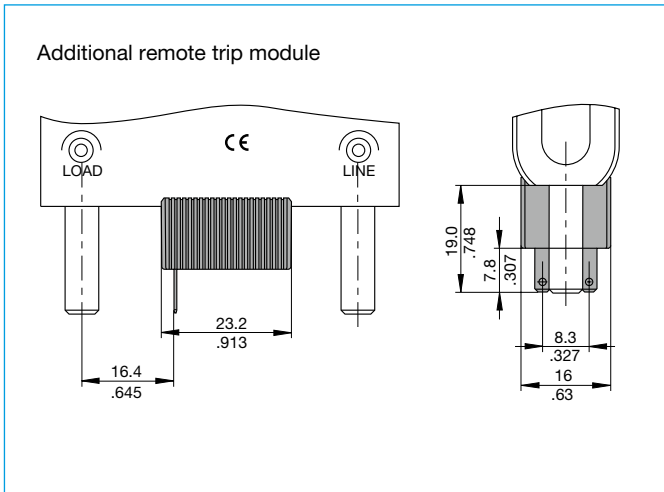

Internal connection diagram

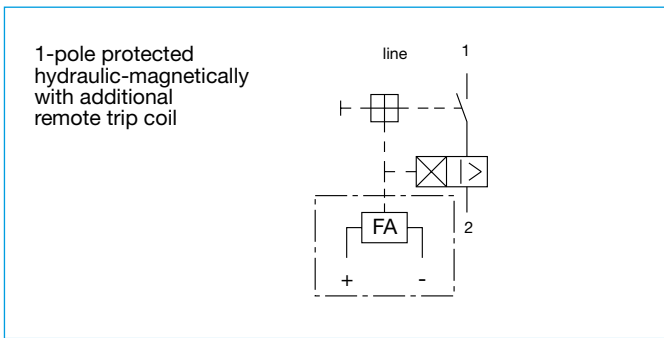

Technical data

| | |
|--|--|
| Voltage ratings | DC 12 V; DC 24 V |
| Power consumption | approx. 40 W |
| Pulse operation | 20 ms < t _{ON} < 100 ms/t _{OFF} > 10 sec (Continuous duty possible for multipole devices upon request) |
| Typical life | 10,000 operations at U _N |
| Ambient temperature | -40...+85 °C (-40...+185 °F) |
| Insulation co-ordination (IEC 60664) | 2.5 kV/2 (EN 60934) |
| Dielectric strength | test voltage |
| between main circuit and trip coil circuit | AC 3,000 V (EN 60934) |
| Insulation resistance | > 100 MΩ (DC 500 V) |
| Vibration | 6 g (57-2000 Hz) ± 0.46 mm (10-57 Hz) shock direction 1/2 4 g (57-2000 Hz) ± 0.30 mm (10-57 Hz) shock direction 3/4 3 g (57-2000 Hz) ± 0.23 mm (10-57 Hz) shock direction 5/6 to IEC 60068-2-6, test Fc 10 frequency cycles/axis |
| Shock | 100 g (11 ms) (not when mounted upside down) to IEC 60068-2-27, test Ea |
| Corrosion | 96 hours at 5 % salt mist, to IEC 60068-2-11, test Ka |
| Humidity | 240 hours at 95 % RH to IEC 60068-2-78, test Cab |
| Mass | approx. 8.5 g (without base unit) |

Description

The X8345-R is an additional module which provides remotely controlled ON and OFF functionality for the E-T-A series 8345 magnetic circuit breaker range. The module actuator, which is motor driven, is factory fitted adjacent to the circuit breaker(s) which it is controlling. The module can be operated by a suitable external changeover switch, momentary switches (one ON, one OFF). The status of the actuator will follow the position of the external switch, i.e. if the circuit breaker trips electrically or is operated manually, the actuator will not change.

A single module will control a single pole breaker or multipole circuit breakers up to 3 poles. In the application it has to be ensured that the supply voltage is maintained at all times.

When switching the circuit breaker OFF manually the module has also to be switched off by means of the changeover switch before switching the breaker on again. The same is true for normal switch-on of the breaker.

US patent number: US 7,532,095 B2

Ordering information

| Type number | |
|--------------------------------|--|
| X8345 | Module for type 8345, 1, 2 pole and 3 pole |
| Module | |
| R | remote ON/OFF actuation |
| Operating voltage | |
| 24 | DC 24 V |
| Add-on version | |
| 01 | mounted on right side |
| Mounting method | |
| 00 | front panel mounting (standard) |
| 02 | 2-bracket: module and circuit breaker fitted |
| Terminal design | |
| 01 | spring loaded screwless terminal 5-pin |
| Supply status | |
| M | module mounted to the base unit |
| X8345 - R 24 01 00 01 M | ordering example |

Technical data

| | |
|--------------------------------------|---|
| Voltage rating | DC 24 V (16...32 V) |
| ON duty | 50 % / 60 sec |
| Trip time | < 2 sec |
| Blocking current | < 1.5 A |
| Control current | < 3 mA |
| Typical life | 10,000 operations (ON/OFF) |
| Ambient temperature | -25...70 °C (-13...158 °F) |
| Insulation co-ordination (IEC 60664) | 2.5 kV/2 (EN 60934) |
| Dielectric strength pole to module | test voltage AC 1,500 V (EN 60934) |
| Insulation resistance | > 100 MΩ (DC 500 V) |
| Vibration | 10 g (57-2000 Hz), ± 0,76 mm (10-57 Hz) to IEC 60068-2-6, test Fc, 10 frequency cycles/axis |
| Shock | 100 g (11 ms) to IEC 60068-2-27, test Ea |
| Corrosion | 96 hours at 5 % salt mist, to IEC 60068-2-11, test Ka |
| Humidity | 240 hours at 95 % RH, to IEC 60068-2-78, test Cab |
| Mass | approx. 65 g (without base unit) |



X8345-R

Internal connection diagrams

single pole, hydraulic-magnetic protection, with remote ON/OFF actuation (operated by changeover switch)

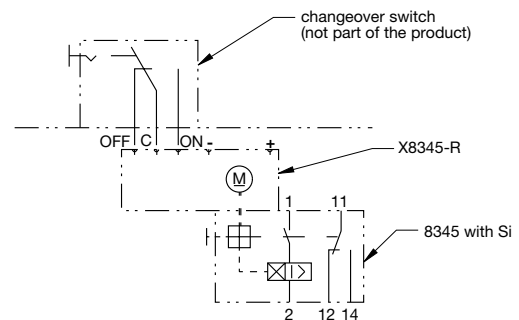

single pole, hydraulic-magnetic protection, with remote ON/OFF actuation (actuated by two momentary switches)

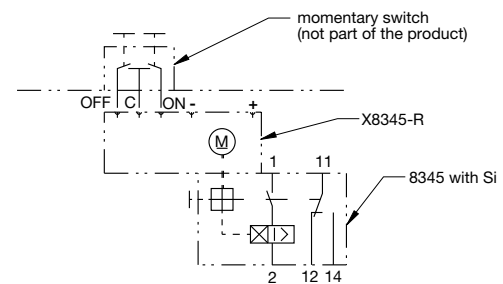

Typical applications

Remote circuit breaker control (ON/OFF) for communication systems, marine installations, automation equipment and similar requirements.

Caution:

During actuation of the remote control, free travel of the toggle must be ensured.

Dimensions

1

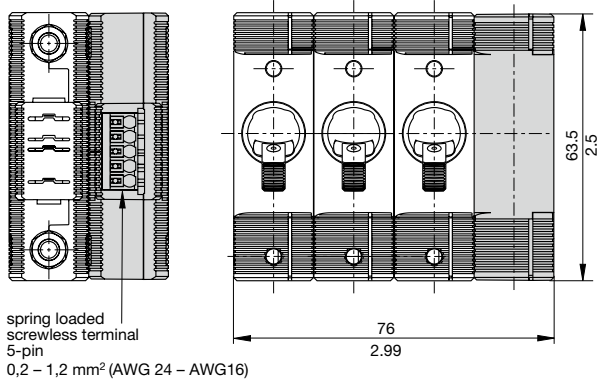
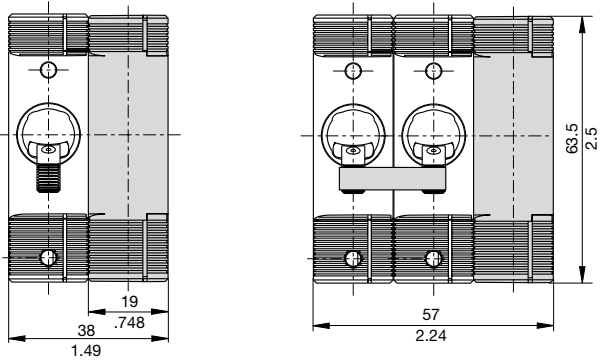

X8345-R-24-01-00-01-M

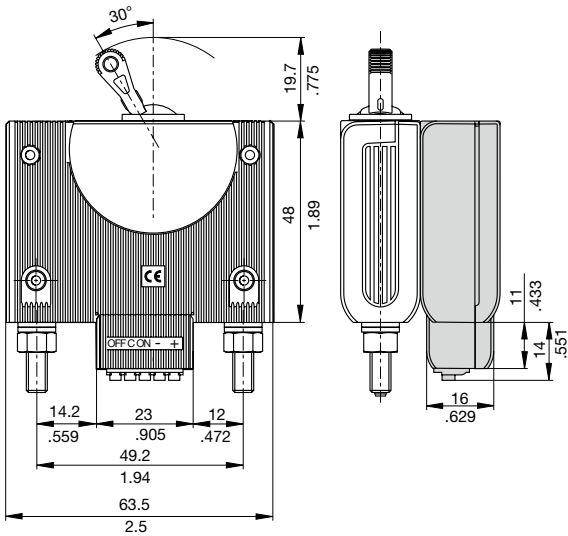

X8345-R-24-01-02-01-M

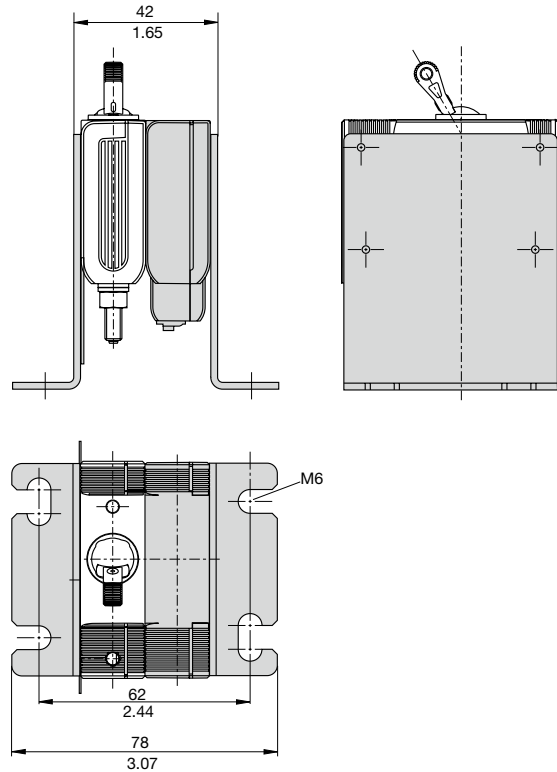

This is a metric design and millimeter dimensions take precedence (mm/inch)

All dimensions without tolerances are for reference only. In the interest of improved design, performance and cost effectiveness the right to make changes in these specifications without notice is reserved. Product markings may not be exactly as the ordering codes. Errors and omissions excepted.