

THIS DRAWING IS UNPUBLISHED. RELEASED FOR PUBLICATION
 © COPYRIGHT - By - ALL RIGHTS RESERVED.

LOC		DIST		REVISIONS			
P	LTR	DESCRIPTION	DATE	DWN	APVD		
W	REV PER ECO	13-019993	12-19-13	CT	KH		

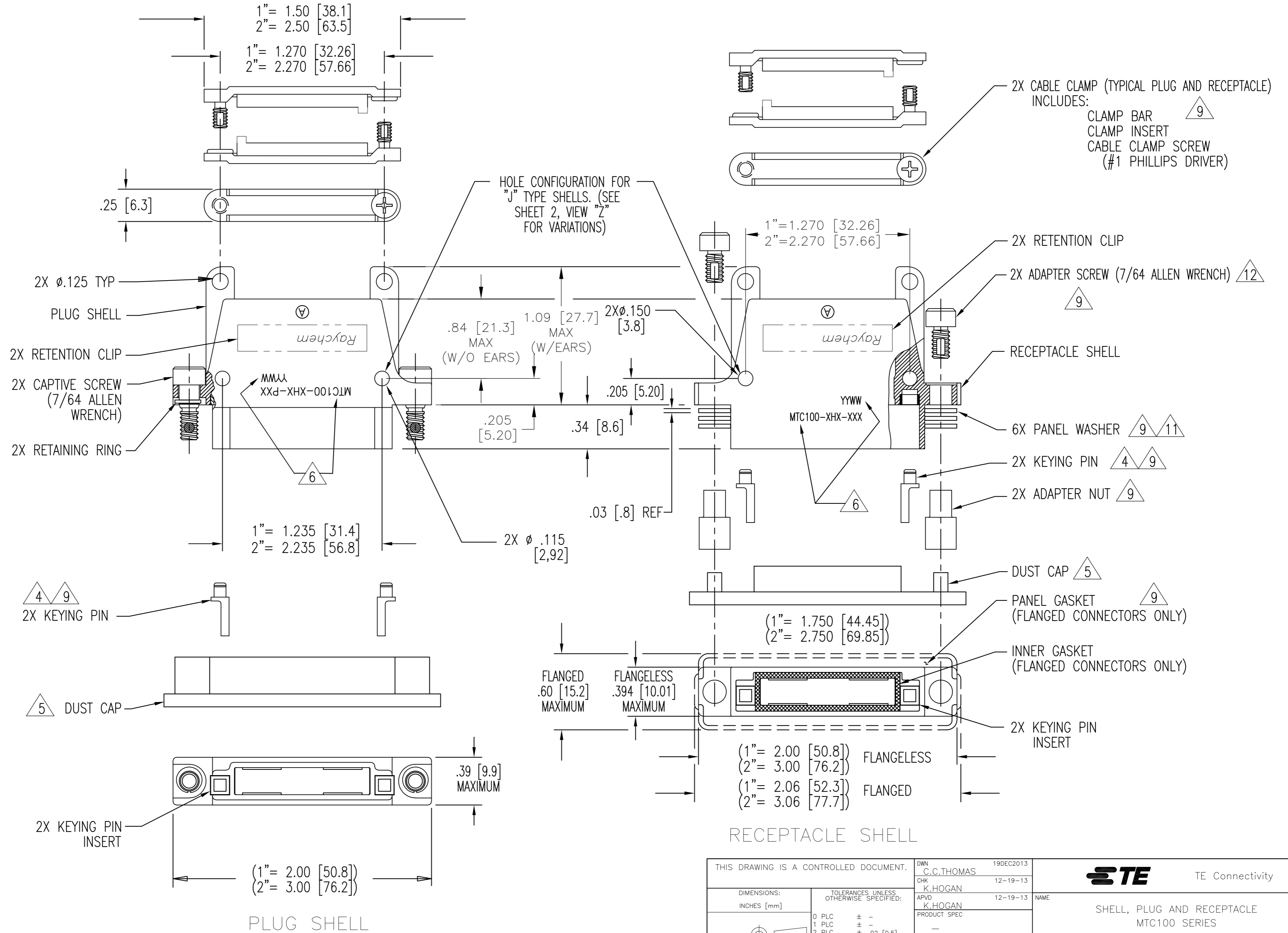

THIS DRAWING IS A CONTROLLED DOCUMENT.		DWN	19DEC2013	TE Connectivity	
		CHK	C.C.THOMAS		
		APVD	K.HOGAN		
		PRODUCT SPEC	K.HOGAN		
		APPLICATION SPEC			
		WEIGHT			
		CUSTOMER DRAWING			
DIMENSIONS: INCHES [mm]		TOLERANCES UNLESS OTHERWISE SPECIFIED:		NAME	
0 PLC ± -		1 PLC ± -		SIZE	
2 PLC ± .02 [0.5]		3 PLC ± .005 [0.13]		CAGE CODE	
4 PLC ± -		ANGLES ± -		DRAWING NO	
MATERIAL		FINISH		RESTRICTED TO	
				A2 00779	
				SCALE NTS	
				SHEET 1 of 3	
				REV W	

THIS DRAWING IS UNPUBLISHED. RELEASED FOR PUBLICATION
 © COPYRIGHT - By - ALL RIGHTS RESERVED.

LOC		DIST		REVISIONS			
P	LTR	DESCRIPTION	DATE	DWN	APVD		
-	-	SEE SHEET #1	-	-	-		

1. PART NUMBER VARIABLES: (NOT ALL POSSIBLE CONFIGURATIONS SHOWN ON THIS DRAWING ARE AVAILABLE AS STANDARD PRODUCTS. PLEASE CHECK WITH RAYCHEM TO CONFIRM AVAILABILITY.)
- MTC100-XHX-XXX-XXX
- MODIFICATIONS (see table I) (THIS SPACE BLANK IF NO MODIFICATION IS APPLICABLE)
 - 1= W/O CABLE CLAMP AND W/O EARS ON SHELL
 - 2= WITH CABLE CLAMP AND EARS ON SHELL
 - 3= W/O CABLE CLAMP AND WITH EARS
 - 4= WITH FLAT CABLE CLAMP (SEE VIEW V) AND EARS ON SHELL
 - 1= BLACK ANODIZED (WHITE MARKING)
 - 2= ELECTROLESS NICKEL (BLACK MARKING)
 - 3= CADMIUM OVER NICKEL UNDERPLATE (BLACK MARKING)
 - P= PLUG
 - R= FLANGELESS RECEPTACLE
 - F= FLANGED RECEPTACLE: STANDARD ("J" TYPE) HAS NON CONDUCTIVE FLUOROSILICONE GASKET SHIELDED ("S" TYPE) HAS CONDUCTIVE FLUOROSILICONE GASKET
 - 1= 1 INCH
 - 2= 2 INCH
 - J= STANDARD TYPE
 - S= SHIELDED
 - Y= SPECIAL TYPE: REFER TO INDIVIDUAL SPECIFICATION CONTROL DRAWINGS FOR DESCRIPTIONS

2. MATERIAL:
- A) SHELL ALUMINUM ALLOY PER ASTM B85
 - B) RETENTION CLIP COPPER ALLOY 172 PER ASTM B194
 - C) ADAPTER SCREW OR CAP SCREW STAINLESS STEEL PER SAE-AMS-QQ-S-763, 300 SERIES
 - D) ADAPTER NUT OR RETAINER BUSHING STAINLESS STEEL PER SAE-AMS-QQ-S-763, 300 SERIES
 - E) PANEL OR LOCK WASHER STAINLESS STEEL PER SAE-AMS-QQ-S-763 OR ASTM B240, 300 SERIES
 - F) KEYING PIN HIGH GRADE POLYARYLENE THERMOPLASTIC, MOLDED
 - G) KEY PINS INSERT HIGH GRADE POLYARYLENE THERMOPLASTIC, MOLDED
 - H) CLAMP BAR STAINLESS STEEL PER SAE-AMS-QQ-S-763, 300 SERIES
 - J) CLAMP INSERT SILICONE ELASTOMER PER MIL-R-25988
 - K) CAPTIVE SCREW STAINLESS STEEL PER SAE-AMS-QQ-S-763, 300 SERIES
 - L) RETAINING RING COPPER ALLOY 172 PER ASTM B194

3. FINISH:

	APPLIES TO NICKEL PLATED CONNECTORS	APPLIES TO CADMIUM PLATED CONNECTORS	APPLIES TO BLACK ANODIZED CONNECTORS
A) SHELL	NICKEL PLATED PER SAE-AMS-C-26074 CLASS 3, GRADE B	CADMIUM PLATED PER SAE-AMS-QQ-P-416 OVER NICKEL UNDERPLATE	BLACK ANODIZED PER MIL-A-8625, TYPE II, CLASS 2
B) RETENTION CLIP	NICKEL PLATED PER SAE-AMS-C-26074 CLASS 2, .00002 MINIMUM	CADMIUM PLATED PER SAE-AMS-QQ-P-416	NICKEL PLATED PER SAE-AMS-C-26074 CLASS 2, .00002 MINIMUM
C) ADAPTER OR CAP SCREW	PASSIVATED PER SAE-AMS-2700	CADMIUM PLATED PER SAE-AMS-QQ-P-416	PASSIVATED PER SAE-AMS-2700
D) ADAPTER NUT OR RETAINER BUSHING	PASSIVATED PER SAE-AMS-2700	CADMIUM PLATED PER SAE-AMS-QQ-P-416	PASSIVATED PER SAE-AMS-2700
E) PANEL OR LOCK WASHER	PASSIVATED PER SAE-AMS-2700	CADMIUM PLATED PER SAE-AMS-QQ-P-416	PASSIVATED PER SAE-AMS-2700
F) CLAMP BAR	PASSIVATED PER SAE-AMS-2700	CADMIUM PLATED PER SAE-AMS-QQ-P-416	PASSIVATED PER SAE-AMS-2700
G) CAPTIVE SCREW	PASSIVATED PER SAE-AMS-2700	CADMIUM PLATED PER SAE-AMS-QQ-P-416	PASSIVATED PER SAE-AMS-2700
H) RETAINING RING	NICKEL PLATED PER SAE-AMS-C-26074	CADMIUM PLATED PER SAE-AMS-QQ-P-416	NICKEL PLATED PER SAE-AMS-C-26074

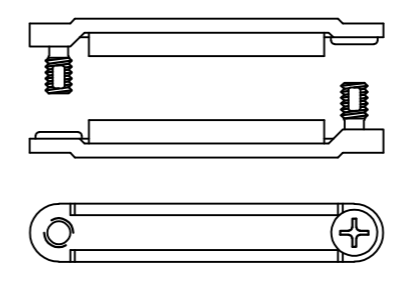

FLAT CABLE CLAMP
VIEW "V"

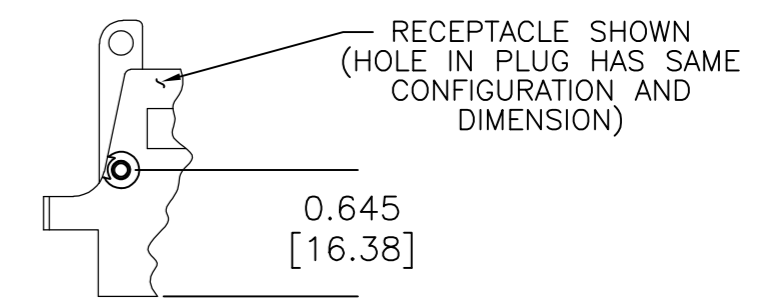

RECEPTACLE SHOWN (HOLE IN PLUG HAS SAME CONFIGURATION AND DIMENSION)
0.645 [16.38]
HOLE CONFIGURATION FOR ALL "S" TYPE SHELLS AND FLANGED "J" TYPE RECEPTACLE SHELLS
VIEW "Z"

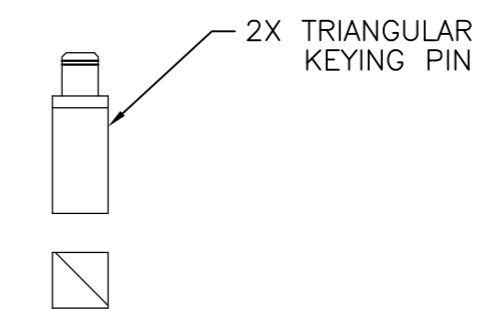

2X TRIANGULAR KEYING PIN
APPLIES TO -014 MODIFICATION (see table I)
VIEW "W"

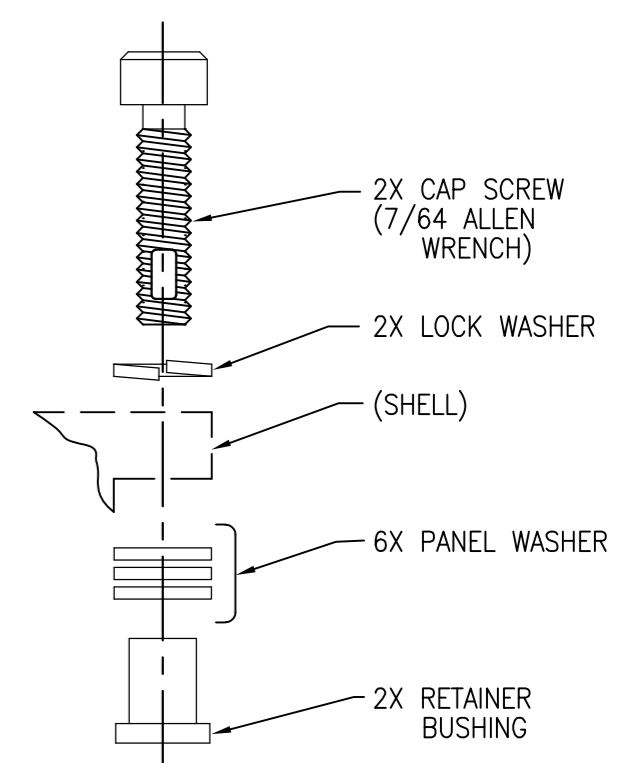

MTC50 HARDWARE APPLIES TO -020 MODIFICATION (see table I)
VIEW "Y"

TABLE III

PANEL THICKNESS	NUMBER OF PANEL WASHERS FOR EACH FASTENER
0.031/0.036 [0.8]/[0.9]	2
0.062/0.067 [1.5]/[1.7]	1
0.093/0.097 [2.3]/[2.4]	0

- 4. FOR MOUNTING / MATING AND KEYING INFORMATION, SEE RAYCHEM DRAWING D652-0012.
- 5. DUST CAP SUPPLIED WITH EACH PLUG OR RECEPTACLE. NO DUST CAPS ARE SUPPLIED WHEN SHELLS ARE SHIPPED TO CUSTOMER SPECIFICATION NUMBER 991006.
- 6. APPROPRIATE PART NUMBER AND DATE CODE ARE STAMPED APPROXIMATELY AS SHOWN.
- 7. THESE PARTS MEET THE REQUIREMENTS OF RAYCHEM SPECIFICATION C-6111.
- 8. FLANGED RECEPTACLE CONNECTORS PROPERLY MATED AND TORQUED TO 9 INCH POUNDS WILL EXHIBIT AN AIR LEAK RATE NOT EXCEEDING .5 CC / SECOND AT 30 PSI AND 25° C. (APPLICABLE ONLY TO FLANGED RECEPTACLES WITH PIN INSERTS)
- 9. THESE ITEMS ARE SUPPLIED UNASSEMBLED.
- 10. SEE TABLE II & TABLE 4 SHEET 3, WEIGHTS ARE WITHOUT DUST CAP.
- 11. THIS RECEPTACLE IS REAR PANEL MOUNTED BY REMOVING AS MANY PANEL WASHERS AS REQUIRED TO ACCOMMODATE THE THICKNESS OF THE PANEL BEING USED. (SEE TABLE III)
- 12. RECEPTACLE ADAPTER SCREWS (CAP SCREWS) ARE TO BE TORQUED TO 15±1 INCH-LBS (1.0±0.07 N-M)

TABLE I (MODIFICATIONS)

MODIFICATION DASH NUMBER	DESCRIPTION
-001	SAME AS STANDARD ASSEMBLY WITH EARS EXCEPT WITHOUT CABLE CLAMPS
-007	SAME AS STANDARD ASSEMBLY EXCEPT METAL PARTS ARE PLATED CADMIUM OVER NICKEL, SUPPLIED WITH MTC50 MOUNTING/ MATING HARDWARE (SEE VIEW "Y")
-014	SAME AS STANDARD EXCEPT ADDITIONALLY TRIANGULAR KEYING PINS INCLUDED (SEE VIEW "W")
-020	SAME AS STANDARD EXCEPT SUPPLIED WITH MTC50 MOUNTING/MATING HARDWARE (SEE VIEW "Y")
-028	SAME AS STANDARD ASSEMBLY EXCEPT SUPPLIED WITHOUT HARDWARE

THIS DRAWING IS A CONTROLLED DOCUMENT.

DWN	19DEC2013		TE Connectivity
CHK	C.C.THOMAS		
APVD	12-19-13		
NAME	K.HOGAN		
DIMENSIONS:	TOLERANCES UNLESS OTHERWISE SPECIFIED:	NAME	SHELL, PLUG AND RECEPTACLE MTC100 SERIES
INCHES [mm]	0 PLC ± -	PRODUCT SPEC	
	1 PLC ± -	APPLICATION SPEC	
	2 PLC ± .02 [0.5]		
	3 PLC ± .005 [0.13]		
	4 PLC ± -		
	ANGLES ± -		
MATERIAL	FINISH	WEIGHT	A2 00779 C=MTC100-XHX-XXX-XXX
		CUSTOMER DRAWING	SCALE NTS SHEET 2 of 3 REV W

THIS DRAWING IS UNPUBLISHED. RELEASED FOR PUBLICATION
 © COPYRIGHT - By - ALL RIGHTS RESERVED.

LOC		DIST		REVISIONS			
P	LTR	DESCRIPTION	DATE	DWN	APVD		
-	-	SEE SHEET #1	-	-	-		

THE FOLLOWING TABLE CONSISTS OF WEIGHTS FOR THESE SPECIFIC PART NUMBERS.

PART NUMBER	WEIGHT MAXIMUM GRAMS
MTC100-JH1-F32	30.8
MTC100-JH1-P32	23.8
MTC100-JH1-R32	27.3
MTC100-JH2-F32	43.7
MTC100-JH2-P32	34.2
MTC100-JH2-R32	38.3
MTC100-SH1-F33	24.2 *
MTC100-SH1-P33	16.1 *
MTC100-SH1-R33	20.3 *
MTC100-SH2-F33	32.3 *
MTC100-SH2-P33	22.7 *
MTC100-SH2-R33	27.0 *

PART NUMBER	WEIGHT MAXIMUM GRAMS
MTC100-JH1-F22	30.8
MTC100-JH1-P22	23.8
MTC100-JH1-R22	27.3
MTC100-JH2-F22	43.7
MTC100-JH2-P22	34.2
MTC100-JH2-R22	38.3
MTC100-SH1-F23	24.2 *
MTC100-SH1-P23	16.1 *
MTC100-SH1-R23	20.3 *
MTC100-SH2-F23	32.3 *
MTC100-SH2-P23	22.7 *
MTC100-SH2-R23	27.0 *

* = WEIGHT DOES NOT INCLUDE CABLE CLAMP

THIS DRAWING IS A CONTROLLED DOCUMENT.		DWN C.C.THOMAS 19DEC2013	 TE Connectivity	
DIMENSIONS: INCHES [mm]		CHK K.HOGAN 12-19-13		
TOLERANCES UNLESS OTHERWISE SPECIFIED: 0 PLC ± - 1 PLC ± - 2 PLC ± .02 [0.5] 3 PLC ± .005 [0.13] 4 PLC ± - ANGLES ± -		APVD K.HOGAN 12-19-13	NAME SHELL, PLUG AND RECEPTACLE MTC100 SERIES	
MATERIAL		PRODUCT SPEC	SIZE A2	CAGE CODE 00779
FINISH		APPLICATION SPEC	DRAWING NO MTC100-XHX-XXX-XXX	RESTRICTED TO
		WEIGHT -	SCALE NTS	SHEET 3 of 3
		CUSTOMER DRAWING	REV W	

MTC100-XHX-XXX-XXX