

THIS DRAWING IS UNPUBLISHED. RELEASED FOR PUBLICATION 20
 © COPYRIGHT 20 BY - ALL RIGHTS RESERVED.

REVISIONS					
P	LTR	DESCRIPTION	DATE	DWN	APVD
A1		ECR-16-004472	29MAR2016	BS	CW
A2		ECR-16-012130	24AUG2016	QY	CW
A3		ECR-16-013642	11NOV2016	BS	CW
A4		ECR-18-018974	03DEC2018	WOR	CW

TYPE-1: TOP ENTRY WITH ONE HOLE
 类型-1: 顶出一个孔

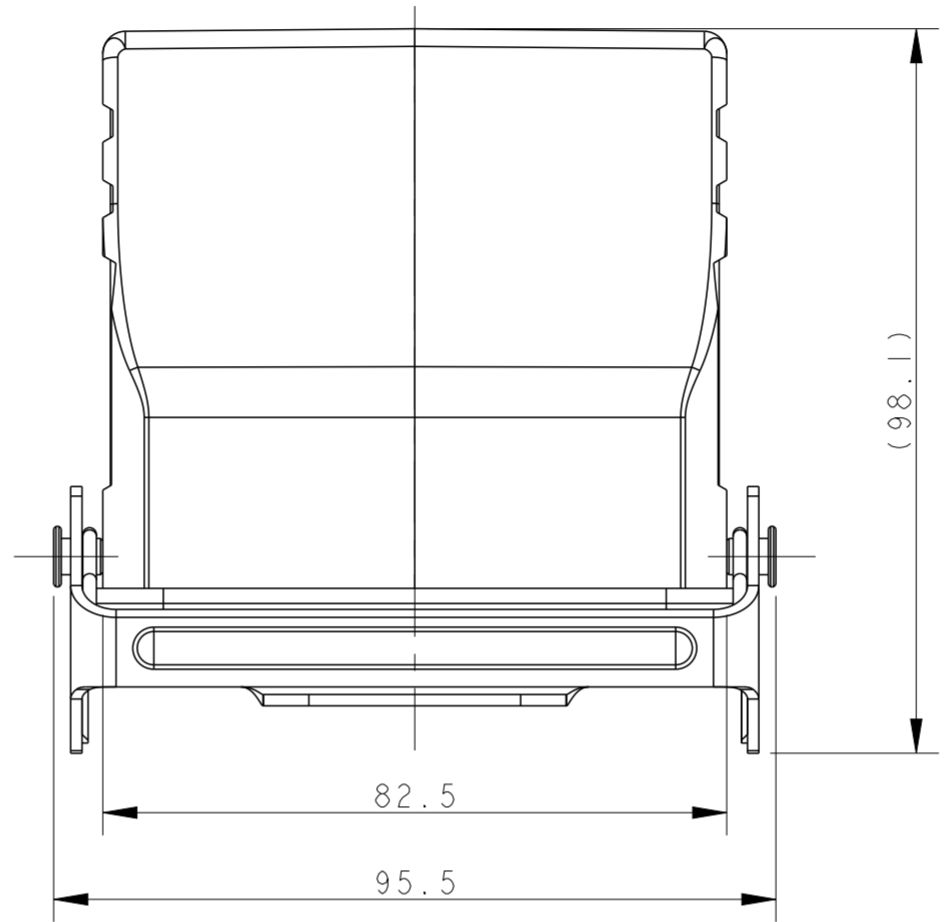
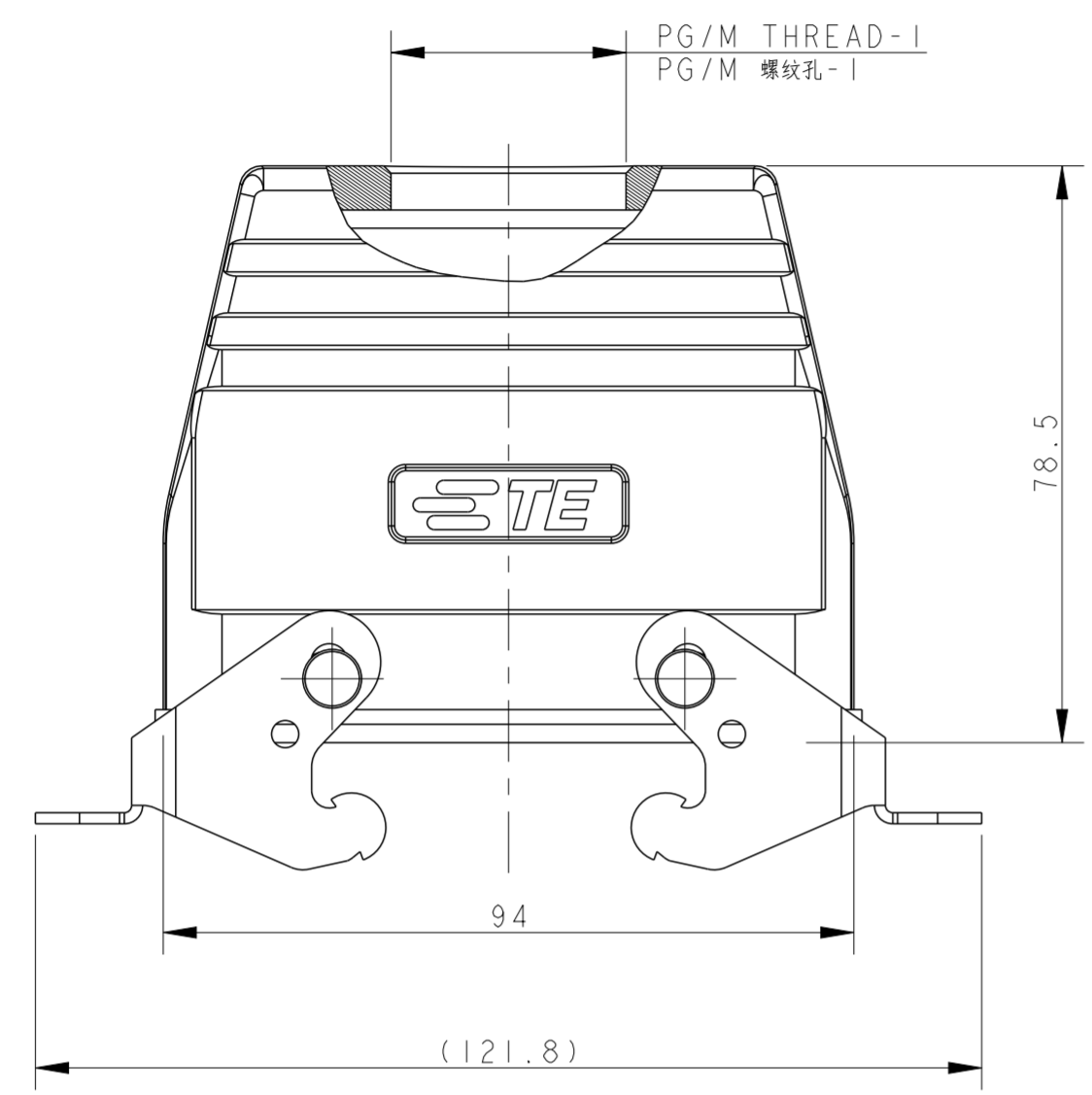

NOTES:
 1. TECHNICAL CHARACTERISTICS:
 BODY MATERIAL: DIE CAST ALUMINIUM ALLOY
 SURFACE TREATMENT: POWDER-COATED, GRAY
 DEGREE OF PROTECTION: IP65 (MATED)

注释:
 1. 技术参数:
 主体材料: 铝合金
 表面处理: 粉末喷涂, 灰色
 防护等级: IP65(配合)

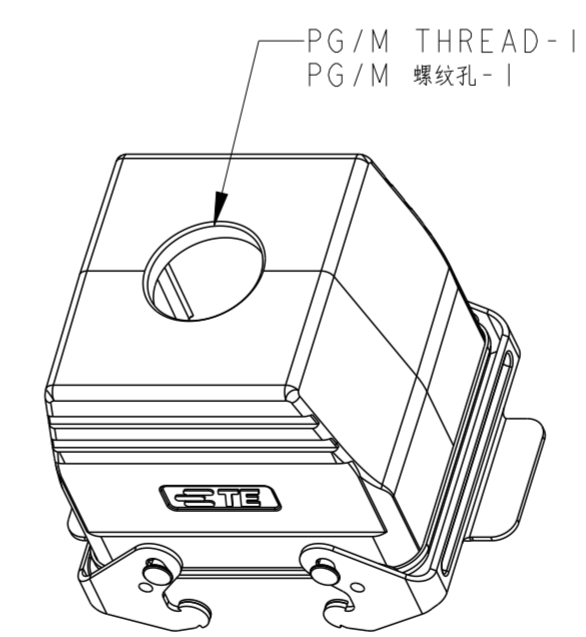
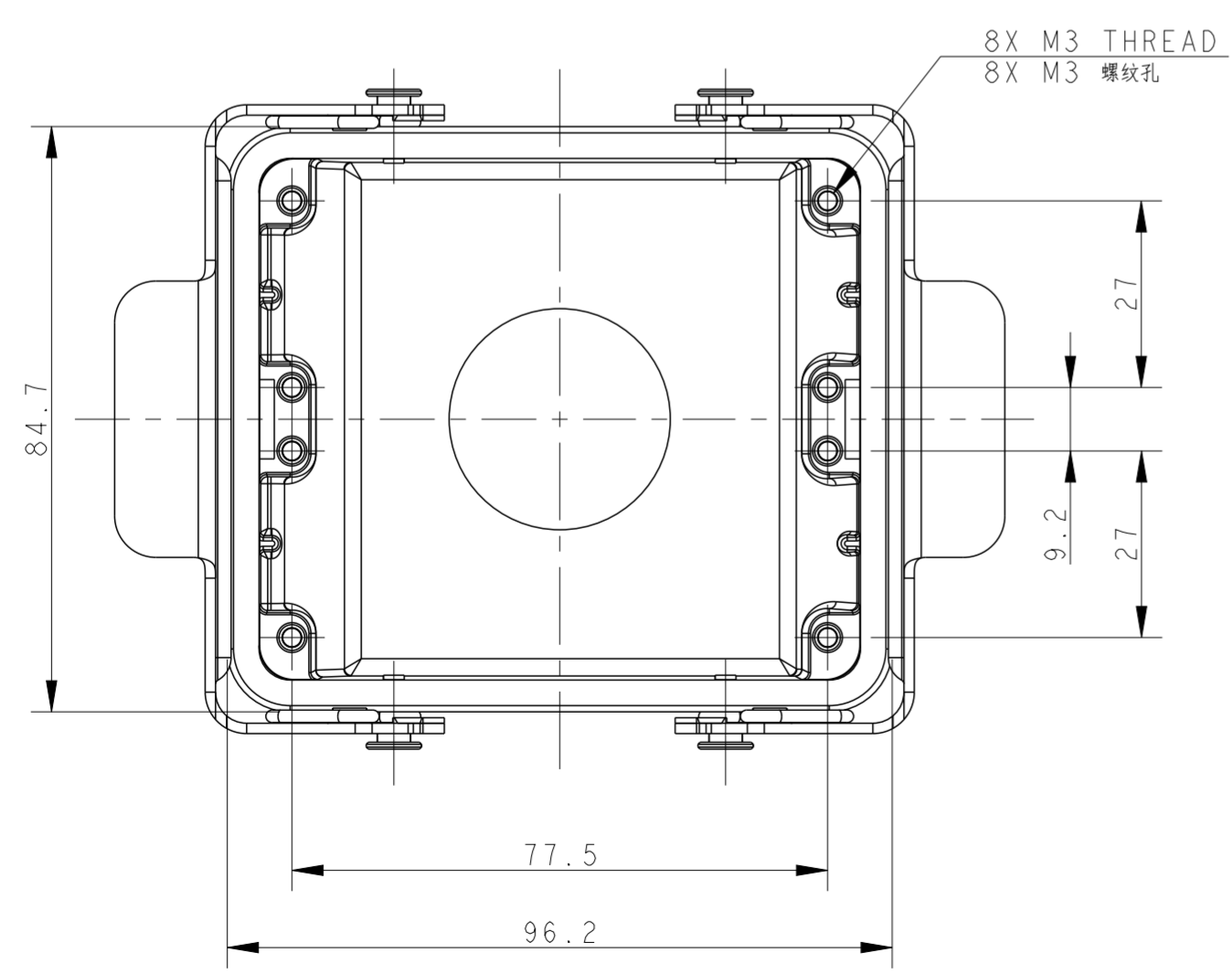

THIS DRAWING IS A CONTROLLED DOCUMENT.		DWN DAVID LI 04JUN2015	STE TE Connectivity	
DIMENSIONS: mm		CHK CHRIS WANG 04JUN2015		
TOLERANCES UNLESS OTHERWISE SPECIFIED:		APVD XU XIANG 04JUN2015	NAME H32B-TBF-PG/M	
0 PLC ±		PRODUCT SPEC 108-137013	SIZE A2	
1 PLC ±		APPLICATION SPEC 114-137013	CAGE CODE -	
2 PLC ±		WEIGHT -	DRAWING NO. C-T17103221XX000	
3 PLC ±		CUSTOMER DRAWING	RESTRICTED TO	
4 PLC ±			SCALE 1:1	
ANGLES ±			SHEET 1 OF 3	
FINISH -			REV A4	

THIS DRAWING IS UNPUBLISHED. RELEASED FOR PUBLICATION 20
 © COPYRIGHT 20 BY - ALL RIGHTS RESERVED.

REVISIONS				
P	LTR	DESCRIPTION	DATE	APVD
-	-	SEE SHEET 1	-	-

TYPE-2: TOP ENTRY WITH TWO HOLES
 类型-2: 顶出两个孔

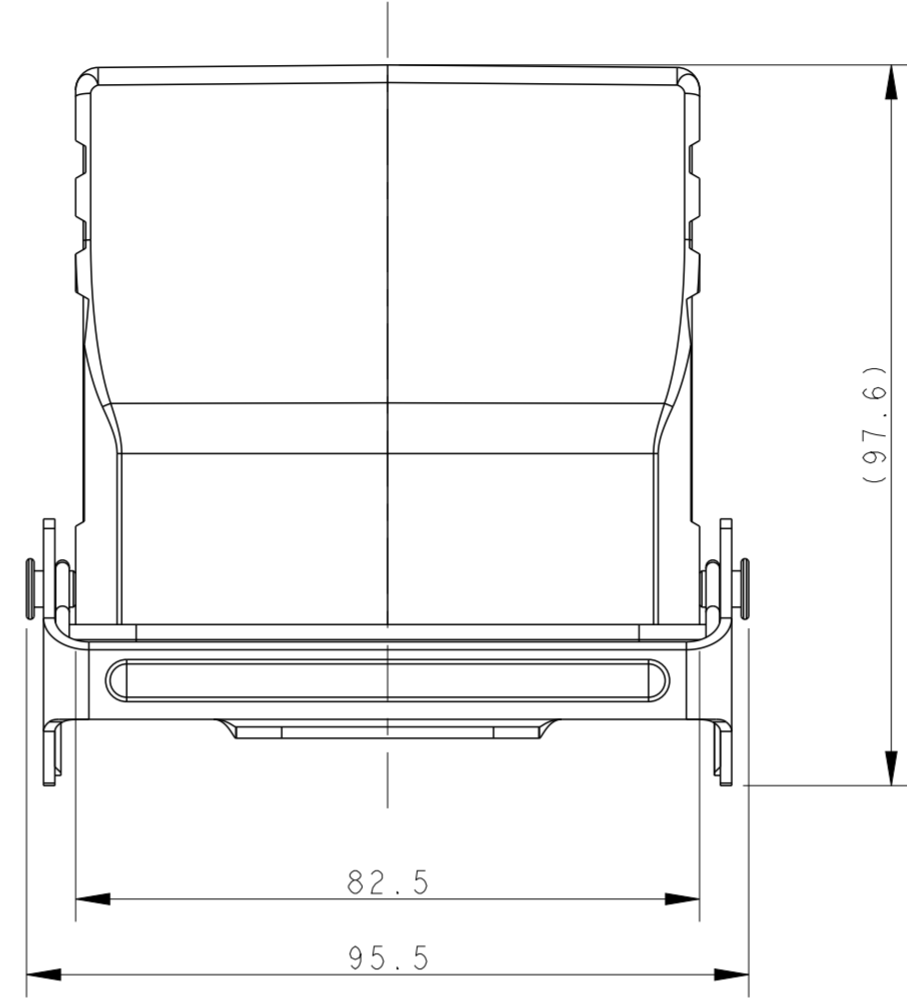
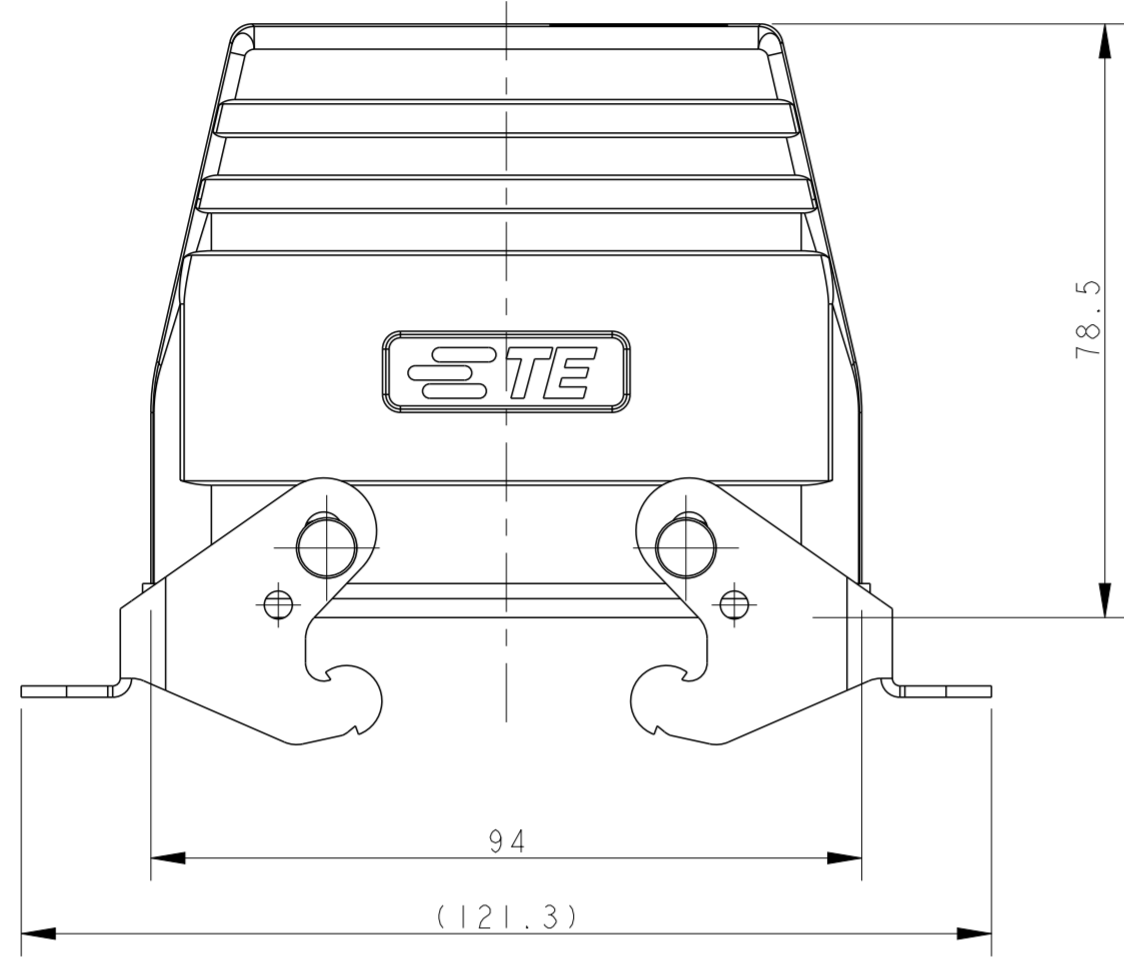

NOTES:
SEE SHEET 1

注释:
见表 1

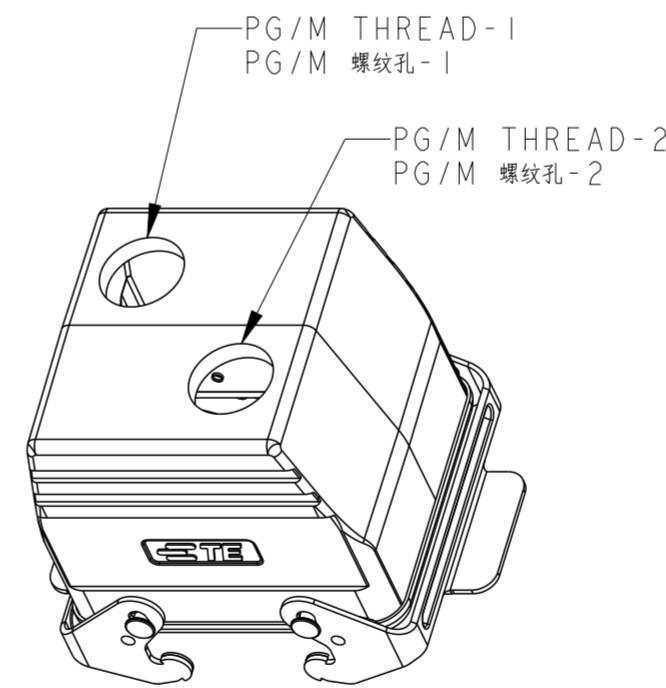
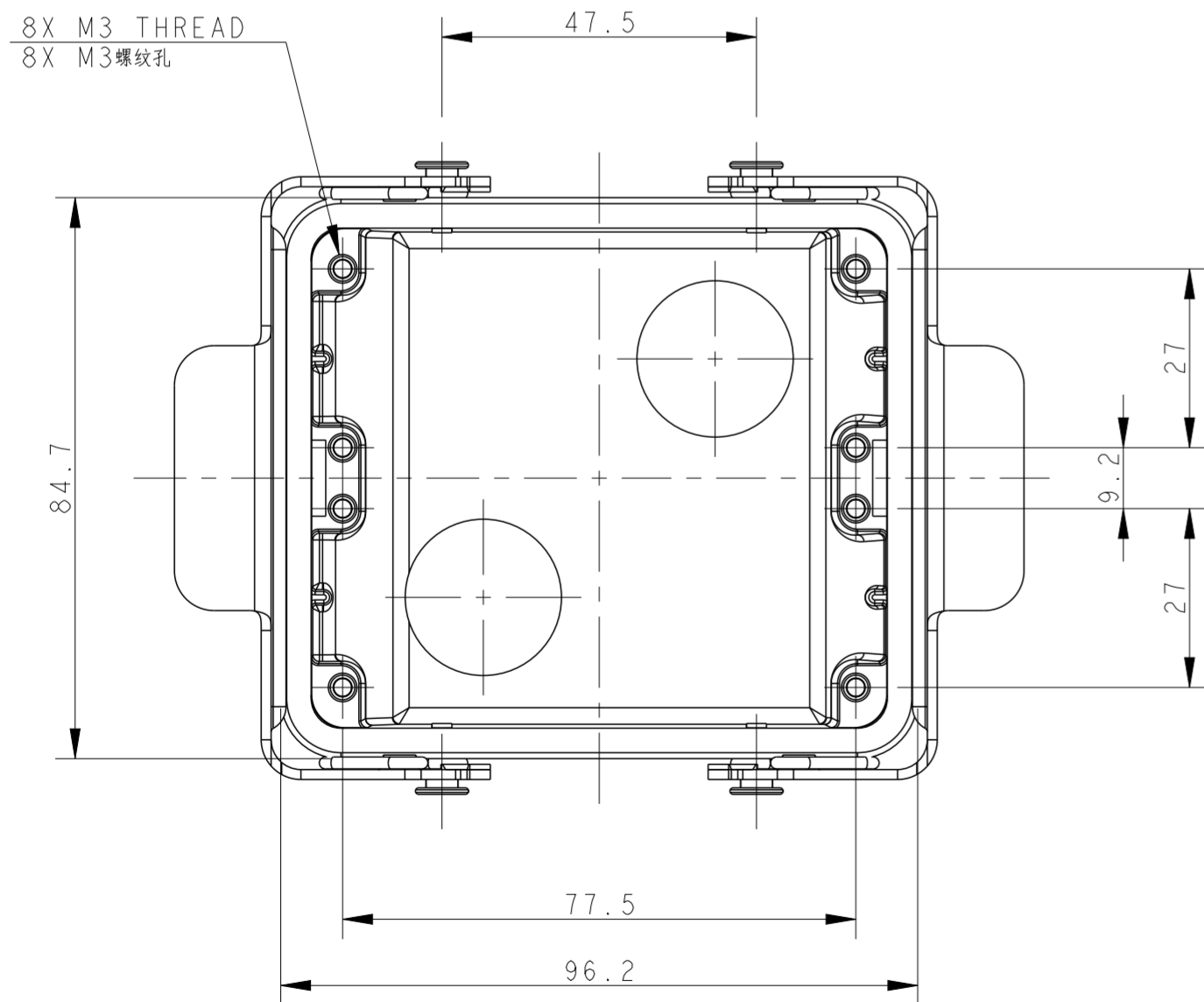

THIS DRAWING IS A CONTROLLED DOCUMENT.		DWN DAVID LI 04JUN2015	TE Connectivity	
DIMENSIONS: mm		CHK CHRIS WANG 04JUN2015		
TOLERANCES UNLESS OTHERWISE SPECIFIED:		APVD XU XIANG 04JUN2015	NAME H32B-TBF-PG/M	
0 PLC ±	1 PLC ±	PRODUCT SPEC 108-137013	SIZE A2	
2 PLC ±	3 PLC ±	APPLICATION SPEC 114-137013	CAGE CODE -	DRAWING NO. C-T17103221XX000
4 PLC ±	ANGLES ±	WEIGHT -	RESTRICTED TO	SCALE 1:1
FINISH -	FINISH -	CUSTOMER DRAWING	SHEET 2 OF 3	REV A4

THIS DRAWING IS UNPUBLISHED. RELEASED FOR PUBLICATION 20
 © COPYRIGHT 20 BY - ALL RIGHTS RESERVED.

REVISIONS					
P	LTR	DESCRIPTION	DATE	DWN	APVD
-		SEE SHEEL 1	-	-	-

NOTES:
SEE SHEET 1

注释:
见表 1

T1710322225-000	H32B-TBF-2M25	H32B HOUSING, CABLE-TO-CABLE, TOP ENTRY 2M25, METAL DOUBLE LOCKING, LOW CONSTRUCTION, POWDER COATED, GREY H32B下壳, 电缆对接, 顶出2M25, 彩锌双扣, 低结构, 灰色粉末喷涂	M25	M25	TYPE-2 类型-2
T1710322121-000	H32B-TBF-PG21	H32B HOUSING, CABLE-TO-CABLE, TOP ENTRY PG21, METAL DOUBLE LOCKING, LOW CONSTRUCTION, POWDER COATED, GREY H32B下壳, 电缆对接, 顶出PG21, 彩锌双扣, 低结构, 灰色粉末喷涂	PG21	-	TYPE-1 类型-1
T1710322129-000	H32B-TBF-PG29	H32B HOUSING, CABLE-TO-CABLE, TOP ENTRY PG29, METAL DOUBLE LOCKING, LOW CONSTRUCTION, POWDER COATED, GREY H32B下壳, 电缆对接, 顶出PG29, 彩锌双扣, 低结构, 灰色粉末喷涂	PG29	-	
T1710322132-000	H32B-TBF-M32	H32B HOUSING, CABLE-TO-CABLE, TOP ENTRY M32, METAL DOUBLE LOCKING, LOW CONSTRUCTION, POWDER COATED, GREY H32B下壳, 电缆对接, 顶出M32, 彩锌双扣, 低结构, 灰色粉末喷涂	M32	-	
T1710322136-000	H32B-TBF-PG36	H32B HOUSING, CABLE-TO-CABLE, TOP ENTRY PG36, METAL DOUBLE LOCKING, LOW CONSTRUCTION, POWDER COATED, GREY H32B下壳, 电缆对接, 顶出PG36, 彩锌双扣, 低结构, 灰色粉末喷涂	PG36	-	
T1710322140-000	H32B-TBF-M40	H32B HOUSING, CABLE-TO-CABLE, TOP ENTRY M40, METAL DOUBLE LOCKING, LOW CONSTRUCTION, POWDER COATED, GREY H32B下壳, 电缆对接, 顶出M40, 彩锌双扣, 低结构, 灰色粉末喷涂	M40	-	
T1710322134-000	H32B-TBF-G3/4	H32B HOUSING, CABLE-TO-CABLE, TOP ENTRY G3/4, METAL DOUBLE LOCKING, LOW CONSTRUCTION, POWDER COATED, GREY H32B下壳, 电缆对接, 顶出G3/4, 彩锌双扣, 低结构, 灰色粉末喷涂	G3/4	-	
T1710322150-000	H32B-TBF-M50	H32B HOUSING, CABLE-TO-CABLE, TOP ENTRY M50, METAL DOUBLE LOCKING, LOW CONSTRUCTION, POWDER COATED, GREY H32B下壳, 电缆对接, 顶出M50, 彩锌双扣, 低结构, 灰色粉末喷涂	M50	-	
PART NUMBER 料号	PART DESCRIPTION 描述		PG/M THREAD-1 PG/M 螺纹孔-1	PG/M THREAD-2 PG/M 螺纹孔-2	

THIS DRAWING IS A CONTROLLED DOCUMENT.		DWN DAVID LI 04JUN2015	 TE Connectivity	
		CHK CHRIS WANG 04JUN2015		
DIMENSIONS: mm		APVD XU XIANG 04JUN2015	NAME H32B-TBF-PG/M	
TOLERANCES UNLESS OTHERWISE SPECIFIED:		PRODUCT SPEC 108-137013	RESTRICTED TO	
0 PLC ±		APPLICATION SPEC 114-137013	SIZE A2	CAGE CODE -
1 PLC ±		WEIGHT -	DRAWING NO. ©-T17103221XX000	
2 PLC ±		CUSTOMER DRAWING		
3 PLC ±		SCALE 1:1		
4 PLC ±		SHEET 3 OF 3		
ANGLES ±		REV A4		
FINISH -				
MATERIAL -				