

# New Op Amp Ideas

National Semiconductor  
 Application Note 211  
 Robert J. Widlar  
 Robert C. Dobkin  
 Mineo Yamatake  
 December 1978



## Abstract

An op amp and voltage reference capable of single supply operation down to 1.1V is introduced. Performance is uncompromised and compares favorably with standard, state-of-the-art devices. In a departure from conventional approaches, the circuit can operate in a floating mode, powered by residual voltages, independent of fixed supplies. A brief description of the IC design is given, but emphasis is on applications. Examples are given for a variety of remote comparators and two-wire transmitters for analog signals. Regulator designs with outputs ranging from a fraction of a volt to several hundred volts are discussed. In general, greater precision is possible than with existing ICs. Designs for portable instruments are also looked into. These applications serve to emphasize the flexibility of the new part and can only be considered a starting point for new designs.

## Introduction

Integrated circuit operational amplifiers have reached a certain maturity in that there no longer seems to be a pressing demand for better performance. Devices are available at low cost for all but the most exacting needs. Of course, there is always room for improvement, but even substantial changes in specifications cannot be expected to cause much excitement.

A new approach to op amp design and application has been taken here. First, the amplifier has been equipped to function in a floating mode, independent of fixed supplies. This, however, in no way restricts conventional operation. Second, it has been combined with a voltage reference, since these two functions are often interlocked in equipment design. Third, the minimum operating voltage has been reduced to nearly one volt. It will be seen that these features open broad new areas of application.

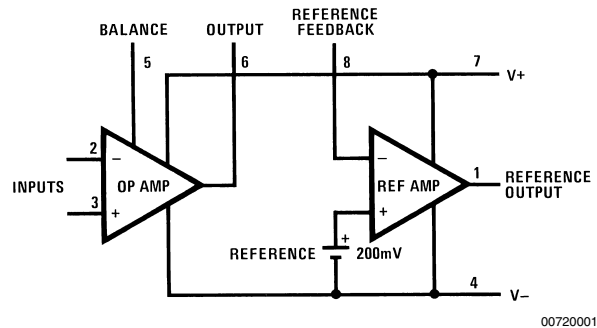

FIGURE 1. Functional diagram of the new IC

A functional diagram of the new device is shown in *Figure 1*. Even though a voltage reference and a reference amplifier have been added, it can still be supplied in an eight-pin TO-5 or mini-DIP. The pin connections for the op amp are the same as the industry standards. And offset balancing that tends to minimize drift has been provided. Both the op amp and the reference amplifier are internally compensated for unity-gain feedback.

*Table 1* shows that, except for bias current, the general specifications are much as good as the popular LM108. But the new circuit has a common mode range that includes  $V^-$  and the output swings within 50 mV of the supplies with 50  $\mu$ A load, or within 0.4V with 20 mA load. These parameters are specified in *Table 1* as the conditions under which gain and common-mode rejection are measured. *Table 2* indicates that the reference compares favorably with the better ICs on the market today.

TABLE 1. Typical Performance of the Operational Amplifier at 25°C

Parameter	Conditions	Value
Input Offset Voltage		0.3 mV
Offset Voltage Drift	$-55^{\circ}\text{C} \leq T_A \leq 125^{\circ}\text{C}$	2 $\mu\text{V}/^{\circ}\text{C}$
Input Offset Current		0.25 nA
Offset Current Drift	$-55^{\circ}\text{C} \leq T_A \leq 125^{\circ}\text{C}$	2 pA/ $^{\circ}\text{C}$
Input Bias Current		10 nA
Bias Current Drift	$-55^{\circ}\text{C} \leq T_A \leq 125^{\circ}\text{C}$	40 pA/ $^{\circ}\text{C}$
Common-Mode Rejection	$V^- \leq V_{\text{CM}} \leq V^+ - 0.85\text{V}$	102 dB
Supply-Voltage Rejection	$1.2\text{V} \leq V_S \leq 40\text{V}$	96 dB
Unloaded Voltage Gain	$V_S = \pm 20\text{V}$ , $V_O = \pm 19.95\text{V}$ , $I_O \leq 50 \mu\text{A}$	400V/mV
Loaded Voltage Gain	$V_S = \pm 20\text{V}$ , $V_O = \pm 19.6\text{V}$ ,	130V/mV

**TABLE 1. Typical Performance of the Operational Amplifier at 25°C (Continued)**

Parameter	Conditions	Value
	$R_L = 980\Omega$	
Unity-Gain Bandwidth	$1.2V \leq V_S \leq 40V$	0.3 MHz
Slew Rate	$1.2V \leq V_S \leq 40V$	0.15V/ $\mu$ s

**TABLE 2. Typical Performance of the Reference at 25°C**

Parameter	Conditions	Value
Line Regulation	$1.2V \leq V_S \leq 40V$	0.001%/V
Load Regulation	$0 \leq I_O \leq 1 \text{ mA}$	0.01%
Feedback Sense Voltage		200 mV
Temperature Drift	$-55^\circ\text{C} \leq T_A \leq 125^\circ\text{C}$	0.002%/°C
Feedback Bias Current		20 nA
Amplifier Gain	$0.2V \leq V_O \leq 35V$	75V/mV
Total Supply Current	$12.V \leq V_S \leq 40V$	270 $\mu$ A

Since worst-case internal dissipation can easily exceed 1W under overload conditions, thermal overload protection is included. Thus at higher ambient temperatures, this circuit is

better protected than conventional op amps with lesser output capabilities.

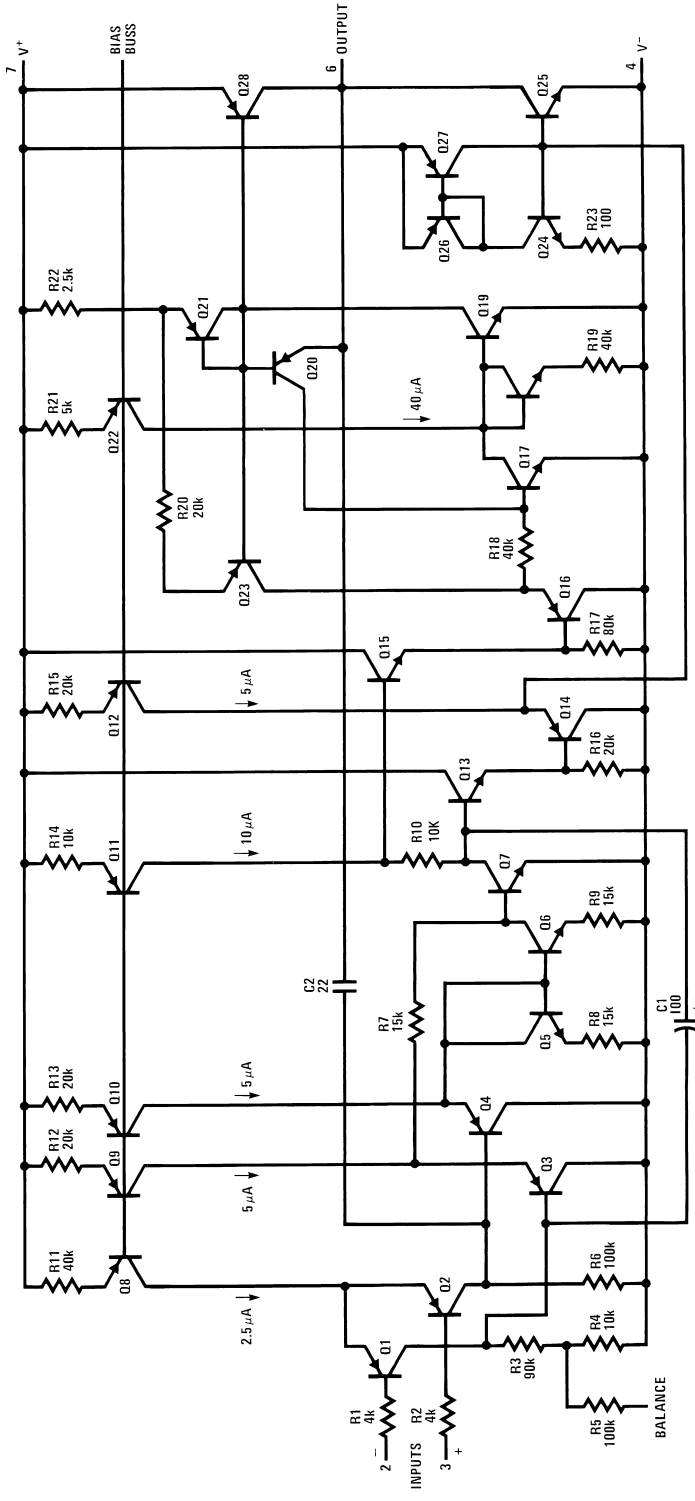

00720002

FIGURE 2. Essential details of the Op Amp

Figure 2 and Figure 5 are simplified schematics of the op amp, the reference and the internal current regulator. A complete circuit description is a subject in itself and is covered in detail elsewhere [1]. However, a brief run through the circuit is in order to give some understanding of the details that affect application.

## The Op Amp

Referring to Figure 2, lateral PNPs are used for the op amp input because this was the only reasonable way to get  $V^-$  included in the common-mode range while meeting the minimum-voltage requirement. These transistors typically have  $h_{FE} > 100$  at  $I_C = 1 \mu A$  and appear to match better than their NPN counterparts. Current gain is less affected by temperature, resulting in a fairly flat bias current over temperature (Figure 3). At elevated temperature the sharp decrease in bias current for  $V_{CM} > V^-$  is caused by the same substrate leakage that affects bi-FET op amps.

Protective resistors have been included in the input leads so that current does not become excessive when the inputs are forced below the negative supply, forward biasing the base tubs of the lateral PNPs.

Offset nulling is accomplished by connecting the balance terminal to a variable voltage derived from the reference output, as shown in Figure 4. Both the input stage collector voltage and the reference are well regulated and have a low temperature drift. The resistance of the adjustment potentiometer can be made very much lower than the resistance looking back into the balance pin. Therefore, no matching of temperature coefficients is required and offset nulling will tend to produce a minimum-drift condition.

With 200 mV on the balance control, the balance range is asymmetrical. Standard parts are trimmed to bring them into the  $-1$  mV to 8 mV adjustment range. Null sensitivity can be reduced for low-offset premium parts by adding a resistor on the top end of R1.

Proceeding through the circuit, the input stage is buffered by vertical PNP followers, Q3 and Q4. From here, the differential signal is converted to single ended and fed to the base of the second stage amplifier, Q7.

This configuration is not inherently balanced in that the emitter-base voltage of the PNP transistors is required to match that of the NPNs. The final design includes circuitry to correct for the expected variations.

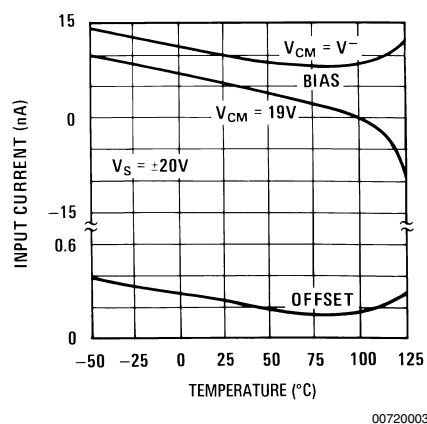

FIGURE 3. Variation of input current with temperature

From the collector of Q7, the signal splits, driving separate halves of the complementary class-B output stage. The NPN output transistor, Q25, is driven through Q13 and Q14.

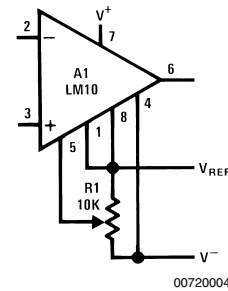

FIGURE 4. Op Amp offset adjustment

This complementary emitter follower arrangement provides the necessary current gain without requiring the extra bias voltage of the Darlington connection.

Base drive for the NPN output transistor is initially supplied by Q12, but a boost circuit has also been added to increase the available drive as a function of load current. This is accomplished by Q24 in conjunction with a current inverter.

Drive for the PNP half of the output is somewhat more complicated. Again, a compound buffer, Q15 and Q16, is used, although to maintain circuit balance rather than for current gain. The signal proceeds through two inverters, Q17 and Q19, to obtain the correct phase relationship and DC level shift before it is fed to the PNP output transistor, Q28.

This path has three common-emitter stages and, potentially, much higher gain than the NPN side. The gain is equalized, however, by the shunting action of Q18–R19 and Q21–R22 as well as negative feedback through Q23.

When the output PNP saturates, Q20 serves to limit its base overdrive with a feedback path to the base of Q17. As will be seen, Q20 is also important to floating-mode operation in that it disables the PNP drive circuitry when the op-amp output is shorted to  $V^+$ .

## The Reference

A simplified version of the reference circuitry and internal current regulator is shown in Figure 5. The design of the band-gap reference is unconventional both in its configuration and because it compensates for the second-order nonlinearities in the emitter-base voltage as well as those introduced by resistor drift. Thus, the bowed characteristic of conventional designs is eliminated, with better temperature stability resulting.

The reference element itself is formed by Q40 and Q41, with the output on the emitter of Q41. The  $V_{BE}$  component of the output is developed across R30, while the  $\Delta V_{BE}$  component is obtained by operating Q41 at a much lower current density than Q40. The output is made less sensitive to variations in biasing current by the action of R29. Curvature correction results from the different temperature coefficients of bias current for the two transistors.

The 200 mV reference voltage is fed to both the reference amplifier and the internal current regulator. The reference amplifier design is straight-forward, consisting of two stages with an emitter follower output. Unlike the op amp, the output can only swing within 0.8V of the positive supply. This should be kept in mind when designing low-voltage circuitry.

# The Reference (Continued)

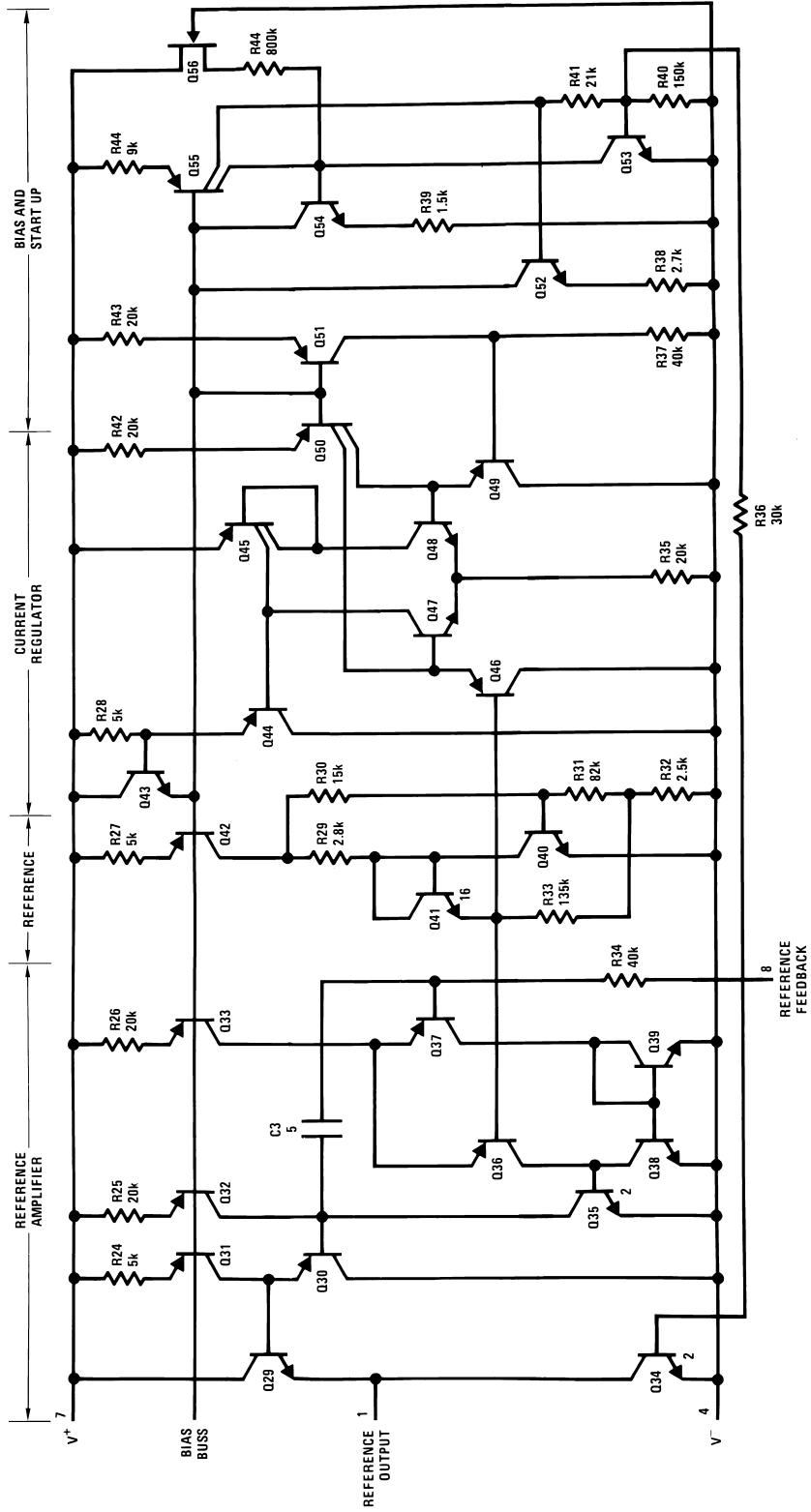

00720005

FIGURE 5. Simplified Schematic of the Reference and Internal Current Regulator

## The Reference (Continued)

A minimal sink current ( $\sim 20 \mu\text{A}$ ) is supplied by Q34. And since the reference is not included in the thermal protection control loop, conventional current limit is included on the final circuit to limit maximum output current to about 3 mA.

The current regulator is also relatively uncomplicated. A control loop drives the current source bias bus so that the output of one current source (Q51) is proportional to the reference voltage. The remaining current sources are slaved into regulation by virtue of matching.

The remaining circuitry generates a trickle current for start-up and biases internal circuitry.

An analysis of the complete circuit would serve only to bring into focus a multitude of detail such as second-order DC compensation terms, minor-loop frequency stabilization, clamps, overload protection, etc. Although necessary, these particulars tend to obscure the principles being put forward. So, having gained some insight into circuit operation, it is appropriate to proceed to some of the novel applications made possible with this new IC.

## Floating Comparators

The light-level detector in *Figure 6* illustrates floating-mode operation of the IC. Shorting the op-amp output to  $V^+$  disables the PNP half of the class-B output stage, as mentioned earlier. Thus, with a positive input signal, neither half of the output conducts and the current between the supply terminals is equal to the quiescent supply current. With negative input signals, the NPN portion of the output begins to turn on, reaching the short circuit current for a few hundred microvolts overdrive. This is shown in *Figure 7*.

*Figure 7* also shows the terminal characteristics for the case where the output is shorted to  $V^-$  so that only the PNP side can be activated. This mode of operation has not been so thoroughly investigated, but it gives a slightly lower ON voltage at moderate currents and the gain is generally higher below  $70^\circ\text{C}$ . With ON currents less than about 1 mA, the terminal voltage drops low enough to disrupt the internal regulators and the reference, producing some hysteresis. Further, there is a tendency to oscillate over about a  $50 \mu\text{V}$  range of input voltage in the linear region of comparator operation.

The above is not intended to preclude operation with the output connected to  $V^-$ , if there is a good reason for doing so. It is meant only to draw attention to the problems that might be encountered.

In *Figure 6*, the internal reference supplies the bias that determines the transition threshold. At crossover, the voltage across the photodiode is equal to the offset voltage of the op amp, so leakage is negligible. The circuit can directly drive such loads as logic circuits or silicon controlled rectifiers. The IC can be located remotely with the sensor, with the output transmitted along a twisted-pair line. Alternatively, a common ground can be used if there is sufficient noise immunity; and the signal can be transmitted on a single line.

It should be remembered that this particular design is fully compensated as a feedback amplifier. As such it is not particularly fast in comparator applications. With low-level

signals, delays a few hundred microseconds can be expected; and once in the linear region, the maximum change of terminal voltage is  $0.15/\mu\text{s}$ . This is illustrated in the plots of *Figure 8* and *Figure 9*. In general, high accuracy cannot be obtained with switch frequencies above 100 Hz.

Hysteresis can be provided as shown in *Figure 6* by feedback to the balance terminal. About 1 mV of hysteresis is obtained for a 5V output swing. However, this disappears near 10 Hz operating frequency because of gain loss.

*Figure 10* shows a flame detector that can drive digital circuitry directly. The platinum-rhodium thermocouple gives an 8 mV output at  $800^\circ\text{C}$ . This threshold is established by connecting the balance pin to the reference output.

## Linear Operation

The IC can also operate linearly in the floating mode. The simplest examples of this are the shunt voltage regulator in *Figure 11* and the current regulator in *Figure 12*. The voltage regulator is straightforward, but the current regulator is a bit unusual in that the supply current of the IC flows through the sense resistor and does not affect accuracy as long as it is less than the desired output current.

It is also possible to use remote amplifiers with two-wire signal transmission, as was done with the comparators. Remote sensors can be particularly troublesome when low-level analog signals are involved. Transmission problems include induced noise, ground currents, shunting from cable capacitance, resistance drops and thermoelectric potentials. These problems can be largely eliminated by amplifying the signal at the source and altering impedances to levels more suitable for transmission.

*Figure 13* is an example of a remote amplifier. It boosts the output of a high-impedance crystal transducer and provides a low impedance output. No extra wires are needed because DC power is fed in on the signal line.

*Figure 14* is a remote signal conditioner that operates in the current mode. A modification of the current source in *Figure 12*, it delivers an output current inversely proportional to sensor resistance. The output can be transmitted over a twisted pair for maximum noise immunity or over a single line with common ground if the signal is slow enough that sufficient noise bypass can be put on the line.

A current-mode signal conditioner for a thermocouple is shown in *Figure 15*. A thermocouple is in reality a two-junction affair that measures temperature differential. Absolute temperature measurements are made by controlling the temperature of one junction, usually by immersing it in an ice bath. This complication can be avoided with cold-junction compensation, which is an absolute thermometer that measures cold-junction temperature and corrects for any deviation from the calibration temperature.

In *Figure 15*, the IC temperature sensor (S1) generates an output proportional to absolute temperature. This current flows through R2, which is chosen so that its voltage drop has the same temperature coefficient as the thermocouple. Thus, changes in cold-junction temperature will not affect calibration as long as it is at the same temperature as S1.

Linear Operation (Continued)

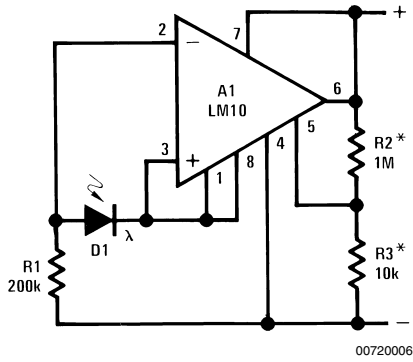

\*provides hysteresis

FIGURE 6. Two Terminal Light-Level Detector with Hysteresis

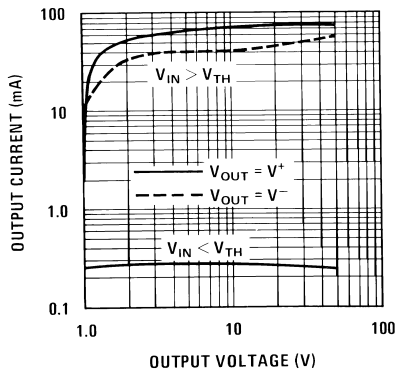

00720007

FIGURE 7. Terminal Characteristics Above and Below Threshold

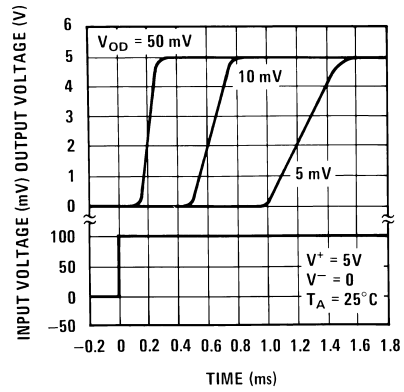

00720008

FIGURE 8. Comparator Response Times for Various Input Overdrives

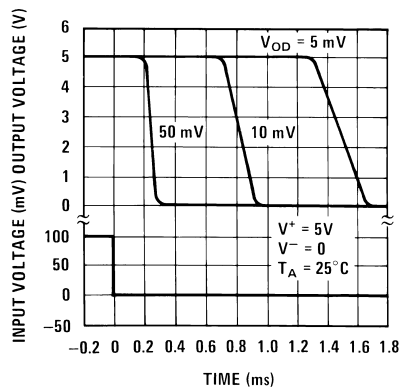

00720009

FIGURE 9. Comparator Response Times for Various Input Overdrives

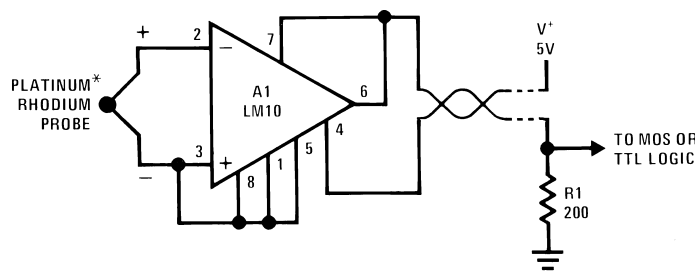

00720010

\*800 C threshold is established by connecting balance to V<sub>REF</sub>.

FIGURE 10. Flame Detector

Linear Operation (Continued)

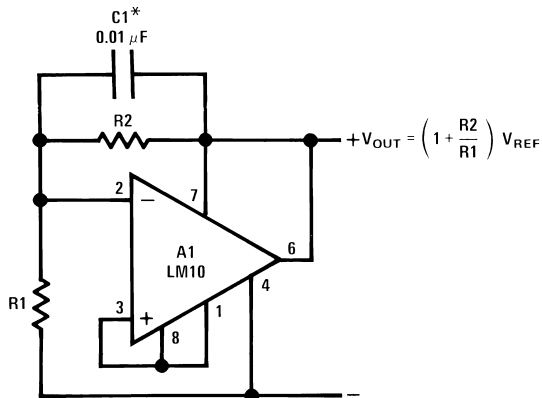

\*required for capacitive loading

00720011

FIGURE 11. Shunt Voltage Regulator

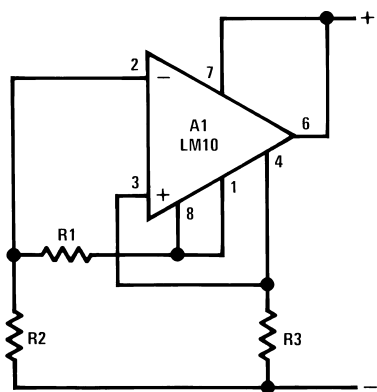

00720012

$$I_{OUT} = \frac{(R2 + R3) V_{REF}}{R1 R3}$$

FIGURE 12. Current Regulator

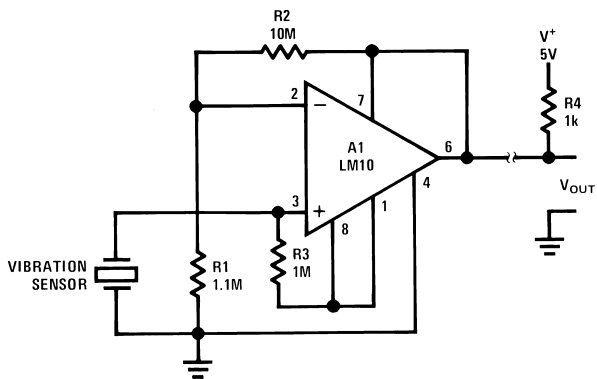

00720013

FIGURE 13. Remote Amplifier

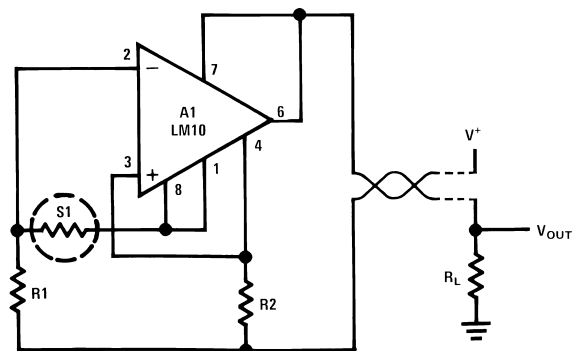

00720014

FIGURE 14. Two-Wire Transmitter for Variable-resistance Sensor

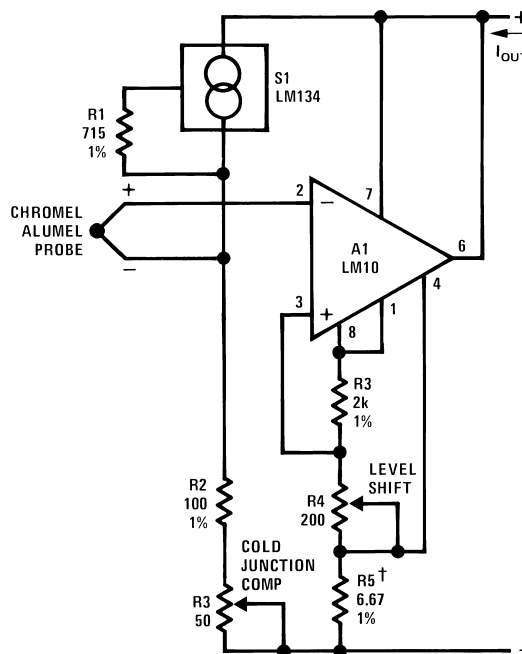

00720015

200°C ≤ T<sub>p</sub> ≤ 700°C  
1 mA ≤ I<sub>OUT</sub> ≤ 5 mA  
†gain trim

FIGURE 15. Current Transmitter for Thermocouple Including Cold Junction Compensation

In addition to powering S1, the reference is used to generate an offset voltage such that the output current is within operating limits for temperatures of interest. It is important that the reference be stable because drift will show up as signal. The indicated output-current range was chosen because it is one of the standards for two-wire transmission. With the new IC, the dynamic range can be increased by a factor of five in some cases (0.8 mA–20 mA) because the supply current is low. This could be used to advantage with a unidirectional signal where zero must be preserved: the less the offset required to put zero on scale, the less the offset-drift error.



## Linear Operation (Continued)

The circuit in *Figure 16* is the same thermocouple amplifier operating in the voltage mode. The output voltage range was chosen arbitrarily in that there are no set standards for voltage-mode transmission.

The choice between voltage- and current-mode operation will depend on the peculiarities of the application, although current mode seems to be favored overall. If there is sufficient supply voltage, the dynamic range of both approaches is about equal, provided the transmitter is capable of working at both low voltage and current. This situation could be modified by the voltage and current requirements of the sensor or conditioning circuitry.

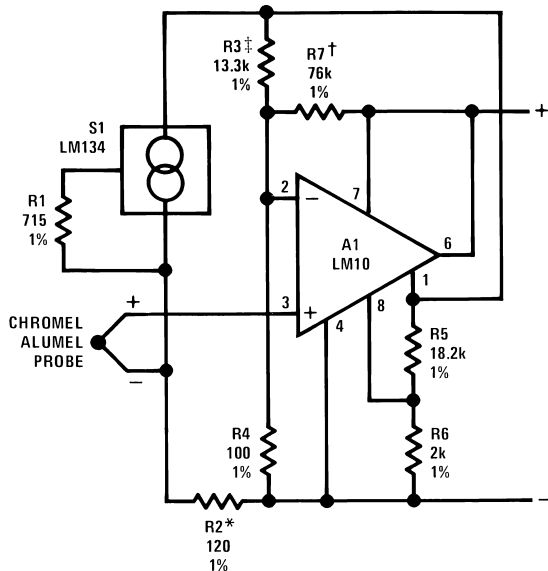

00720016

$$4V \leq V_{OUT} \leq 20V$$

$$200^{\circ}C \leq T_p \leq 700^{\circ}C$$

†span trim

‡level-shift trim

\*cold-junction trim

**FIGURE 16. Voltage Transmitter for Thermocouple, Including Cold Junction Compensation**

With voltage-mode operation, the line resistance can cause error because the DC current that powers the amplifier and sensor circuitry must flow through it. Ground potentials, if they cannot be swamped out with signal swing, would require that twisted pair lines be used. This is not so with current mode.

An important consideration is that cable capacitance does not affect the loop stability of the current-mode amplifier. However, large-amplitude noise appearing across the output can give problems. *Figure 17* shows the noise rejections of the LM10. The negative supply rejection applies in current-mode operations with the output connected to  $V^+$ . The rejection in this mode is not overly impressive, but transmission can be reduced by bypassing the load resistor. This done, noise slew limiting is the restricting factor in that excessive slew can give rise to a DC error. The maximum noise amplitude that can be tolerated for a 100  $\mu V$  input-referred DC error is plotted in *Figure 18*. These limits are not to be pushed as error increases rapidly above them.

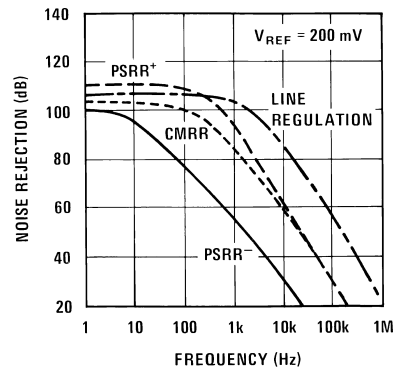

00720017

**FIGURE 17. Noise Rejection for the Various Elements of the Circuit**

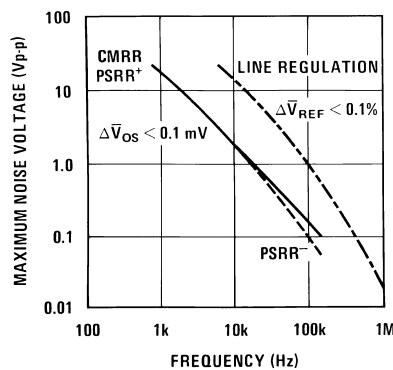

00720018

**FIGURE 18. Noise Frequency and Amplitude Required to give Indicated Error**

With voltage-mode, the circuit reacts to capacitive loading like any other op amp. If there are problems, the load should be isolated with a resistor, taking DC feedback from the load and AC feedback from the op amp output. With the LM10, it is also possible to bypass the output with a single, large capacitor (20  $\mu F$  electrolytic) if speed is no consideration.

With bridge sensors, these techniques not only reduce noise problems but only require two leads to both power the bridge and retrieve the signal.

The relevant circuit is shown in *Figure 19*. The op amp is wired for a high-impedance differential input so as not to load the bridge. The reference supplies the offset to put the amplifier in the center of its operating range when the bridge is balanced. It also powers the bridge. The low voltage available from the reference regulator is ideal for driving wire strain gauges that usually have low resistances.

Another form of remote signal processing is shown in *Figure 20*. A logarithmic conversion is made on the output current of a photodiode to compress a four-decade, light-intensity variation into a standard transmission range. The circuit is balanced at mid-range, where R3 should be chosen so that the current through it equals the photodiode current. The log-conversion slope is temperature compensated with R6. Setting the reference output to 1.22V gives a current through R2 that is proportional to absolute temperature, because of D1, so that this level-shift voltage matches the temperature

## Linear Operation (Continued)

coefficient of R6. C1 has been added so that large area photodiodes with high capacitance do not cause frequency instabilities.

Figure 21 shows a setup that optically measures the temperature of an incandescent body. It makes use of the shift in the emission spectrum of a black body toward shorter wavelengths as temperature is increased. Optical filters are used to split the emission spectrum, with one photodiode being illuminated by short wavelengths (visible light) and the other by long (infrared). The photocurrents are converted to loga-

rithms by Q1 and Q2. These are subtracted to generate an output that varies as the log of the ratio of the illumination intensities. Thus, the circuit is sensitive to changes in spectral distribution, but not intensity. Otherwise, the circuit is quite similar to that in Figure 20.

The laws of physics dictate that the output is not a simple function of temperature, so point-by-point calibration is necessary. Sensitivity for a particular temperature range is optimized with the crossover point of the optical filter, longer wavelengths giving lower temperatures.

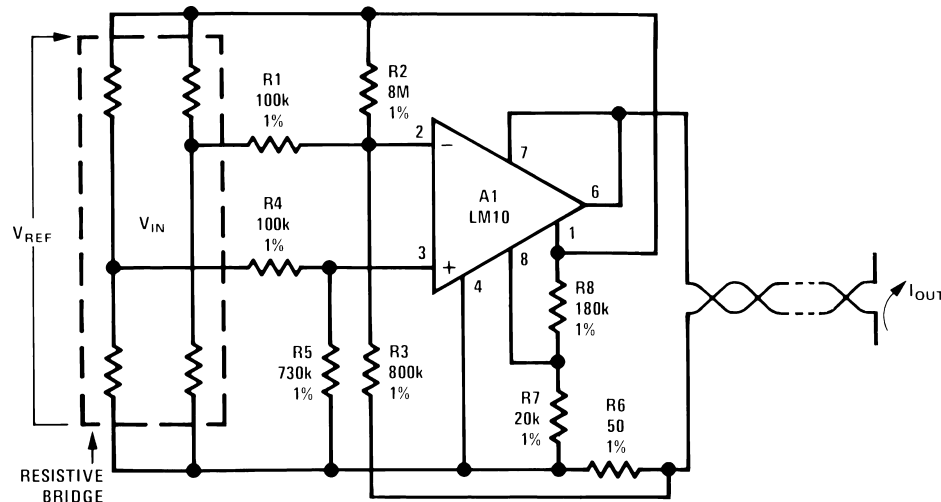

00720019

FIGURE 19. Two-Wire Transmitter for Resistive Bridge

Linear Operation (Continued)

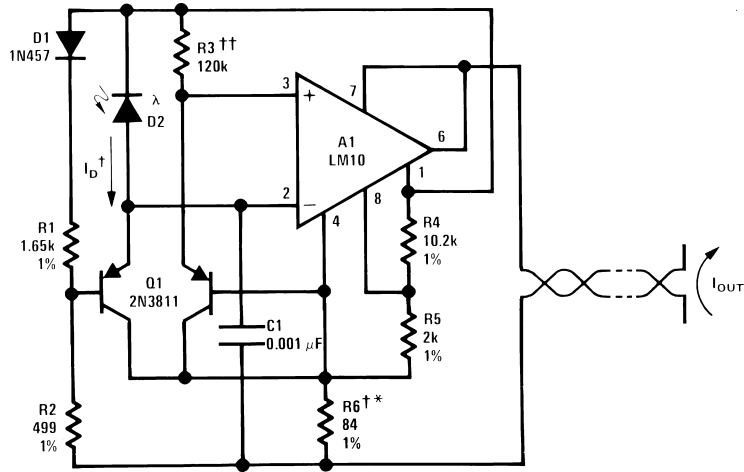

00720020

$$1 \text{ mA} \leq I_{OUT} \leq 5 \text{ mA}$$

$$0.01 \leq \frac{I_{D2}}{I_{D1}} \leq 100$$

‡50 μA ≤ ID ≤ 500 μF

††Center scale trim

†Scale factor trim

\*Copper wire wound

FIGURE 20. Log Converter/Transmitter for a Photodiode

$$1 \text{ mA} \leq I_{OUT} \leq 5 \text{ mA}$$

$$0.01 \leq \frac{I_{D2}}{I_{D1}} \leq 100$$

00720040

$$V_{OUT} = \frac{R2}{R1} V_{REF}$$

††Level-shift trim

\*Scale factor trim

†Copper wire wound

FIGURE 21. Optoelectric Pyrometer with Transmitter

## Linear Operation (Continued)

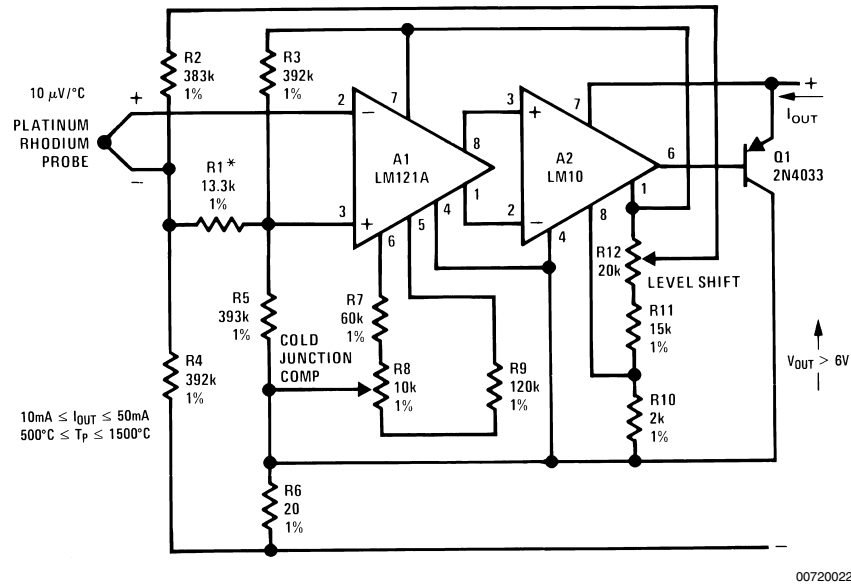

FIGURE 22. Precision Thermocouple Amplifier/Transmitter

Figure 22 shows how a low-drift preamplifier can be added to improve the measurement resolution of a thermocouple. The preamp is powered from the reference regulator, and bridge feedback is used to bias the preamp input within its common-mode range. Cold-junction compensation is provided with the offset voltage set into A1, it being directly proportional to absolute temperature.

The maximum drift specification for the preamp is  $0.2 \mu\text{V}/^\circ\text{C}$ . For this particular circuit, an equal drift component would result for  $0.004\%/^\circ\text{C}$  on the reference,  $0.001\%/^\circ\text{C}$  mismatch on the bridged-feedback resistors (R2–R4) or  $3 \mu\text{V}/^\circ\text{C}$  on the op amp offset voltage. The op amp drift might be desensitized by raising the preamp gain (lowering R7–R9), but this would require raising the output voltage of the reference regulator and the minimum terminal voltage.

In this application, the preamp is run at a lower voltage than standard parts are tested with, and the maximum supply current specified is high. However, there should be no problem with the voltage; and a lower, maximum supply current can be expected at the lower voltage. Even so, some testing may be in order.

## Regulators

The op amp and voltage reference are combined in Figure 23 to make a positive voltage regulator. The output can be set between  $0.2\text{V}$  and the breakdown voltage of the IC by selecting an appropriate value for R2. The circuit regulates for input voltages within a saturation drop of the output (typically  $0.4\text{V}$  @  $20\text{mA}$  and  $0.15\text{V}$  @  $5\text{mA}$ ). The regulator is protected from shorts or overloads by current limiting and thermal shutdown.

Typical regulation is about  $0.05\%$  load and  $0.003\%/V$  line. A substantial improvement in regulation can be effected by connecting the op amp as a follower and setting the reference to the desired output voltage. This has the disadvantage that the minimum input-output differential is increased

to a little more than a diode drop. If the op amp were connected for a gain of 2, the output could again saturate. But this requires an additional pair of precision resistors.

The regulator in Figure 23 could be made adjustable to zero by connecting the op amp to a potentiometer on the reference output. This has the disadvantage that the regulation at the lower voltage settings is not as good as it might otherwise be.

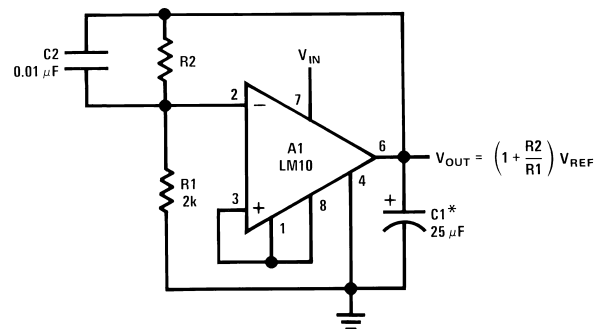

\*electrolytic

00720023

FIGURE 23. Adjustable Positive Regulator

It is also possible to make a negative regulator with this device, as can be seen from Figure 24. A discrete transistor is used to level shift the reference current. This increases the minimum operating voltage to about  $1.8\text{V}$ .

Output voltage cannot be reduced below  $0.85\text{V}$  because of the common-mode limit of the op amp. The minimum input-output differential is equal to the voltage across R1 plus the saturation voltage of Q1, about  $400\text{mV}$ .

It is necessary that Q1 has a high current gain, or line regulation and thermal drift will be degraded. For example, with a nominal current gain of 100, a  $1\%$  drift will be intro-

## Regulators (Continued)

duced between  $-55^{\circ}\text{C}$  and  $125^{\circ}\text{C}$ . With the device specified, drift contribution should be less than 0.3% over the same range; but operation is limited to 30V on the input.

Floating-mode operation can also be useful in regulator applications. In *Figure 25*, the op amp controls the turn-on voltage of the pass transistor in such a way that it does not

see either the output voltage or the supply voltage. Therefore, maximum voltages are limited only by the external transistors.

A three-stage emitter follower is used for the pass transistor primarily to insure adequate bias voltage for the IC under worst-case, high-temperature conditions. With lower output currents Q2 and R4 could be replaced with a diode.

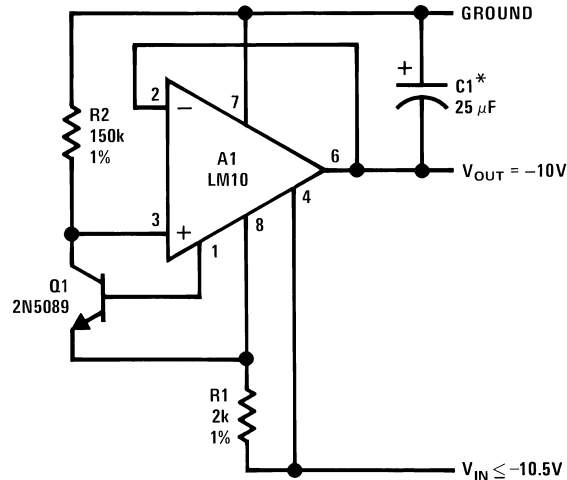

\*electrolytic

00720024

**FIGURE 24. Negative Regulator**

Load regulation is better than 0.01%. Worst-case line regulation is better than  $\pm 0.1\%$  for a  $\pm 10\text{V}$  change in input voltage. If the op amp output were buffered with a discrete PNP, load and line regulation could be made essentially perfect, except for thermal drift.

Current limiting, although not shown, could easily be provided by the addition of a sense resistor and an NPN transistor. A foldback characteristic could be obtained with two more resistors.

A fully adjustable voltage and current regulator is shown in *Figure 26*. A second IC (A2) is added to provide regulation in the current-limit mode. Both the regulated voltage and the current can be adjusted close to zero.

The circuit has a tendency to overshoot when a short circuit is removed. This is suppressed with Q2, R5 and C3, which limit the rate at which the output can rise. Low-level oscillations at the dropout threshold are eliminated with C2 and R4.

The current-limit amplifier takes about 100  $\mu\text{s}$  to respond to a shorted output. Therefore, Q6 has been added to limit the peak current during this interval.

## Regulators (Continued)

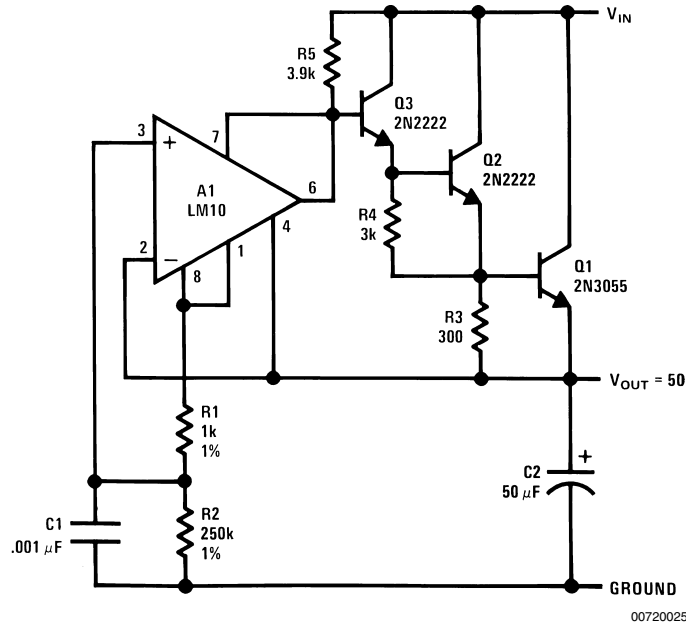
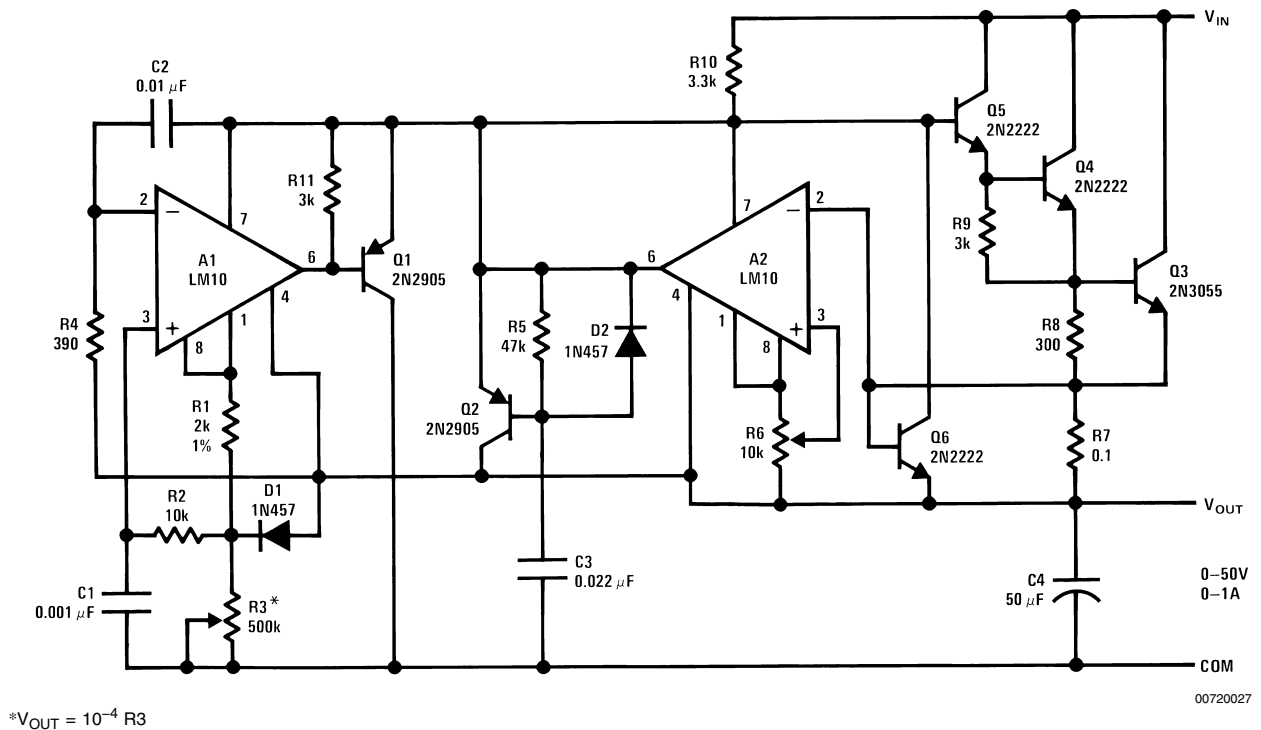

FIGURE 25. Bootstrapped Regulator



$$*V_{OUT} = 10^{-4} R3$$

FIGURE 26. Detailed Schematic of an Adjustable Voltage and Current Regulator

With high-voltage regulators, powering the IC through the drive resistor for the pass transistors can become quite inefficient. This is avoided with the circuit in *Figure 27*. The supply current for the IC is derived from Q1. This allows R4 to be increased by an order of magnitude without affecting the dropout voltage.

Selection of the output transistors will depend on voltage requirements. For output voltages above 200V, it may be more economical to cascade lower-voltage transistors.

*Figure 28* shows a more detailed circuit for a high-voltage regulator. Foldback current limiting has been added to protect the pass transistors from blowout caused by excessive

## Regulators (Continued)

heating or secondary breakdown. This limiting must be fairly precise to obtain reasonable start-up characteristics while conforming to worst case specifications for the transistors. This accounts for the complexity of the circuit.

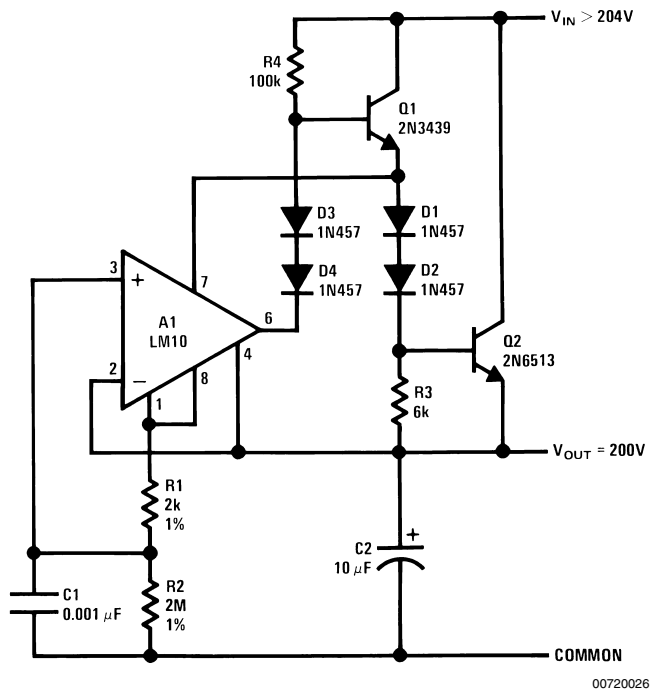

00720026

$$V_{OUT} = \frac{R2}{R1} V_{REF}$$

FIGURE 27. High-Voltage Regulator

## Regulators (Continued)

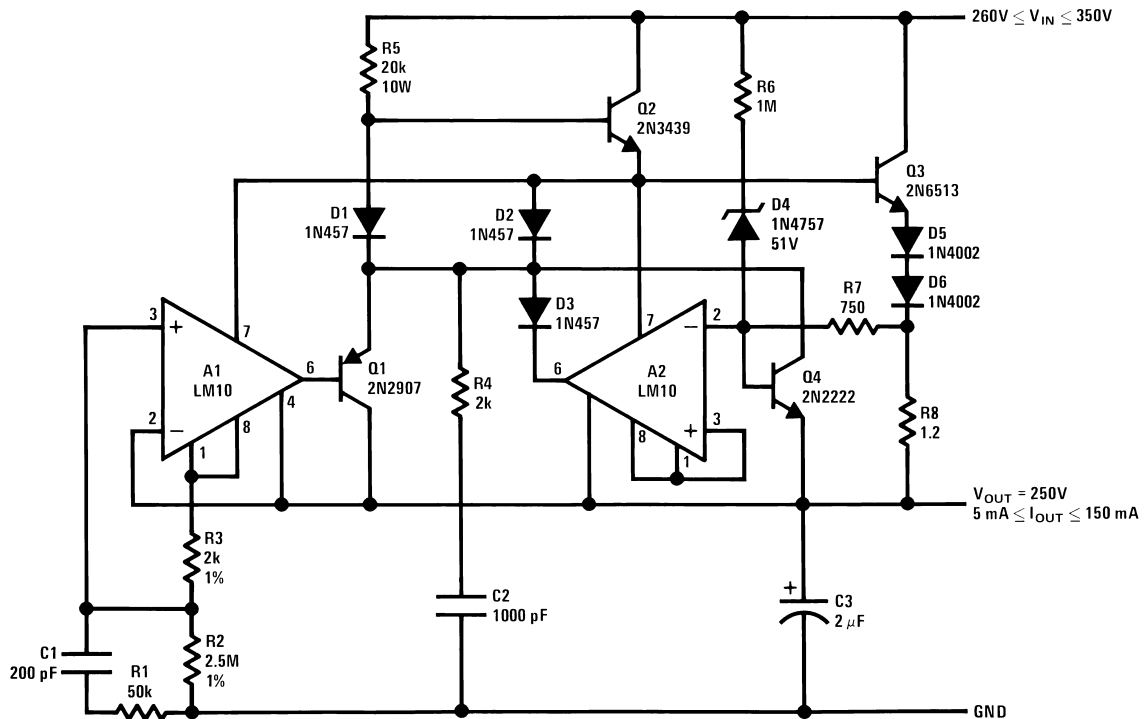

00720029

FIGURE 28. High Voltage Regulator with Foldback Current Limit

The output current is sensed across R8. This is delivered to the current limit amplifier through R7, across which the foldback potential is developed by R6 with a threshold determined by D4. The values given limit the peak power below 20W and shut off the pass transistors when the voltage across them exceeds 310V. With unregulated input voltages above this value, start-up is initiated solely by the current through R5. Q4 is added to provide some control on current before A2 has time to react.

The design could be considered overly conservative, but this may not be inappropriate considering the state of the art for high-voltage power transistors. Their maximum operating current is in the tens of milliamperes at maximum voltage. Cutting off the power transistor before the maximum input-output voltage differential is reached can cause start-up problems, depending on the nature of the load (those that tend toward a constant-current characteristic being worst).

If a tighter design is required for start-up, the values of R6 and D4 can be altered. In addition, R5 can be lowered, although it may be necessary to add a PNP buffer to A2 in place of D3.

The leakage current of Q3 can be more than several milliamperes. That is why a hard turn-off is provided with D2.

The circuit is stable with an output capacitor greater than about 2  $\mu$ F. Spurious oscillations in current limit are suppressed by C2 and R4, while a strange, latch-mode oscillation coming out of current limit is killed with C1 and R1.

Switching regulators operating directly from the power lines are seeing increased usage not only because of the reduced weight and size when compared to a 60 Hz transformer but

also because they operate over a wide voltage range giving a regulated output with reasonable efficiency. Electrical isolation of the load is generally required in these applications for reasons of safety. Therefore, if precise regulation is needed on the secondary, there must be some way of transmitting the error signal back to the primary.

Figure 29 shows a design that provides this function. The IC serves as a reference and error amplifier, transmitting the error signal through an optical coupler. The loop gain may be controlled by the addition of R1, and C1 and R5 may be added to develop the phase lead that is helpful in frequency stabilizing the feedback.



## Regulators (Continued)

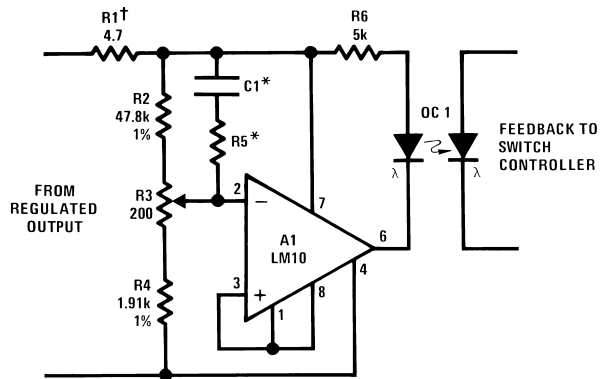

00720028

†controls "loop gain"

\*optional frequency shaping

**FIGURE 29. Isolated Sensor for an Off-Line Switching Regulator**

## Voltage Level Indicators

In battery-powered circuitry, there is some advantage to having an indicator to show when the battery voltage is high enough for proper circuit operation. This is especially true for instruments that can produce erroneous data.

The battery status indicator drawn in *Figure 30* is designed for a 9V source. It begins dimming noticeably below 7V and extinguishes at 6V. If the warning of incipient battery failure is not desired, R3 can be removed and the value of R1 halved.

A second circuit that also regulates the current through the light-emitting diode is shown in *Figure 31*. This is important so that adequate current is available at minimum voltage, but excessive current is not drawn at maximum voltage. Current regulation is accomplished by using the voltage on the balance pin (5) as a reference for the op amp. This is controlled at approximately 23 mV, independent of temperature, by an internal regulator. When the voltage on the reference-feedback terminal (8) drops below 200 mV, the reference output (1) rises to supply the feedback voltage to the op amp through D2, so the LED current drops to zero.

The minimum threshold voltage for these circuits is basically limited by the bias voltage for the LEDs. Typically, this is 1.7V for red, 2V for green and 2.5V for yellow. These two circuits can be made to operate satisfactorily for threshold voltages as low as 2V if a red diode is used. However, the circuit in *Figure 31* is preferred in that difficulties caused by voltage change across the diode biasing resistor are eliminated.

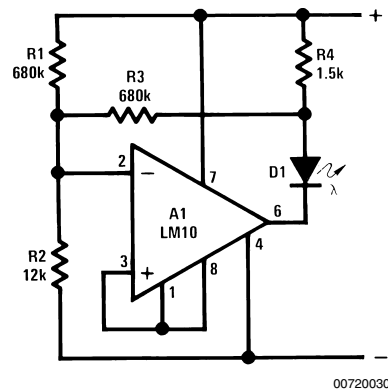

00720030

 $V_{TH} = 6V$ 

LED dims below 7V

**FIGURE 30. Battery Status Indicator**

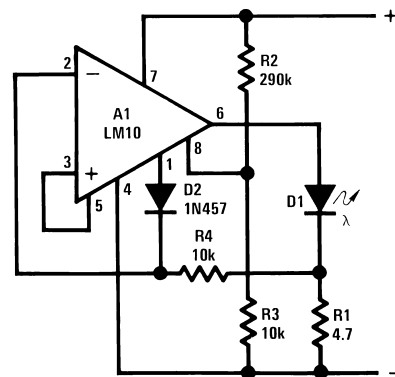

00720031

 $V_{TH} = 6V$  $I_{D1} = 5 mA$ 

**FIGURE 31. Battery Level Indicator with Regulated LED Current**

When operating with a single cell, it is necessary to incorporate switching circuitry to develop sufficient voltage to drive the LED. A circuit that accomplishes this is drawn in *Figure 32*. Basically, it is a voltage-controlled asymmetrical multivibrator with a minimum operating threshold given by

$$V_{TH} = \frac{R4(R1 + R2)}{R1(R3 + R4)} V_{REF} \quad (1)$$

Above this threshold, the flash frequency increases with voltage. This is a far more noticeable indication of a deteriorating battery than merely dimming the LED. In addition, the indicator can be made visible with considerably less power drain. With the values shown, the flash rate is  $1.4 \text{ sec}^{-1}$  at 1.2V with a  $300 \mu A$  drain and  $5.5 \text{ sec}^{-1}$  at 1.55V with  $800 \mu A$  drain. Equivalent visibility for continuous operation would require more than 5 mA drain.

The maximum threshold voltage of this circuit is limited because the LED can be turned on directly through R5. Once this happens, the full supply voltage is not delivered to R2, which is how the threshold is determined. This problem can be overcome with the circuit illustrated in *Figure 33*. This

## Voltage Level Indicators (Continued)

design repositions the indicator diode, requiring an input voltage somewhat greater than the diode bias voltage needed.

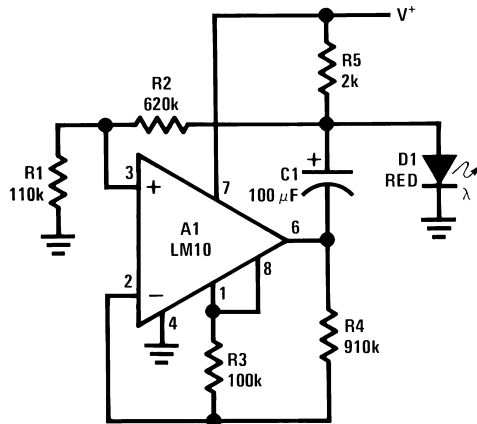

flashes about 1.2V, rate increases with voltage

00720032

FIGURE 32. Undervoltage Indicator for Single Call

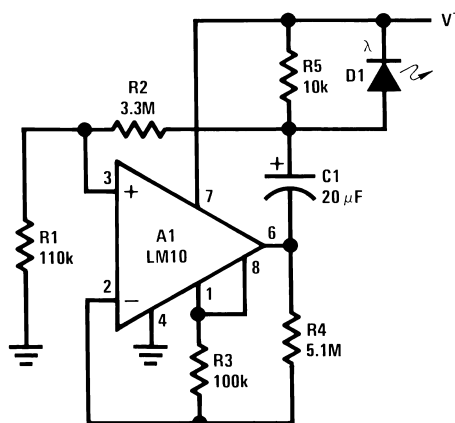

$V_{TH}' = 15V$

$V_{TH} = 6V$

flash rate increases above 6V and below 15V

00720033

FIGURE 33. Double-Ended Voltage Monitor

This circuit has the added feature that it can sense an overvoltage condition. The lower activation threshold is given by equation (1), but above a threshold,

$$V_{TH}' = \frac{R4 (R1 + R2) V_{REF}}{R1 (R3 + R4) - R3 (R1 + R2)} \quad (2)$$

oscillation again ceases. (Below  $V_{TH}$  the op amp output is saturated negative while above  $V_{TH}'$  it is saturated positive.) The flash rate approaches zero near either limit.

The minimum/maximum limits possible with this circuit along with the possibility of estimating the proximity to the limit and the low power drain ( $\sim 500 \mu A$ ) make it attractive for a variety

of simple, low-cost test equipment. This could include everything from the measurement of power-line voltage to in-circuit testers for digital equipment.

## Meter Circuits

One obvious application for this IC is a meter amplifier. Accuracy can be maintained over a  $15^\circ C$  to  $55^\circ C$  range for a full-scale sensitivity of 10 mV and 100 nA using the design in Figure 34. In fact, initial tests indicate negligible zero drift with 1 mV and 10 nA sensitivities, although balancing is troublesome with low-cost potentiometers. Offset voltage error is nulled with R5, and the bias current can be balanced

## Meter Circuits (Continued)

out with R4. The zeroing circuit operates from the reference output and are essentially unaffected by changes in battery voltage, so frequent adjustments should not be necessary.

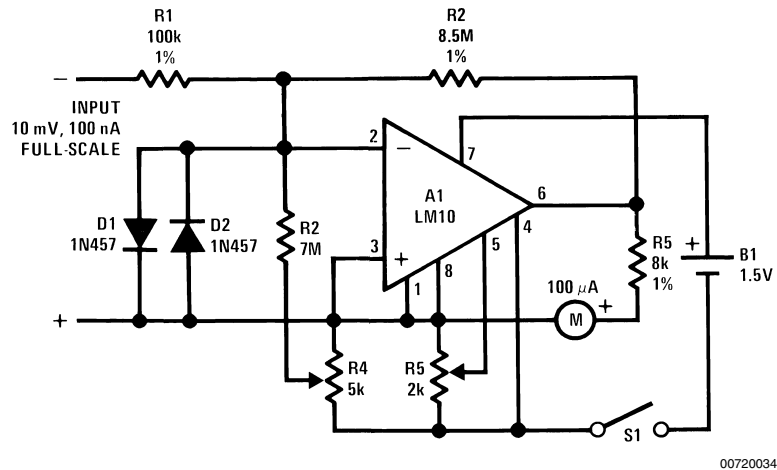

FIGURE 34. Meter Amplifier

Under overload conditions, the current delivered to the meter is kept well in hand by the limited output swing of the op amp. The same is true for polarity reversals. Input clamp diodes protect the circuit from gross overloads.

Total current drain is under 0.5 mA, giving an approximate life of 3–6 months with an “AA” cell and over a year with a “D” cell. With these lifetimes an ON/OFF switch may be unnecessary. A test switch that converts to a battery-test mode may be of greater value.

If the meter amplifier is used in building a multimeter, the internal reference can also be used in measuring resistance. This would make the usual frequent recalibration with falling cell voltage unnecessary.

A portable light-level meter with a five-decade dynamic range is shown in Figure 36. The circuit is calibrated at mid-range with the appropriate illumination by adjusting R2 such that the amplifier output equals the reference and the meter is at center scale. The emitter-base voltage of Q2 will vary with supply voltage; so R4 is included to minimize the effect on circuit balance. If photocurrents less than 50 nA are to be measured, it is necessary to compensate the bias current of the op amp.

The logging slope is not temperature compensated. With a five-decade response, the error at the scale extremes will be about 40% (a half stop in photography) for a  $\pm 18^\circ\text{C}$  temperature change.

If temperature compensation is desired, it is best to use a center-zero meter to introduce the offset, rather than the reference voltage. This done, temperature compensation can be obtained by making the resistor in series with the meter a copper wire-wound unit.

If this design is to be used for photography, it is important to remember that silicon photodiodes are sensitive to near

infrared, whereas ordinary film is not. Therefore, an infrared-stop filter is called for. A blue-enhanced photodiode or an appropriate correction filter would also give best results.

An electronic thermometer design, useful in the range of  $-55^\circ\text{C}$  to  $150^\circ\text{C}$ , is shown in Figure 35. The sensor, S1, develops a current that is proportional to absolute temperature. This is given the required offset and range expansion by the reference and op amp, resulting in a direct readout in either  $^\circ\text{C}$  or  $^\circ\text{F}$ .

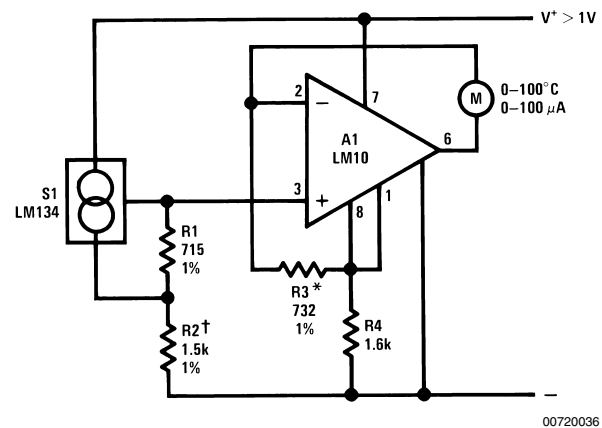

\*trim for span

†trim for zero

FIGURE 35. Electronic Thermometer

## Meter Circuits (Continued)

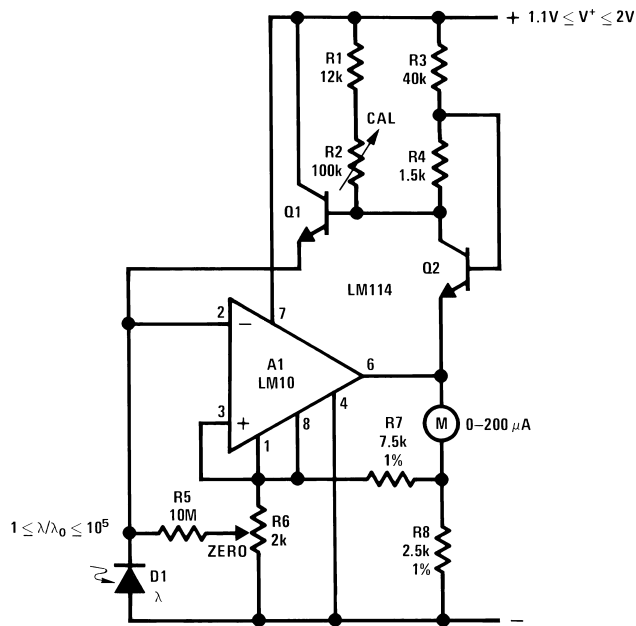

00720035

FIGURE 36. Logarithmic Light-Level Meter

Although it can operate down to 1V with better than 0.5°C accuracy, the LM134 is not tested below 1.5V. Maverick units were observed to develop a 1°C error going from 1.5V to 1.2V. This should be kept in mind for high-accuracy applications.

The thermocouple transmitter in *Figure 15* can easily be modified to work with a meter if a broader temperature range is of interest. It would likewise be no great problem adapting resistance or thermistor sensors to this function.

## Audio Circuits

As mentioned earlier, the frequency response of the LM10 is not as good as might be desired. The frequency-response curve in *Figure 37* shows that only moderate gains can be realized in the audio range. However, considering the reference, there are two independent amplifiers available, so that reasonable overall performance can be obtained.

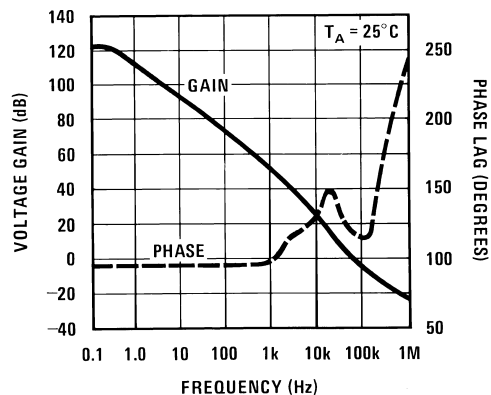

00720037

FIGURE 37. Open Loop Frequency Response

## Audio Circuits (Continued)

This is illustrated with the microphone amplifier shown in *Figure 38*. The reference, with a 500 kHz unity-gain bandwidth, is used as a preamplifier with a gain of 100. Its output is fed through a gain-control potentiometer to the op amp which is connected for a gain of 10. The combination gives a 60 dB gain with a 10 kHz bandwidth, unloaded, and 5 kHz loaded at 500Ω. Input impedance is 10 kΩ.

Potentially, using the reference as a preamplifier in this fashion can cause excess noise. However, because the reference voltage is low, the noise contribution, which adds root-mean-square, is likewise low. The input noise voltage in this connection is 40–50 nV/√Hz, about equal to that of the op amp.

One point to observe with this connection is that the signal swing at the reference output is strictly limited. It cannot swing much below 150 mV nor closer than 800 mV to the

supply. Further, the bias current at the reference feedback terminal lowers the output quiescent level and generates an uncertainty in this level. These facts limit the maximum feedback resistance (R5) and require that R6 be used to optimize the quiescent operating voltage on the output. Even so, the fact that limited swing on the preamplifier can reduce maximum output power with low settings on the gain control must be considered.

In this design, no DC current flows in the gain control. This is perhaps an arbitrary rule, designed to insure long life with noise-free operation. If violations of this rule are acceptable, R5 can be used as the gain control with only the bias current for the reference amplifier (<75 nA) flowing through the wiper. This simplifies the circuit and gives more leeway on getting sufficient output swing from the preamplifier.

The circuit in *Figure 38* can also be modified to provide two-wire transmission for a microphone output.

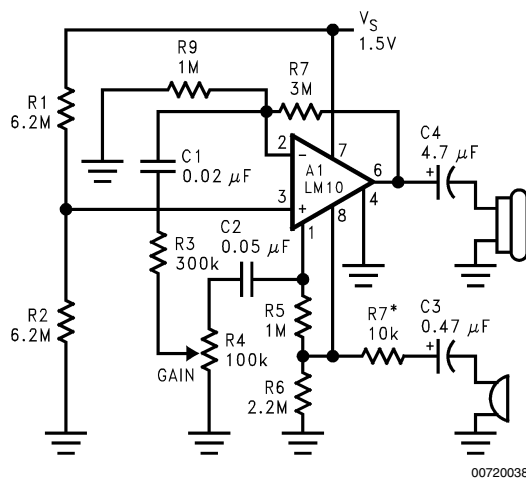

$Z_{OUT} \sim 680\Omega$ , @5 kHz,  $A_V \leq 1k$ ,  $f_1 \sim 100$  Hz,  
 $f_2 \sim 5$  kHz,  $R_L \sim 500$ , \*max gain trim

00720038

FIGURE 38. Microphone Amplifier

## Conclusions

The applications described here show that some truly unique functions can be performed by the LM10 because of the low-voltage capability and floating mode operation. Among these are accurate, two-terminal comparators that interface directly with most logic forms. They can also drive SCRs in control circuits using low-level sensors like photodiodes or thermocouples, although this was not explored here.

Two-wire transmitters for analog signals were shown to work with a variety of transducers, even to the extent of remotely performing computational functions. These might be used for anything from a microphone preamplifier to a strain gauge measuring stress at some remote location in an aircraft. The power requirements of this IC are modest enough to insure a wide dynamic range and permit operation with lower-voltage supplies.

The IC also proves to be quite useful in regulator circuits, as might be expected from a combined op amp and voltage reference. It makes an efficient series regulator at low voltages. And as a low-level, on-card regulator, it offers greater precision than existing devices. It is also easily applied as a shunt regulator or current regulator.

In the floating mode, it operates with the precision required of laboratory supplies, as either a voltage or current regulator. Maximum output voltage is limited only by discrete pass transistors, because the control circuit sees, at most, a couple volts. Therefore, output voltages of several hundred volts are entirely practical.

A few examples were given of amplifiers and signal conditioners for portable instruments. Emphasis was placed on single-supply operation as this gives the longest life at lowest cost from the smallest power source. The IC is well suited to single-supply operation, where it can be used in any number of standard applications. This can be put to use in digital systems where some linear functions must be performed. The availability of a reference allows precise level shifting or comparisons even when the supply is poorly regulated. The reference can also be used to create an elevated pseudo-ground so that split-supply techniques can be used.

Even when split supplies are available, the increased output capability (40V @ 20 mA) coupled with lower power consumption could well recommend the LM10. This is combined with the more satisfactory fault protection provided by thermal limiting.

## Acknowledgement

The authors would like to thank Dick Wong for his assistance in building and checking out the applications described here.

\*See Addendum in Application Note TP-14.

## References

1. R. J. Widlar, "Low Voltage Techniques," *IEEE J. Solid-State Circuits*, Dec. 1978.

## LIFE SUPPORT POLICY

NATIONAL'S PRODUCTS ARE NOT AUTHORIZED FOR USE AS CRITICAL COMPONENTS IN LIFE SUPPORT DEVICES OR SYSTEMS WITHOUT THE EXPRESS WRITTEN APPROVAL OF THE PRESIDENT AND GENERAL COUNSEL OF NATIONAL SEMICONDUCTOR CORPORATION. As used herein:

1. Life support devices or systems are devices or systems which, (a) are intended for surgical implant into the body, or (b) support or sustain life, and whose failure to perform when properly used in accordance with instructions for use provided in the labeling, can be reasonably expected to result in a significant injury to the user.
2. A critical component is any component of a life support device or system whose failure to perform can be reasonably expected to cause the failure of the life support device or system, or to affect its safety or effectiveness.



**National Semiconductor Corporation**  
Americas  
Email: support@nsc.com

www.national.com

**National Semiconductor Europe**

Fax: +49 (0) 180-530 85 86  
Email: europe.support@nsc.com  
Deutsch Tel: +49 (0) 69 9508 6208  
English Tel: +44 (0) 870 24 0 2171  
Français Tel: +33 (0) 1 41 91 8790

**National Semiconductor Asia Pacific Customer Response Group**

Tel: 65-2544466  
Fax: 65-2504466  
Email: ap.support@nsc.com

**National Semiconductor Japan Ltd.**

Tel: 81-3-5639-7560  
Fax: 81-3-5639-7507