



CAT24C04

4-Kb I²C CMOS Serial EEPROM

FEATURES

- Supports Standard and Fast I²C Protocol
- 1.8 V to 5.5 V Supply Voltage Range
- 16-Byte Page Write Buffer
- Hardware Write Protection for entire memory
- Schmitt Triggers and Noise Suppression Filters on I²C Bus Inputs (SCL and SDA).
- Low power CMOS technology
- 1,000,000 program/erase cycles
- 100 year data retention
- RoHS compliant **“Green”** & **“Gold”** 8-pin PDIP, SOIC, TSSOP and TDFN packages
- Industrial temperature range

DEVICE DESCRIPTION

The CAT24C04 is a 4-Kb Serial CMOS EEPROM, internally organized as 32 pages of 16 bytes each, for a total of 512 bytes of 8 bits each.

It features a 16-byte page write buffer and supports both the Standard (100 kHz) as well as Fast (400 kHz) I²C protocol.

Write operations can be inhibited by taking the WP pin High (this protects the entire memory).

The CAT24C04 is available in RoHS compliant “Green” and “Gold” 8-lead PDIP, SOIC, TSSOP and TDFN packages.

PIN CONFIGURATION

	PDIP (L)	SOIC (W)	TSSOP (Y)	TDFN (VP2)
NC	1	8	V _{CC}	
A ₁	2	7	WP	
A ₂	3	6	SCL	
V _{SS}	4	5	SDA	

For the location of Pin 1, please consult the corresponding package drawing.

FUNCTIONAL SYMBOL

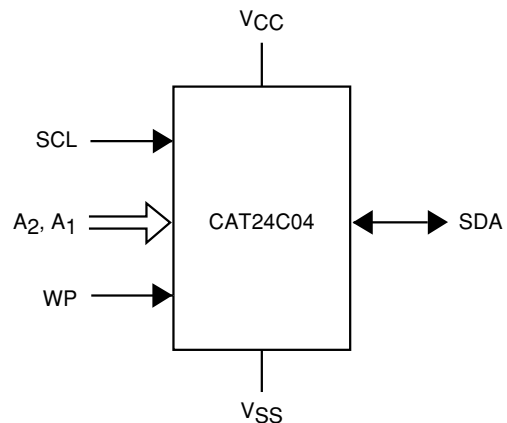

PIN FUNCTIONS

A ₁ , A ₂	Device Address
SDA	Serial Data
SCL	Serial Clock
WP	Write Protect
V _{CC}	Power Supply
V _{SS}	Ground
NC	No Connect

* Catalyst carries the I²C protocol under a license from the Philips Corporation.

ABSOLUTE MAXIMUM RATINGS*

Storage Temperature	-65°C to +150°C
Voltage on Any Pin with Respect to Ground ⁽¹⁾	-0.5 V to +6.5 V

* Stresses above those listed under “Absolute Maximum Ratings” may cause permanent damage to the device. These are stress ratings only, and functional operation of the device at these or any other conditions outside of those listed in the operational sections of this specification is not implied. Exposure to any absolute maximum rating for extended periods may affect device performance and reliability.

RELIABILITY CHARACTERISTICS⁽²⁾

Symbol	Parameter	Min	Units
N _{END} (*)	Endurance	1,000,000	Program/ Erase Cycles
T _{DR}	Data Retention	100	Years

(*) Page Mode, V_{CC} = 5 V, 25°C

D.C. OPERATING CHARACTERISTICS

V_{CC} = 1.8 V to 5.5 V, T_A = -40°C to 85°C, unless otherwise specified.

Symbol	Parameter	Test Conditions	Min	Max	Units
I _{CC}	Supply Current	Read or Write at 400 kHz		1	mA
I _{SB}	Standby Current	All I/O Pins at GND or V _{CC}		1	μA
I _L	I/O Pin Leakage	Pin at GND or V _{CC}		1	μA
V _{IL}	Input Low Voltage		-0.5	V _{CC} × 0.3	V
V _{IH}	Input High Voltage		V _{CC} × 0.7	V _{CC} + 0.5	V
V _{OL1}	Output Low Voltage	V _{CC} > 2.5 V, I _{OL} = 3.0 mA		0.4	V
V _{OL2}	Output Low Voltage	V _{CC} > 1.8 V, I _{OL} = 1.0 mA		0.2	V

PIN IMPEDANCE CHARACTERISTICS

T_A = 25°C, f = 400 kHz, V_{CC} = 5 V

Symbol	Parameter	Conditions	Min	Max	Units
C _{IN} ⁽²⁾	SDA I/O Pin Capacitance	V _{IN} = 0 V		8	pF
C _{IN} ⁽²⁾	Input Capacitance (other pins)	V _{IN} = 0 V		6	pF
Z _{WPL}	WP Input Low Impedance	V _{IN} < 0.5 V	5	70	kΩ
I _{LWPH}	WP Input High Leakage	V _{IN} > V _{CC} × 0.7		1	μA

Note:

- (1) The DC input voltage on any pin should not be lower than -0.5 V or higher than V_{CC} + 0.5 V. During transitions, the voltage on any pin may undershoot to no less than -1.5 V or overshoot to no more than V_{CC} + 1.5 V, for periods of less than 20 ns.
- (2) These parameters are tested initially and after a design or process change that affects the parameter according to appropriate AEC-Q100 and JEDEC test methods.

A.C. CHARACTERISTICS

$V_{CC} = 1.8\text{ V to }5.5\text{ V}$, $T_A = -40^\circ\text{C to }85^\circ\text{C}$, unless otherwise specified.

Symbol	Parameter	1.8 V - 5.5 V		2.5 V - 5.5 V		Units
		Min	Max	Min	Max	
F_{SCL}	Clock Frequency		100		400	kHz
$T_I^{(1)}$	Noise Suppression Time Constant at SCL, SDA Inputs		0.1		0.1	μs
$t_{AA}^{(2)}$	SCL Low to SDA Data Out		3.5		0.9	μs
$t_{BUF}^{(1)}$	Time the Bus Must be Free Before a New Transmission Can Start	4.7		1.3		μs
$t_{HD:STA}$	Start Condition Hold Time	4		0.6		μs
t_{LOW}	Clock Low Period	4.7		1.3		μs
t_{HIGH}	Clock High Period	4		0.6		μs
$t_{SU:STA}$	Start Condition Setup Time	4.7		0.6		μs
$t_{HD:DAT}$	Data In Hold Time	0		0		μs
$t_{SU:DAT}$	Data In Setup Time	0.25		0.1		μs
$t_R^{(1)}$	SDA and SCL Rise Time		1		0.3	μs
$t_F^{(1)}$	SDA and SCL Fall Time		0.3		0.3	μs
$t_{SU:STO}$	Stop Condition Setup Time	4		0.6		μs
t_{DH}	Data Out Hold Time	0.1		0.1		μs
t_{WR}	Write Cycle Time		5		5	ms
$t_{PU}^{(1), (3)}$	Power-up to Ready Mode		1		1	ms

Note:

- (1) This parameter is tested initially and after a design or process change that affects the parameter.
- (2) For timing measurements the SDA line capacitance is $\sim 100\text{ pF}$; the SCL input is driven with rise and fall times of $< 50\text{ ns}$; the SDA I/O is pulled-up by a 3 mA current source; input driving signals swing from 20% to 80% of V_{CC} . Output level reference levels are 30% and respectively 70% of V_{CC} .
- (3) t_{PU} is the delay required from the time V_{CC} is stable until the device is ready to accept commands.

Power-On Reset (POR)

The CAT24C04 incorporates Power-On Reset (POR) circuitry which protects the internal logic against powering up in the wrong state.

The CAT24C04 will power up into Standby mode after V_{CC} exceeds the POR trigger level and will power down into Reset mode when V_{CC} drops below the POR trigger level. This bi-directional POR feature protects the device against 'brown-out' failure following a temporary loss of power.

The POR circuitry triggers at the minimum V_{CC} level required for proper initialization of the internal state machines. The POR trigger level automatically tracks the internal CMOS device thresholds, and is naturally well below the minimum recommended V_{CC} supply voltage.

PIN DESCRIPTION

SCL: The Serial Clock input pin accepts the Serial Clock generated by the Master.

SDA: The Serial Data I/O pin receives input data and transmits data stored in EEPROM. In transmit mode, this pin is open drain. Data is acquired on the positive edge, and is delivered on the negative edge of SCL.

A₁ and A₂: The Address pins accept the device address. These pins have on-chip pull-down resistors.

WP: The Write Protect input pin inhibits all write operations, when pulled HIGH. This pin has an on-chip pull-down resistor.

FUNCTIONAL DESCRIPTION

The CAT24C04 supports the Inter-Integrated Circuit (I²C) Bus data transmission protocol, which defines a device that sends data to the bus as a transmitter and a device receiving data as a receiver. Data flow is controlled by a Master device, which generates the serial clock and all START and STOP conditions. The CAT24C04 acts as a Slave device. Master and Slave alternate as either transmitter or receiver. Up to 4 devices may be connected to the bus as determined by the device address inputs A₁, and A₂.

I²C BUS PROTOCOL

The I²C bus consists of two 'wires', SCL and SDA. The two wires are connected to the V_{CC} supply via pull-up resistors. Master and Slave devices connect to the 2-wire bus via their respective SCL and SDA pins. The transmitting device pulls down the SDA line to 'transmit' a '0' and releases it to 'transmit' a '1'.

Data transfer may be initiated only when the bus is not busy (see A.C. Characteristics).

During data transfer, the SDA line must remain stable while the SCL line is HIGH. An SDA transition while SCL is HIGH will be interpreted as a START or STOP condition (Figure 1).

START

The START condition precedes all commands. It consists of a HIGH to LOW transition on SDA while SCL is HIGH. The START acts as a 'wake-up' call to all receivers. Absent a START, a Slave will not respond to commands.

STOP

The STOP condition completes all commands. It consists of a LOW to HIGH transition on SDA while SCL is HIGH. The STOP starts the internal Write cycle (when following a Write command) or sends the Slave into standby mode (when following a Read command).

Device Addressing

The Master initiates data transfer by creating a START condition on the bus. The Master then broadcasts an 8-bit serial Slave address. The first 4 bits of the Slave address are set to 1010, for normal Read/Write operations (Figure 2). The next 2 bits, A₂ and A₁, select one of 4 possible Slave devices. The next significant bit (a8) is the memory array address bit. The last bit, R/W, specifies whether a Read (1) or Write (0) operation is to be performed.

Acknowledge

After processing the Slave address, the Slave responds with an acknowledge (ACK) by pulling down the SDA line during the 9th clock cycle (Figure 3). The Slave will also acknowledge the byte address and every data byte presented in Write mode. In Read mode the Slave shifts out a data byte, and then releases the SDA line during the 9th clock cycle. If the Master acknowledges the data, then the Slave continues transmitting. The Master terminates the session by not acknowledging the last data byte (NoACK) and by sending a STOP to the Slave. Bus timing is illustrated in Figure 4.

Figure 1. Start/Stop Timing

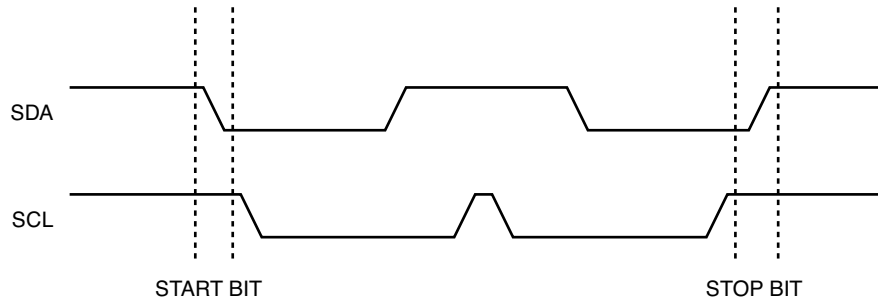

Figure 2. Slave Address Bits

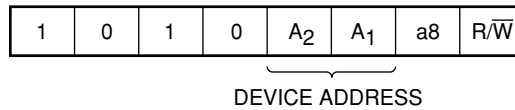

Figure 3. Acknowledge Timing

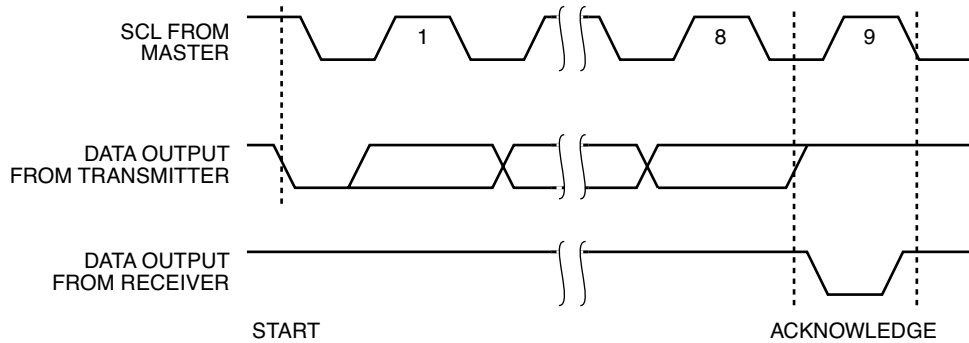
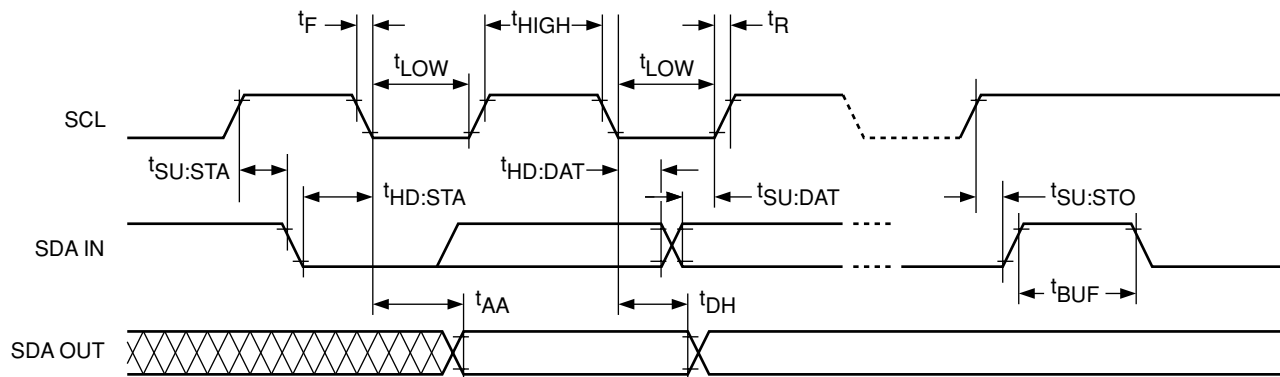

Figure 4. Bus Timing



WRITE OPERATIONS

Byte Write

In Byte Write mode the Master sends a START, followed by Slave address, byte address and data to be written (Figure 5). The Slave acknowledges all 3 bytes, and the Master then follows up with a STOP, which in turn starts the internal Write operation (Figure 6). During internal Write, the Slave will not acknowledge any Read or Write request from the Master.

Page Write

The CAT24C04 contains 512 bytes of data, arranged in 32 pages of 16 bytes each. A page is selected by the 4 most significant bits of the address byte following the Slave address, plus a8 of the Slave address, while the 4 least significant bits point to the byte within the page. Up to 16 bytes can be written in one Write cycle (Figure 7).

The internal byte address counter is automatically incremented after each data byte is loaded. If the Master transmits more than 16 data bytes, then earlier bytes will be overwritten by later bytes in a 'wrap-around' fashion (within the selected page). The internal Write cycle starts immediately following the STOP.

Acknowledge Polling

Acknowledge polling can be used to determine if the CAT24C04 is busy writing or is ready to accept commands. Polling is implemented by interrogating the device with a 'Selective Read' command (see READ OPERATIONS).

The CAT24C04 will not acknowledge the Slave address, as long as internal Write is in progress.

Hardware Write Protection

With the WP pin held HIGH, the entire memory is protected against Write operations. If the WP pin is left floating or is grounded, it has no impact on the operation of the CAT24C04.

Figure 5. Byte Write Timing

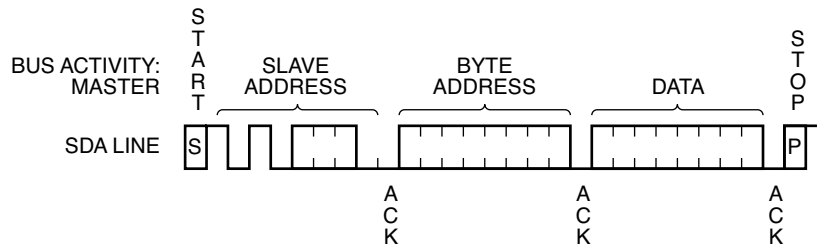

Figure 6. Write Cycle Timing

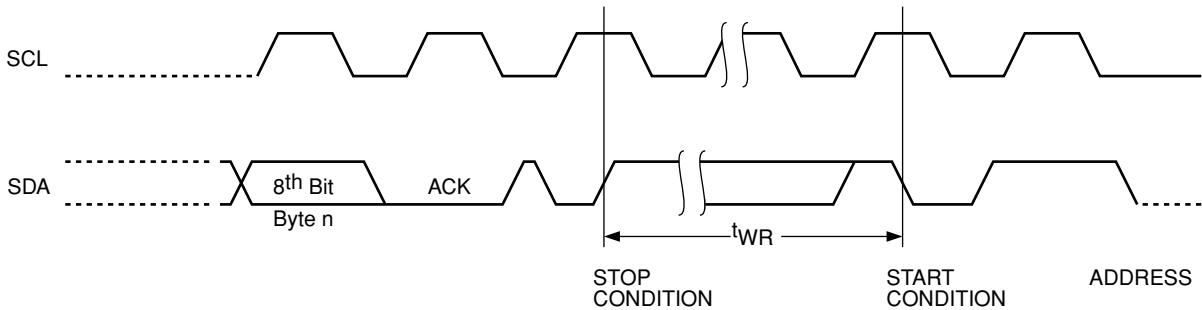
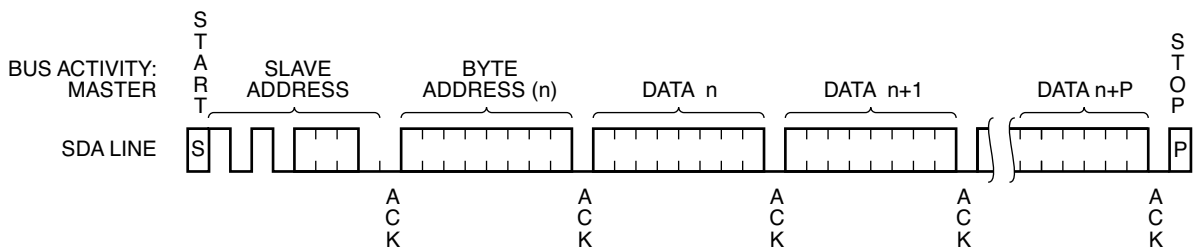

Figure 7. Page Write Timing



NOTE: IN THIS EXAMPLE $n = \text{XXXX } 0000(\text{B})$; $X = 1 \text{ or } 0$

READ OPERATIONS

Immediate Address Read

In standby mode, the CAT24C04 internal address counter points to the data byte immediately following the last byte accessed by a previous operation. If that 'previous' byte was the last byte in memory, then the address counter will point to the 1st memory byte, etc.

When, following a START, the CAT24C04 is presented with a Slave address containing a '1' in the R/W bit position (Figure 8), it will acknowledge (ACK) in the 9th clock cycle, and will then transmit data being pointed at by the internal address counter. The Master can stop further transmission by issuing a NoACK, followed by a STOP condition.

Selective Read

The Read operation can also be started at an address different from the one stored in the internal address counter. The address counter can be initialized by performing a 'dummy' Write operation (Figure 9). Here the START is followed by the Slave address (with the R/W bit set to '0') and the desired byte address. Instead of following up with data, the Master then issues a 2nd START, followed by the 'Immediate Address Read' sequence, as described earlier.

Sequential Read

If the Master acknowledges the 1st data byte transmitted by the CAT24C04, then the device will continue transmitting as long as each data byte is acknowledged by the Master (Figure 10). If the end of memory is reached during sequential Read, then the address counter will 'wrap-around' to the beginning of memory, etc. Sequential Read works with either 'Immediate Address Read' or 'Selective Read', the only difference being the starting byte address.

Figure 8. Immediate Address Read Timing

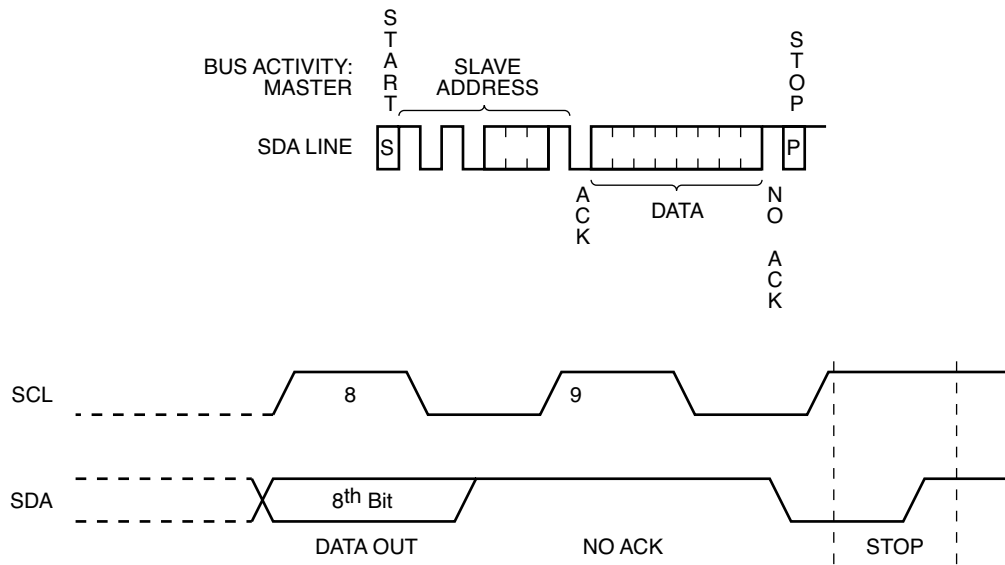

Figure 9. Selective Read Timing

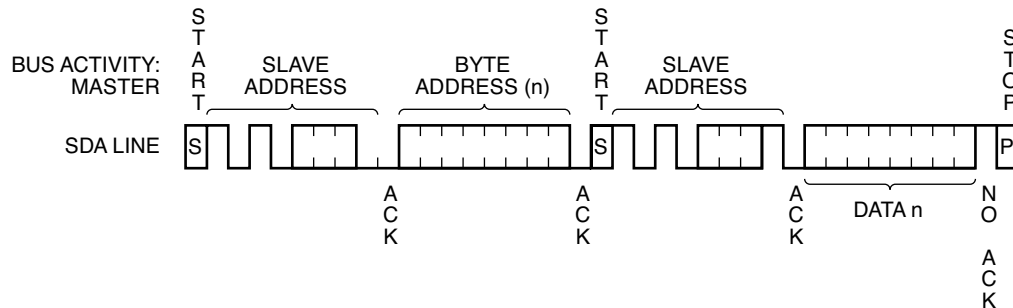
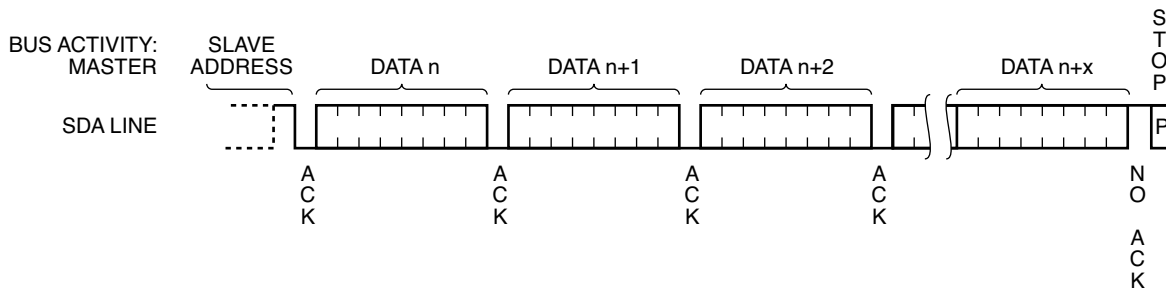
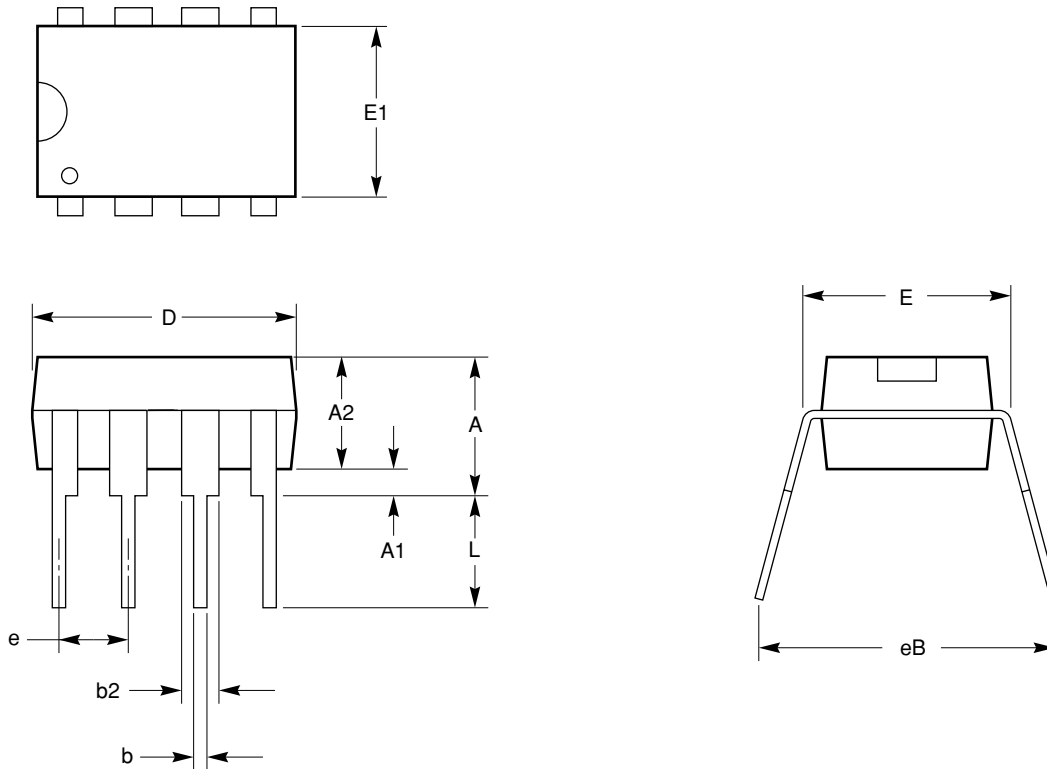

Figure 10. Sequential Read Timing



8-LEAD 300 MIL WIDE PLASTIC DIP (L)



SYMBOL	MIN	NOM	MAX
A	0.120		0.210
A1	0.015		
A2	0.115	0.130	0.195
b	0.014	0.018	0.022
b2	0.045	0.060	0.070
D	0.355	0.365	0.400
D2	0.300		0.325
E	0.300	0.310	0.325
E1	0.240	0.250	0.280
e		0.100 BSC	
eB			0.430
L	0.115	0.130	0.150

24C04_8-LEAD_DIP_(300P).eps

Notes:

1. Complies with JEDEC Standard MS001.
2. All dimensions are in inches.
3. Dimensioning and tolerancing per ANSI Y14.5M-1982

8-LEAD 150 MIL WIDE SOIC (W)

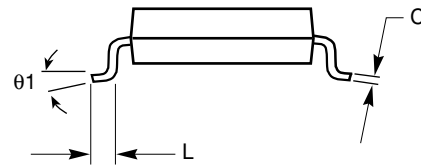
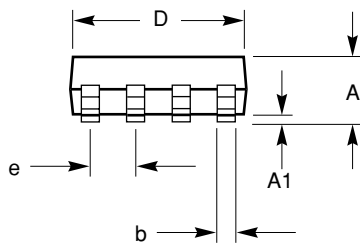
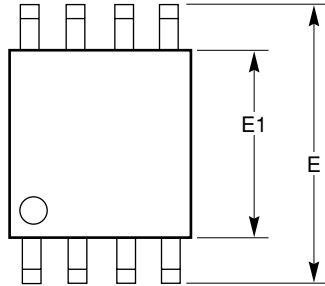

SYMBOL	MIN	NOM	MAX
A1	0.0040		0.0098
A2	0.0532		0.0688
b	0.013		0.020
C	0.0075		0.0098
D	0.1890		0.1968
E	0.2284		0.2440
E1	0.149		0.1574
e		0.050 BSC	
f	0.0099		0.0196
theta1	0°		8°

24C04_8-LEAD_SOIC.eps

Notes:

1. Complies with JEDEC specification MS-012 dimensions.
2. All linear dimensions in millimeters.

8-LEAD TSSOP (Y)

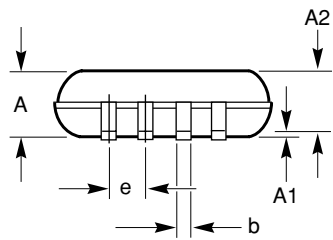
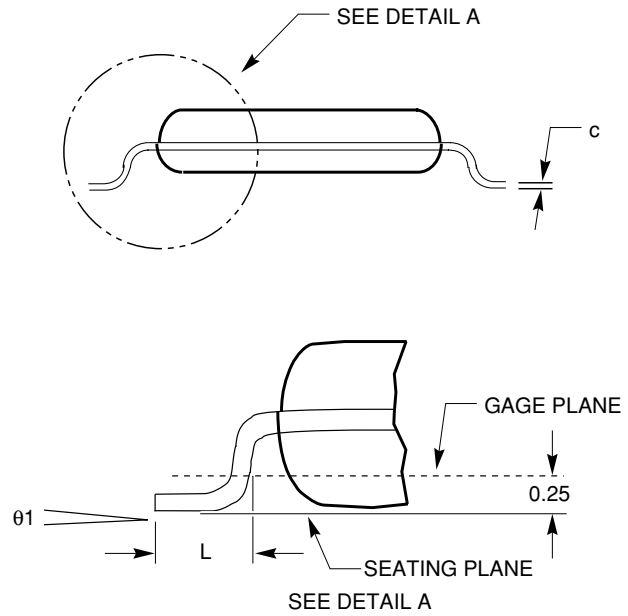
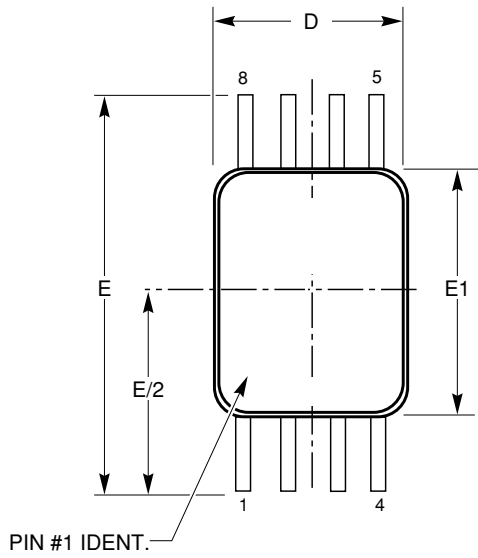

SYMBOL	MIN	NOM	MAX
A			1.20
A1	0.05		0.15
A2	0.80	0.90	1.05
b	0.19		0.30
c	0.09		0.20
D	2.90	3.00	3.10
E	6.30	6.4	6.50
E1	4.30	4.40	4.50
e		0.65 BSC	
L	0.50	0.60	0.75
$\theta 1$	0.00		8.00

Notes:

1. All dimensions in millimeters.

8-PAD TDFN 2X3 PACKAGE (VP2)

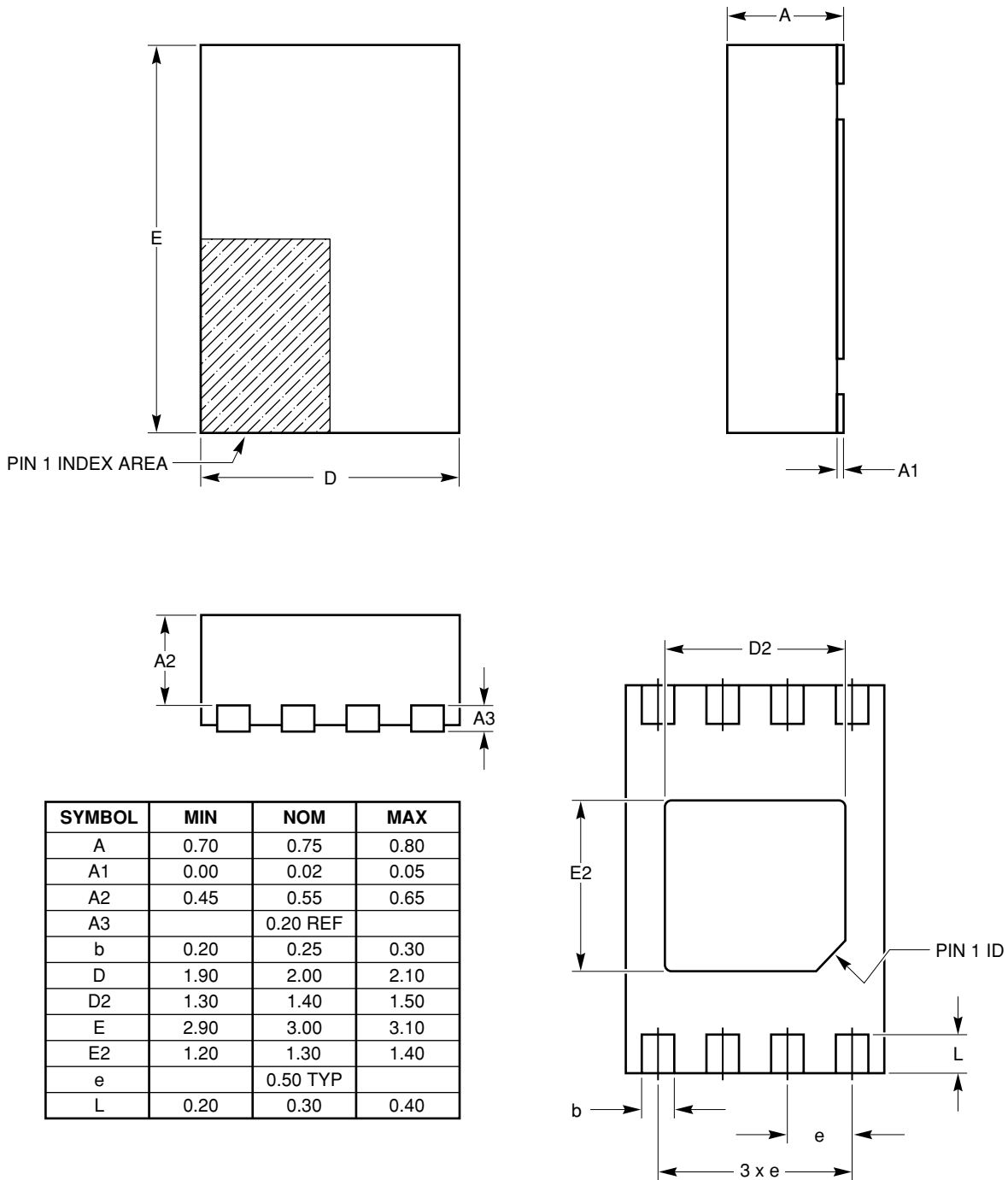

NOTE:

1. ALL DIMENSIONS IN MM. ANGLES IN DEGREES.
2. COPLANARITY APPLIES TO THE EXPOSED PAD AS WELL AS THE TERMINALS. COPLANARITY SHALL NOT EXCEED 0.08 mm.
3. WARPAGE SHALL NOT EXCEED 0.10 mm.
4. PACKAGE LENGTH / PACKAGE WIDTH ARE CONSIDERED AS SPECIAL CHARACTERISTIC.
5. REFER JEDEC MO-229.

TDFN2X3 (03).eps

ORDERING INFORMATION

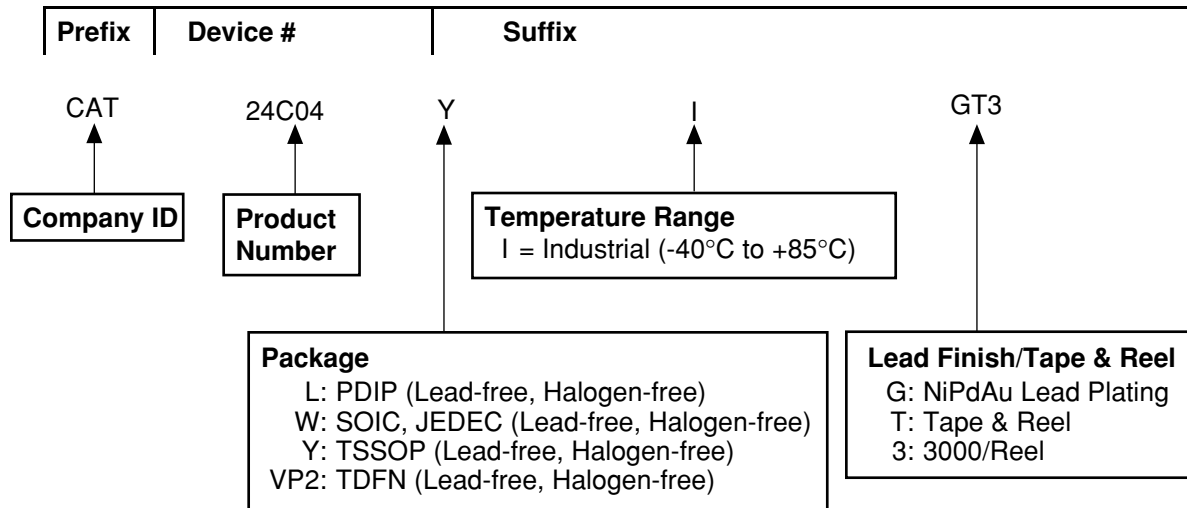

Notes:

- (1) The device used in the above example is a CAT24C04YI-GT3 (TSSOP, Industrial Temperature, 1.8 Volt to 5.5 Volt Operating Voltage, Tape & Reel)

PACKAGE MARKING

8-Lead PDIP

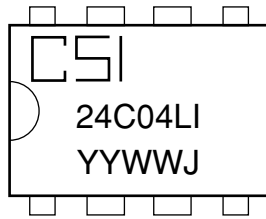

CSI = Catalyst Semiconductor, Inc.
24C04L = Device Code
I = Temperature Range
YY = Production Year
WW = Production Week
J = Product Revision

8-Lead SOIC

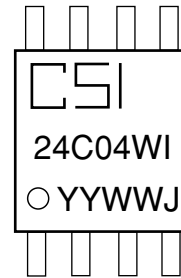

CSI = Catalyst Semiconductor, Inc.
24C04W = Device Code
I = Temperature Range
YY = Production Year
WW = Production Week
J = Product Revision

8-Lead TSSOP

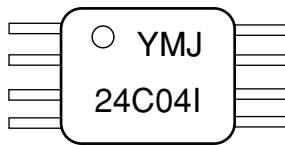

Y = Production Year
M = Production Month
J = Die Revision
24C04 = Device Code
I = Industrial Temperature Range

8-Lead TDFN

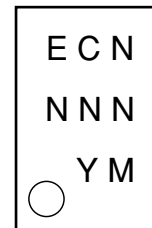

EC = Device Code
N = Traceability Code
Y = Production Year
M = Production Month

Notes:

(1) The circle on the package marking indicates the location of Pin 1.

TAPE AND REEL

Direction of Feed

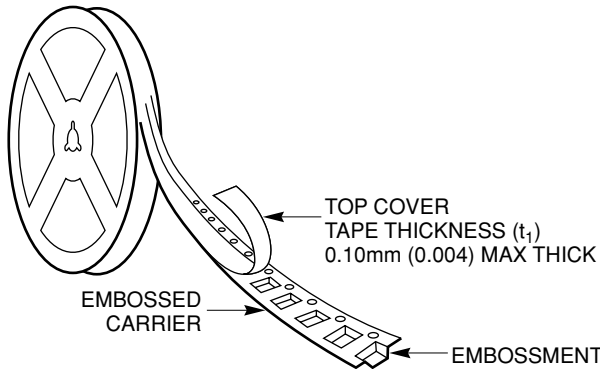

Device Orientation

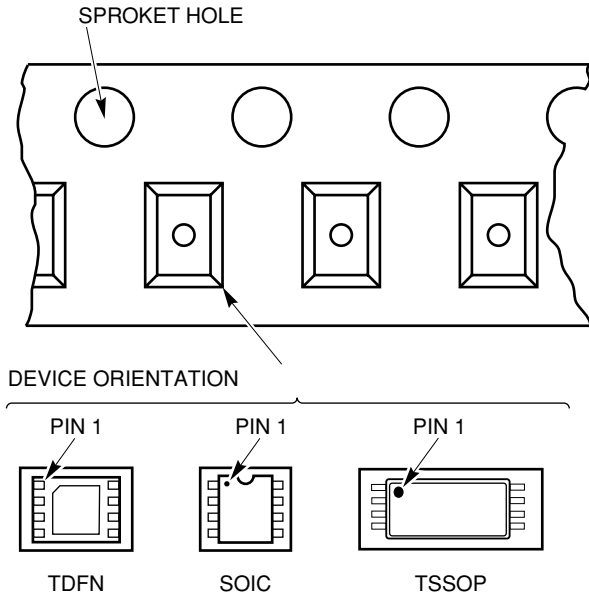

Reel Dimensions⁽¹⁾

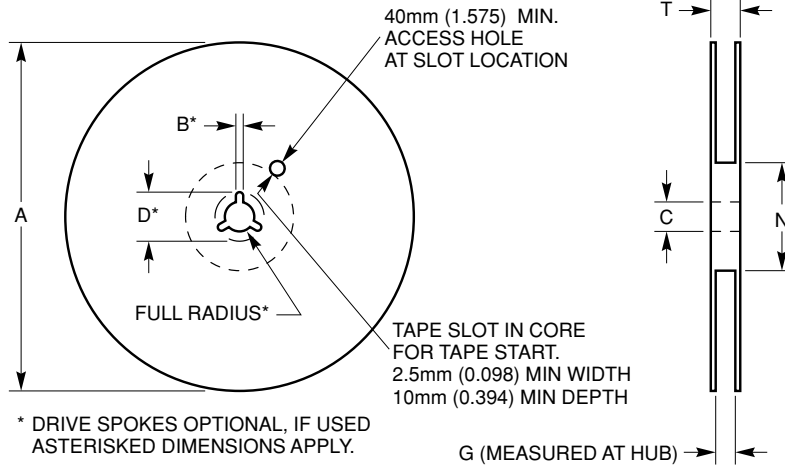

Embossed Carrier Dimensions

Tape Size	A		B Min	C	D* Min	N Min	G	T Max
	Max	Qty/Reel						
8MM	330 (13.00)	3000	1.5 (0.059)	12.80 (0.504) 13.20 (0.5200)	20.2 (0.795)	50 (1.969)	8.4 (0.328)	14.4
12MM							9.9 (1.389)	(0.566)
							12.4 (0.488)	18.4
							14.4 (0.558)	(0.724)

Embossed Carrier Dimensions

Component	Package Type	Tape Size (W)	Part Pitch (P)
8L SOIC	J. S. W. V	12mm	8mm
8L TDFN 2x3mm	SP2, VP2	8mm	4mm

Note:

(1) Metric dimensions will govern; English measurements rounded, for reference only and in parentheses.

Embossed Carrier Dimensions (12 Tape Only)

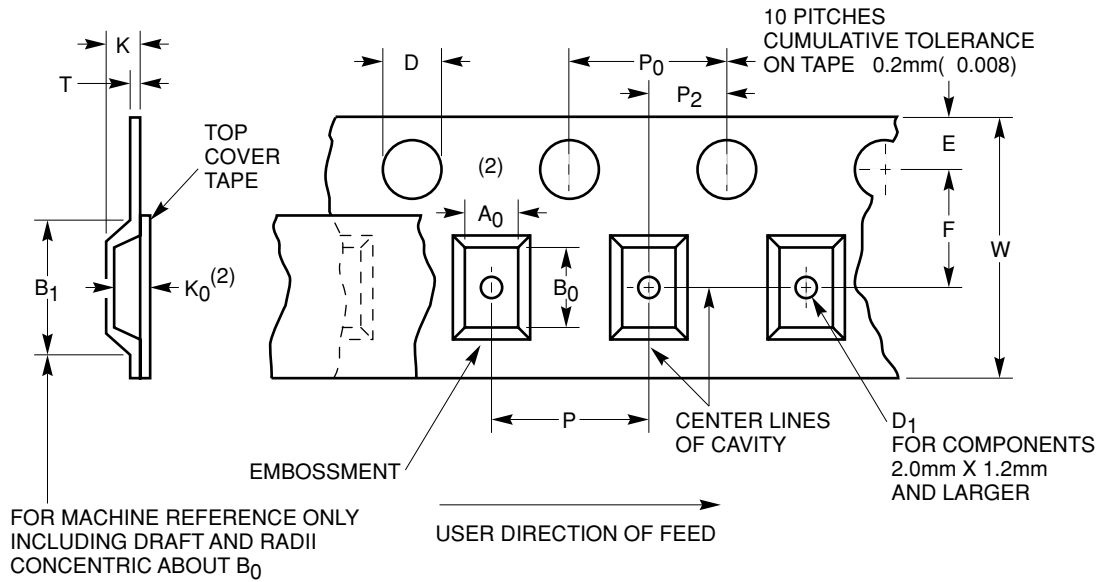

Embossed Tape—Constant Dimensions ⁽¹⁾

Tape Sizes	D	E	P ₀	T Max.	D ₁ Min.	A ₀ B ₀ K ₀ ⁽²⁾
12mm	1.5 (0.059)	1.65 (0.065)	3.9 (0.153)	400 (0.016)	1.5 (0.059)	
	1.6 (0.063)	1.85 (0.073)	4.1 (0.161)			

Embossed Carrier Dimensions (12 Tape Only)

Tape Sizes	B ₁ Max.	F	K Max.	P ₂	R Min.	W	P
12mm	8.2 (0.0323)	5.45 (0.0215)	4.5 (0.177)	1.95 (0.077)	30 (1.181)	11.7 (0.460)	7.9 (0.275)
		5.55 (0.219)		2.05 (0.081)		12.3 (0.484)	8.1 (0.355)

Note:

- (1) Metric dimensions will govern; English measurements rounded, for reference only and in parentheses.
- (2) A₀ B₀ K₀ are determined by component size. The clearance between the component and the cavity must be within 0.05 (0.002) min. to 0.65 (0.026) max. for 12mm tape, 0.05 (0.002) min. to 0.90 (0.035) max. for 16mm tape, and 0.05 (0.002) min. to 1.00 (0.039) max. for 24mm tape and larger. The component cannot rotate more than 20° within the determined cavity, see Component Rotation.

REVISION HISTORY

Date	Revision	Comments
10/07/05	A	Initial Issue
11/10/05	B	Update Ordering Information Add Tape and Reel Specifications

Copyrights, Trademarks and Patents

Trademarks and registered trademarks of Catalyst Semiconductor include each of the following:

DPP™ AE²™ MiniPot™

Catalyst Semiconductor has been issued U.S. and foreign patents and has patent applications pending that protect its products. For a complete list of patents issued to Catalyst Semiconductor contact the Company's corporate office at 408.542.1000.

CATALYST SEMICONDUCTOR MAKES NO WARRANTY, REPRESENTATION OR GUARANTEE, EXPRESS OR IMPLIED, REGARDING THE SUITABILITY OF ITS PRODUCTS FOR ANY PARTICULAR PURPOSE, NOR THAT THE USE OF ITS PRODUCTS WILL NOT INFRINGE ITS INTELLECTUAL PROPERTY RIGHTS OR THE RIGHTS OF THIRD PARTIES WITH RESPECT TO ANY PARTICULAR USE OR APPLICATION AND SPECIFICALLY DISCLAIMS ANY AND ALL LIABILITY ARISING OUT OF ANY SUCH USE OR APPLICATION, INCLUDING BUT NOT LIMITED TO, CONSEQUENTIAL OR INCIDENTAL DAMAGES.

Catalyst Semiconductor products are not designed, intended, or authorized for use as components in systems intended for surgical implant into the body, or other applications intended to support or sustain life, or for any other application in which the failure of the Catalyst Semiconductor product could create a situation where personal injury or death may occur.

Catalyst Semiconductor reserves the right to make changes to or discontinue any product or service described herein without notice. Products with data sheets labeled "Advance Information" or "Preliminary" and other products described herein may not be in production or offered for sale.

Catalyst Semiconductor advises customers to obtain the current version of the relevant product information before placing orders. Circuit diagrams illustrate typical semiconductor applications and may not be complete.



Catalyst Semiconductor, Inc.
Corporate Headquarters
1250 Borregas Avenue
Sunnyvale, CA 94089
Phone: 408.542.1000
Fax: 408.542.1200
www.catalyst-semiconductor.com

Publication #: 1099
Revision: B
Issue date: 11/10/05